

..... **FA1700C**

***Commercial Fire and Burglary
Partitioned Security System
with Scheduling***



Installation and Setup Guide



Table of Contents

.....

List of Figures	vi
Conventions Used in This Manual	vii
SECTION 1: General Description	1-1
About the FA1700C	1-1
Features	1-1
SECTION 2: Partitioning and Panel Linking	2-1
Theory of Partitioning	2-1
Setting-Up a Partitioned System	2-1
Common Lobby Logic	2-1
Master Keypad Setup and Operation	2-3
Panel Linking	2-4
How to Use Panel Linking	2-5
SECTION 3: Installing The Control	3-1
Mounting the Control Cabinet	3-1
Installing the Cabinet Lock	3-1
Grade A Mercantile Premises Listing Guidelines.....	3-1
Grade A Mercantile Safe and Vault Listing Guidelines	3-2
Installing the Control's Circuit Board	3-2
Installing the Keypads.....	3-3
Installing External Sounders	3-4
Auxiliary Relay Connections	3-5
Telephone Line Connections.....	3-7
Wiring Burglary and Panic Devices to Zones 1-8.....	3-8
Installing RPM Devices	3-12
Wireless Zone Expansion.....	3-14
Installing Output Devices.....	3-17
Installing a Remote Keyswitch.....	3-19
Installing a 5140LED Indicator Module	3-19
Installing a Remote Keypad Sounder	3-20
Installing the VA8200 Panel Link Module	3-20
Long Range Radio Connected to the ECP.....	3-21
Long Range Radio Connected to the J2 Triggers	3-23
Installing the Alpha Pager Module	3-23
Access Control Using VistaKey	3-25
Access Control Using the PassPoint Access Control System	3-26
Event Log Connections	3-26
Installing the 4285/4286 VIP Module	3-24
Installing the Audio Alarm Verification Module.....	3-28
Connecting the Transformer	3-31
Earth Ground Connections	3-31
Determining the Control's Power Supply Load.....	3-27
Determining the Size of the Standby Battery	3-33

SECTION 4: Programming	4-1
Program Modes	4-1
Entering and Exiting Programming Mode	4-1
Data Field Programming Mode	4-1
#93 Menu Mode Programming	4-2
Zone Number Designations	4-4
Zone Response Type Definitions.....	4-6
Zone Input Type Definitions	4-7
Programming for Panel Linking.....	4-8
Programming for the Alpha Pager Module.....	4-8
Programming for Access Control.....	4-9
Programming for ECP Long Range Radio	4-10
Programming for the Event Log.....	4-10
SECTION 5: Data Field Descriptions	5-1
About Data Field Programming	5-1
Programming Data Fields	5-1
SECTION 6: Scheduling Options.....	6-1
Time Window Definitions	6-2
Open/Close Schedules Definitions.....	6-3
Scheduling Menu Mode.....	6-4
Time Windows	6-5
Daily Open/Close Schedules	6-5
Holiday Schedules	6-6
Time-Driven Events	6-7
Limitation of Access Schedules	6-11
Temporary Schedules.....	6-12
User Scheduling Menu Mode.....	6-13
SECTION 7: Downloading Primer	7-1
General Information.....	7-1
Unattended Download	7-1
Getting On-Line with a Control Panel.....	7-2
Scheduled Download	7-3
Direct-Wire Downloading	7-4
Telco Handoff.....	7-4
SECTION 8: Setting the Real-Time Clock.....	8-1
General Information.....	8-1
Setting the Time and Date	8-1
SECTION 9: User Access Codes.....	9-1
General Information.....	9-1
User Codes & Levels of Authority	9-1
Multiple Partition Access.....	9-2
Adding a Master, Manager, or Operator Code	9-3
Changing a Master, Manager, or Operator Code.....	9-4
Adding an RF Key to an Existing User.....	9-4
Deleting a Master, Manager, or Operator Code.....	9-4
Exiting the User Edit Mode.....	9-4

SECTION 10: Testing the System.....	10-1
Battery Test	10-1
Dialer Test	10-1
Fire Drill Test (Code + [#] + 69)	10-1
One-Man Fire Walk-Test (Code + [#] + 68)	10-1
Burglary Walk-Test (Code + [5] TEST).....	10-2
Armed Burglary System Test	10-1
Testing Wireless Transmitters	10-1
Trouble Conditions	10-4
To the Installer	10-5
APPENDIX A: Regulatory Agency Statements	A-1
UL Installation Requirements.....	A-1
UL864/NFPA Local Fire	A-1
UL864/NFPA Central Station and Remote Station Fire	A-1
UL609 Grade A Local Mercantile Premises/Local Mercantile Safe & Vault	A-1
UL365 Police Station Connected Burglar Alarm	A-2
UL611/UL1610 Central Station Burglary Alarm	A-2
California State Fire Marshal (CSFM) Requirements.	A-2
APPENDIX B: Summary of System Commands	B-1
APPENDIX C: Specifications	C-1
APPENDIX D: Contact ID and Pager Event Codes	D-1
TABLE OF CONTACT ID EVENT CODES	D-1
Event Log and Pager Alpha Descriptors.....	D-2
Index.....	Index-1
THE LIMITATIONS OF THIS ALARM SYSTEM	
ADEMCO LIMITED WARRANTY	

List of Figures

.....

Figure 3-1: Installing the Lock.....	3-1
Figure 3-2: Cabinet Attack Resistance Considerations	3-2
Figure 3-3: Mounting the PC Board.....	3-2
Figure 3-4: Keypad Connections to Control Panel	3-3
Figure 3-5: Using A Supplementary Power Supply	3-3
Figure 3-6: External Sounder Connections.....	3-5
Figure 3-7: Wiring Auxiliary Relay for Alarm Activation.....	3-6
Figure 3-8: Wiring Auxiliary Relay for Smoke Detector Reset.....	3-6
Figure 3-9: 2-Wire Smoke Detector on Zone 1 (for zone 2 use terminals 17 & 18).....	3-8
Figure 3-10: Wiring 4-Wire Smoke Detectors.....	3-9
Figure 3-11: Wiring a 333PRM to the Control	3-10
Figure 3-12: Wiring a 333PRM using a Power Supply.....	3-10
Figure 3-13: Wiring Latching Glassbreaks to Zone 8.....	3-11
Figure 3-14: Wiring a Normally Closed Sensor Loop for Tamper Supervision.....	3-11
Figure 3-15: Wiring a Normally Open Sensor Loop for Tamper Supervision	3-11
Figure 3-16: Polling Loop Connections to the Control Panel.....	3-13
Figure 3-17: Polling Loop Connections Using One 4297 Extender Module	3-13
Figure 3-18: Polling Loop Connections Using Multiple Extender Modules	3-14
Figure 3-19: Installing the 5881ENHC with Tamper Protection	3-15
Figure 3-20: 5881 RF Receiver (cover removed).....	3-15
Figure 3-21: 4204 Relay Module.....	3-18
Figure 3-22: 4204CF Relay Module.....	3-18
Figure 3-23: Wiring the FSA Module.....	3-18
Figure 3-24: Remote Keyswitch Wiring	3-19
Figure 3-25: Wiring the 5140LED Indicator Module	3-20
Figure 3-26: Remote Keypad Sounder Wiring	3-20
Figure 3-27: Panel Linking Block Diagram.....	3-20
Figure 3-29: Wiring Long Range Radio to Keypad Terminals.....	3-22
Figure 3-30: Wiring the Alpha Pager Module.....	3-24
Figure 3-31: Wiring the VistaKey	3-26
Figure 3-32: Wiring the VISTA Gateway Module	3-26
Figure 3-33: Printer Connections to the 4100SM.....	3-24
Figure 3-34: 4285/4286 VIP Module Connections	3-28
Figure 3-35: AAV Connections	3-28
Figure 3-36: Connecting the Backup Batteries	3-33
Figure 7-1: Direct-Wire Downloading Connections.....	7-4
FA1700C Summary of Connections Diagram.....	D-9

Conventions Used in This Manual



Before you begin using this manual, it is important that you understand the meaning of the following symbols (icons).



These notes include specific information that must be followed if you are installing this system for a UL Listed application.



These notes include information that you should be aware of before continuing with the installation, and that, if not observed, could result in operational difficulties.



This symbol indicates a critical note that could seriously affect the operation of the system, or could cause damage to the system. Please read each warning carefully. This symbol also denotes warnings about physical harm to the user.

ZONE PROG? 1 = YES 0 = NO 0

Many system options are programmed in an interactive mode by responding to alpha keypad display prompts. These prompts are shown in a single-line box.



Additional system options are programmed via data fields, which are indicated by a “star” (T) followed by the data field number.

PRODUCT MODEL NUMBERS:

Unless noted otherwise, references to specific model numbers represent ADEMCO products.

General Description

About the FA1700C

The FA1700C is an 8-partition, UL Listed commercial fire and burglary control panel with the following features:

- Up to 250 zones (hardwired, polling loop, and wireless zones)
- Up to 250 user codes
- Supervision of Notification Appliance Circuits, phone lines, keypads, RF receivers, and output devices
- Scheduling capabilities (allows certain operations to be automated)
- The capability to link up to 8 control panels using Panel Linking Modules

The FA1700C can interface with the following devices:

- Symphony (AUI)
- An alpha numeric paging device (VA8201)
- Panel Link Module (VA8200)
- An ECP Long Range Radio that can send Contact ID messages
- An access control system by using either the ADEMCO PassPoint system (via the VISTA Gateway Module) or a VistaKey module (via the polling loop)

UL The access control function is not Listed for use with the FA1700C Control Panel in a UL installation.

 The system supports either the VistaKey or the VISTA Gateway Module, not both.

Features

Hardwire and Optional Expansion Zones

- Provides 8 hardwire zones.
- Supports up to 16 2-wire smoke detectors each on zone 1 and zone 2 (32 total).
- Automatically resets 4-wire smoke detectors using the J2 output when a code + off is entered.
- Triggers the built-in sounders on other hardwired smoke detectors if one smoke detector annunciates an alarm. This feature requires a 4204 Relay Module and/or the 333PRM.
- Provides tamper supervision on the hardwire zones.
- Supports up to 50 2-wire latching glassbreak detectors on zone 8.
- Supports up to 242 additional expansion zones using a built-in polling (multiplex) loop.
- Supports up to 250 wireless zones, fewer if using hardwire and/or polling loop zones.

UL The 5881ENHC RF Receiver and the 5869 Holdup Switch Transmitter are listed for UL Commercial Burglary applications. All other RF receivers and transmitters are not listed for UL Commercial Burglary applications.

- Can program burglary zones as silent in the alarm condition (alarm output is silent and the keypad does not display or sound the alarm).
- Provides three keypad panic keys: 1 + * (A), * + # (B), and 3 + # (C).

Peripherals Devices

- Supports up to 31 addressable devices, (keypads, RF receivers, relay modules, etc.).

- Supervises devices (keypads, RF receivers, and relay modules) and individual relays (up to 32), as well as system zones (RF receivers and keypad panics).
 - Provides 96 outputs using 4204 and 4204CF Relay Modules, Fire System Annunciators (FSA-8, FSA-24), and V-Plex Relay Modules can activate outputs in response to system events (alarm condition), at a specific time of day, at random times, and manually using the #70 Relay Command Mode.
 - Supports additional style-Y supervised Notification Appliance Circuits using a 4204CF.
 - Supports the ADEMCO 4285/4286 VIP Module, which allows access to the system from either a remote location or on the premises
-

UL The 4285/4286 VIP Module is not Listed for use with the FA1700C Control Panel in a UL installation.

- Supports the ADEMCO 4146 Keyswitch on any one of the system's 8 partitions.
- Supports the PS24 Power Supply Module, which supplies two 24VFW, 1.7A full-wave rectified, unfiltered outputs.

Arming/Disarming and Bypassing

- Can arm the system with zones faulted (Vent Zone). These zones are automatically bypassed and can be programmed to automatically unbypass when the zone restores.
 - Can arm with entry/exit and interior type zones faulted (Arm w/Fault). These zones must be restored before the exit delay expires, otherwise an alarm is generated.
-

UL

- Vent zones cannot be used in UL installations.
- You **must disable** the Force Arm option (used in conjunction with the Arm w/Fault option), in UL installations.

- Provides global arming capability (ability to arm all partitions the user code has access to in one command).
- Can Quick Exit an armed premises without having to disarm and then rearm the system.
- Can be armed in one of three STAY modes or Instant modes, automatically bypassing specific burglary zones regardless of the zone response type.
- Can automatically bypass specific zones if no one exits the premises after arming (Auto-STAY). Auto-STAY will not occur if the system is armed via an RF transmitter, VIP module, scheduling, access control, keyswitch, or downloading.
- Can bypass a group of zones with one set of keystrokes.
- Supports Exit Error Logic, whereby the system can tell the difference between a regular alarm and an alarm caused by leaving an entry/exit door open. If the system is not subsequently disarmed, faulted entry/exit zone(s) and/or interior zones are bypassed and the system arms.
- Supports Recent Close report, which is designed to notify the central station that an alarm has occurred within 2 minutes after the exit delay has expired.

Partitioning and Panel Linking

- Can control 8 separate areas (partitions) independently, each functioning as if it had its own separate control. All fire zones must be assigned to partition 1.
- Provides a Common Lobby partition, which can be programmed to arm automatically when the last partition is armed, and to disarm when the first partition is disarmed.
- Provides a Master partition (9), used for the purpose of viewing the status of all partitions at the same time.
- Can display fire, burglary, panic, and trouble conditions at all other partitions' keypads (selectable option).
- Can "link" together up to 8 control panels. This allows users to access and control from a keypad another control panel.

Scheduling

- Can automate system functions, such as arming, disarming, and activation of outputs (e.g., lights).
- Provides access schedules (for limiting system access to users by time).
- Provides an End User Output Programming Mode, allowing the user to control outputs.

Access Control

- Supports up to 15 VistaKey modules (15 access points), which are used for access control. It is a single-door access control module.
 - Support up to 500 access cards.
-

- Supports ADEMCO PassPoint system via one VISTA Gateway Module (VGM), for a fully integrated access control system.
- Can store access control events in the event log.

System Communication

- Provides supervision of the phone lines (main and backup)
- Supports the 5140DLM optional backup dialer for the second phone line.
- Supports ADEMCO Contact ID; ADEMCO High Speed; ADEMCO Express; and 3+1, 4+1, and 4+2 ADEMCO and Sescoa/Radionics Low-Speed formats.



The system is shipped defaulted for Contact ID communication. It is the only format capable of uniquely reporting all 250 zones, as well as openings and closings for all 250 users. This requires central stations to be equipped with the ADEMCO 685 receiver using software level 4.10 or higher to fully support all new FA1700C report codes. If you need to update your 685 receiver, contact your distributor.

- Can send messages such as alarms, opens/closes, etc. to up to 8 paging services.
- Provides two paging formats (alphanumeric – requires the VA8201 Alpha Pager Module; and numeric – sent directly by the control)
- Supports Dynamic Signaling feature, which prevents redundant signals being sent to the central station when both the built-in dialer and Long Range Radio are used.
- Provides an Audio Alarm Verification (AAV) option that permits voice dialog between an operator at the central station and a person at the premises. An AAV unit, such as Eagle model 1250, is required.



The Eagle Model 1250 AAV unit is not UL Listed.

Downloading

- Supports upload and download capability.
- Can perform unattended downloading (no one at the downloading computer).
- Provides an Installer Unattended Program Mode. This allows the installer to program the download phone number, subscriber number, and primary central station receiver phone number without entering the normal program mode.
- Can periodically and automatically perform a scheduled download.



Unattended and Scheduled Downloading are not UL Listed features.

- Can download access control cardholder information.

Event Log

- Provides an event log (history log) that can store up to 1000 events.
- Can print the event log on a serial printer or parallel printer using the VA8201 Alpha Pager Module.
- Can view the event log on an alpha keypad or AUI.

Fire Walk-Test Mode

- Provides an automatic test of integrated V-Plex devices that have the automatic test feature.
- Can display all fire zones that remain untested.
- Can log test results in the event log.
- Can report the test results to the central station.

Additional Features

- Provides two style-Y supervised Notification Appliance Circuits.
- Provides an auxiliary relay (form C) that can activate alarms troubles/supervisories, reset 4-wire smoke detectors, or as a battery saver (removes power from non-critical loads 4 hours after AC power loss).
- Provides up to 60 installer-defined, custom words that can be used for zone descriptors.

- Provides 35 keypad macro commands (each macro is a series of keypad commands of up to 32 keystrokes) using the A, B, C, and D keys by partition.
- Provides cross-zone capability, which helps prevent false alarms by preventing a zone from going into alarm unless its cross-zone is also faulted within a 5-minute period.
- Contains a built-in User's Manual, which provides the end user with a brief explanation of the function of a key when the user presses any of the function keys on the keypad for 5 seconds.
- Provides trigger outputs, which may interface with Long Range Radio equipment or other devices such as keyswitch LEDs, or printer.
- Provides an option to have trouble and supervisory conditions to automatically clear from the display when the zone returns to the ready/normal state (entry of Code + OFF is not required).
- Provides Maintenance Signal support for certain smoke detectors (5808, 4192CPM, 4192SDM, 4192SDTM, 5192).



At least one 2-line alpha keypad (FA560KP) must be connected to the system for programming (if you are using keypad programming), and must remain connected to the system in order to allow the primary user to program additional user codes into the system at a later time.

Partitioning and Panel Linking

Theory of Partitioning

This system provides the ability to arm and disarm up to 8 different areas, as if each had its own control. These areas are called partitions. A Partitioned system allows the user to disarm certain areas while leaving other areas armed, or to limit access to certain areas to specific individuals. Each system user can be assigned to operate any or all partitions, and can be given a different authority level in each.

Before anything can be assigned to those partitions, you must first determine how many partitions (1-8) are required. Following are some facts you need to know about partitioning.

Keypads

Each keypad must be given a unique "address" and be assigned to one partition. It can also be assigned to Partition 9 if Master keypad operation is desired. (See "Master Keypad Setup and Operation" later in this section.)

Zones

Each zone must be assigned to one partition. The zones assigned to a partition will be displayed on that partition's keypad(s).



All fire zones must be assigned to partition 1 to insure that all Fire Test modes operate correctly.

Users

Each user may be given access to one or more partitions. If a user is to operate more than one partition and would like to arm/disarm all or some of those partitions with a single command, the user must be enabled for Global Arming for those partitions (when entering user codes).

A user with access to more than one partition (multiple access) can "log on" to one partition from another partition's keypad, provided that program field 2*18: Enable GOTO is enabled for each partition he/she wants to log on to from another.

A partition can be selected as a "common lobby" partition, and other partitions can affect this partition by causing arming/disarming of this partition to be automated (see "Common Lobby Logic" later in this section).

Setting-Up a Partitioned System

The basic steps to setting up a partitioned system are described below. If you need more information on how to program the options, see *SECTION 4: Programming*.

1. Determine how many partitions the system will consist of (programmed in field 2*00).
2. Assign keypads to partitions (*Device Programming* in the #93 Menu Mode).
3. Assign zones to partitions (*Zone Programming* in the #93 Menu Mode).
4. Confirm zones are displayed at the keypad(s) assigned to those partitions.
5. Assign users to partitions.
6. Enable the GOTO feature (program field 2*18) for each partition a multiple-access user can log on to (alpha keypad only).
7. Program partition-specific fields (see the *SECTION 5: Data Field Descriptions*).

Common Lobby Logic

When an installation consists of a partition shared by users of other partitions in a building, that shared partition may be assigned as the "common lobby" partition for the system (program field 1*17). An example of this might be in a medical building where there are two doctors' offices and a common entrance area (see example that follows explanation).

The Common Lobby feature employs logic for automatic arming and disarming of the common lobby. Two programming fields determine the way the common lobby will react relative to the status of other partitions. They are: 1*18 Affects Lobby and 1*19 Arms Lobby.

1*18 Affects Lobby (must be programmed by partition)

Setting this field to 1 for a specific partition causes that partition to affect the operation of the common lobby as follows:

- a. When the first partition that affects the lobby is disarmed, the lobby is automatically disarmed.
- b. The common lobby cannot be armed unless every partition selected to affect the lobby is armed.

1*19 Arms Lobby (must be programmed by partition)

Setting this field to 1 for a specific partition causes that partition to affect the operation of the common lobby as follows:

- a. The common lobby cannot be armed unless every partition selected to affect the lobby is armed.
- b. Arming a partition that is programmed to arm the lobby causes the system to automatically attempt to arm the lobby. If any faults exist in the lobby partition, or if another partition that affects the lobby is disarmed, the lobby cannot be armed, and the message "UNABLE TO ARM LOBBY PARTITION" is displayed.



You cannot select a partition to "arm" the lobby unless it has first been selected to "affect" the lobby. Do not enable field 1*19 without enabling field 1*18.

The following chart sums up how the common lobby partition will operate.

1*18 Affects Lobby	1*19 Arms Lobby	Disarms when partition disarms?	Attempts to arm when partition arms?	Can be armed if other partitions disarmed?
0	0	NO	NO	YES
1	0	YES	NO	NO
1	1	YES	YES	NO
0	1	---ENTRY NOT ALLOWED---		

Example

Here is an example of how the lobby would react in a typical setup.

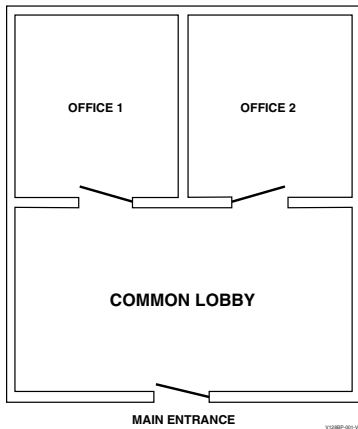

User #1 has access to Office #1 and the Common Lobby.
 User #2 has access to Office #2 and the Common Lobby.
 Office #1 is set up to affect the Common Lobby, but not arm it.
 Office #2 is set up to affect and arm the Common Lobby.
NOTE: In the tables below, the notations in parentheses () indicate the current status of the other partition when the user takes action.

Sequence #1:

	Office 1	Office 2	Lobby Action
User #1:	Disarms	(Armed)	Disarms
User #2:	(Disarmed)	Disarms	No Change
User #1:	Arms	(Disarmed)	No change
User #2:	(Armed)	Arms	Arms

Sequence #2:

	Office 1	Office 2	Lobby Action
User #2:	(Armed)	Disarms	Disarms
User #1:	Disarms	(Disarmed)	(No change)
User #2:	(Disarmed)	Arms	No Change
User #1:	Arms	(Armed)	No Change

Notice that in sequence #1, because Office #2 was the last to arm, the lobby also armed (Office #2 is programmed to affect and arm the lobby). In sequence #2, the lobby could not arm when Office #2 armed, because Office #1, which affects the lobby, was still disarmed.

When Office #1 armed, the lobby still did not arm because Office #1 was not programmed to arm the lobby. User #1 would have to arm the lobby manually. Therefore, you would want to program a partition to affect and arm the lobby if the users of that partition are expected to be the last to leave the building.



Do not assign partition 1 as the common lobby if fire zones are being used in the system. All fire zones must be assigned to partition 1 to ensure all Fire Test modes operate correctly.

How User Access Codes Affect the Common Lobby

Codes with Global Arming

If a code is given "global arming" when it is defined (see the *SECTION 9: User Access Codes*), the keypad prompts the user to select the partitions they want to arm. Only the partitions the user has access to are displayed. This allows the user to choose the partitions to be armed or disarmed, and so eliminates the "automatic" operation of the lobby. Keep in mind, however, that if a user attempts to arm all, and another "affecting" partition is disarmed, the user cannot arm the lobby, and the message "UNABLE TO ARM LOBBY PARTITION" is displayed.

Codes with Non-Global Arming

If a user arms with a non-global code, the lobby partition operation is automatic, as described by fields 1*18 and 1*19.

Other Methods of Arming/Disarming

Common Lobby logic remains active when arming or disarming a partition that affects and/or arms the common lobby in one of the following manners:

- Quick-Arm
- Keyswitch
- Wireless Button
- Wireless Keypad

Arming/Disarming Remotely

If a user arms or disarms remotely (through Compass downloading software), the lobby does not automatically follow another partition that is programmed to arm or disarm the lobby. The lobby must be armed separately, after arming all affecting partitions first.

Auto-Arming/Disarming

If scheduling is used to automatically arm and/or disarm partitions, the common lobby partition does not automatically follow another partition that is programmed to arm or disarm the lobby. The lobby partition must be scheduled to arm/disarm and must be scheduled as the last partition to arm.



If you are using auto-arming, make sure that the **Auto-Arm Delay** and **Auto-Arm Warning** periods, for the lobby partition, (fields 2*05 and 2*06) combined are longer than that of any other partition that affects the lobby. This causes the lobby to arm last.

Master Keypad Setup and Operation

Although this system has eight actual partitions, it provides an extra partition strictly for the purpose of assigning keypads as Master keypads for the system.

Assigning any keypad to Partition 9 in *Device Programming* in the #93 Menu Mode makes that keypad a Master keypad. A Master keypad reflects the status of the entire system (Partitions 1-8) on its display at one time. This is useful because it eliminates the need for a building security officer to have to log on to various partitions from one partition's keypad to find out where an alarm has occurred.

The following is a typical display:

```
SYSTEM 12345678
STATUS RRNNA *B
```

Possible status indications include:

A = Armed Away **S** = Armed Stay **M** = Armed Maximum **C** = Comm Fail
I = Armed Instant **R** = Ready **N** = Not Ready
B = Bypassed/Ready ***** = Alarm **T** = Trouble
F = Fire Alarm **P** = AC Power Failure **L** = Low System Battery

To obtain more information regarding a particular partition, enter [*] + Partition No. (e.g., [*] + [4]). This allows viewing only of that partition. In order to affect that partition, the user must use a code that has access to that partition. Also, in order for a user of any partition to log on to Partition 9 to view the status of all partitions, that user must have access to all partitions. Otherwise, access is denied.

The following is displayed for a fault condition on Zone 2 (Loading Dock Window) on Partition 1 (Warehouse) when a user logs on from a keypad on Partition 9:

```
WHSE DISARMED
HIT * FOR FAULTS
```

Pressing [*] causes the following display to appear at Partition 1's keypad(s):

```
FAULT 002 LOADING
DOCK WINDOW
```

Additional zone faults are displayed one at a time. To display a new partition's status, press [*] + Partition No.

The Armed LED on a Master keypad is lit only if all partitions have been armed successfully. The Ready LED is lit only if all partitions are "ready to arm." Neither LED is lit if only some partitions are armed and/or only some partitions are ready.

Press [*] + [0] or [*] + [9] to return to the master partition. Otherwise, if no keys are pressed for 2 minutes, the system automatically returns to the master partition.

The sounder on a Master keypad reflects the sound of the most critical condition on all of the partitions. The priority of the sounds, from most to least critical, is as follows:

1. Pulsing fire alarm sounds
2. Steady burglar alarm sounds
3. Trouble sounds (rapid beeping)

Silence the sounder by pressing any key on the Master keypad or a keypad on the partition where the condition exists.



A Master keypad uses the same panics as Partition 1. Master keypad panics are sent to Partition 1, and will activate on Partition 1. Therefore, panics must be programmed for Partition 1.

Panel Linking

Up to eight FA1700C control panels may be networked, enabling a user to control the features of all control panels from a single location. The panel linking bus supports an end-to-end network length of up to 4,000 feet, making it ideal for multi-building environments (e.g., a shopping mall, college campus, etc.).

UL Panel Linking is not permitted in UL installations.

Panel linking requires a VA8200 Panel Link Module (PLM) on each FA1700C. Users can link (access other control panels) in any of three different modes: Single-Partition, Single-Panel Mode, Multi-Partition, Multi-Panel Mode, Multi-Panel View Mode. These modes are described later in this section.

Each PLM connects to the ECP bus on the control panel and communicates to each PLM via an RS-485 bus (3-wire twisted cable run) with a maximum wire-run of 4000 feet end-to-end.



- Users 001-050 are the only users that can perform panel linking and are automatically assigned panel linking access when added to the system.
- An alpha keypad must be used for panel linking.
- The system may take up to 7 seconds to respond to a command when in a panel linking mode

NOTE: A user cannot access partitions or panels that they have not been assigned to.

Panel Link Module Supervision

The Panel Link Module can be supervised for its connection to the control panel. This module’s supervisory zone is 8xx, where “xx” = the ECP address of the PLM. You must program that zone with response type 05 (Day/Night) in *Zone Programming* in the #93 Menu Mode (refer to the *Programming Guide* for detailed programming instructions). If you want to report the supervisory failure to the central station and/or to a paging service, the appropriate reporting parameters for that zone must be programmed.

If you want the supervisory failure of other PLM(s) on other linked control panels to display on this control panel, they must be programmed into *Zone Programming* in the #93 Menu Mode with response type 14 in this control panel (refer to the *Programming Guide* for detailed programming instructions). The panel ID number for each module must match the panel ID number programmed in *Device Programming* of its “host” FA1700C.

How to Use Panel Linking

Panel Linking can be used in any of three different modes:

- Single-Partition, Single-Panel – displays status of a partition on a remote control panel and allows control of that remote control panel.
- Multi-Partition, Multi-Panel Mode – displays status and allows arming/disarming of multiple partitions at once on a remote control panel.
- Multi-Panel View Mode – displays status and allows arming/disarming of multiple remote control panels at a time.

NOTE: A user will not be able to access or view partitions or panels that they have not been assigned to.

Single-Partition Single-Panel Mode

To access the Single-Partition, Single Panel mode, perform the following steps:

Step	Action
1	Enter User Code (for users 001-050) + [#] + [86] .
2	Enter the panel ID number (01-08) of the panel you want to link to.
3	Enter the partition number of the panel. The keypad displays “AWAITING PANEL LINK.” After a few seconds, the keypad displays the status of the partition along with the panel ID number and partition number flashing in the upper right-hand corner. The user now has full control of the remote control panel. All functions can be performed except the following: <ul style="list-style-type: none"> • Those limited by the user’s authority level. • The user cannot enter Installer Program mode • The user cannot execute another panel linking mode. NOTE: To execute another panel linking mode or to access a different remote panel, the user must first exit this mode (return to the original control panel).
4	To exit, enter the User Code (for users 001-050) + [#] + [85] . After a few seconds, the keypad displays the status of the original partition for the keypad.

Multi-Partition Multi-Panel Mode

To perform a function in the Multi-Partition, Multi Panel mode, follow the steps below:

Step	Action																																	
1	<p>Enter User Code (for users 001-050) + [#] + [88].</p> <p>The keypad displays the following:</p> <table border="1" data-bbox="337 346 712 415"> <tr> <td>PANELnn</td> <td>1</td> <td>2</td> <td>3</td> <td>4</td> <td>5</td> <td>6</td> <td>7</td> <td>8</td> </tr> <tr> <td>STATUS</td> <td>x</td> <td>x</td> <td>x</td> <td>x</td> <td>x</td> <td>x</td> <td>x</td> <td>x</td> </tr> </table> <p>where “nn” = panel ID number (01-08), “12345678” are the partition numbers and “xxxxxxxx” is the status of each partition of that panel. Status indications include:</p> <table data-bbox="261 485 1143 651"> <tr> <td>A = Armed Away</td> <td>S = Armed Stay</td> <td>M = Armed Maximum</td> </tr> <tr> <td>I = Armed Instant</td> <td>R = Ready</td> <td>N =Not Ready</td> </tr> <tr> <td>B = Bypassed/Ready</td> <td>* = Alarm</td> <td>T = Trouble</td> </tr> <tr> <td>F = Fire Alarm</td> <td>P = AC Power Failure</td> <td>L = Low System Battery</td> </tr> <tr> <td>C = Comm Fail</td> <td></td> <td></td> </tr> </table> <p>NOTES: See table later in this section for priority of displays. A “•” under a partition number indicates the user does NOT have access to that partition.</p>	PANELnn	1	2	3	4	5	6	7	8	STATUS	x	x	x	x	x	x	x	x	A = Armed Away	S = Armed Stay	M = Armed Maximum	I = Armed Instant	R = Ready	N =Not Ready	B = Bypassed/Ready	* = Alarm	T = Trouble	F = Fire Alarm	P = AC Power Failure	L = Low System Battery	C = Comm Fail		
PANELnn	1	2	3	4	5	6	7	8																										
STATUS	x	x	x	x	x	x	x	x																										
A = Armed Away	S = Armed Stay	M = Armed Maximum																																
I = Armed Instant	R = Ready	N =Not Ready																																
B = Bypassed/Ready	* = Alarm	T = Trouble																																
F = Fire Alarm	P = AC Power Failure	L = Low System Battery																																
C = Comm Fail																																		
2	<p>The following functions can be performed:</p> <p>Press [1] to attempt to disarm all partitions.</p> <p>Press [2] to attempt to arm AWAY all partitions.</p> <p>Press [3] to attempt to arm STAY all partitions.</p> <p>Press [4] to attempt to arm MAXIMUM all partitions.</p> <p>Press [7] to attempt to arm INSTANT all partitions.</p> <p>Press [*] to read the status of the next panel.</p> <p>Press [#] key to read the status of the previous panel.</p> <p>Press [0] to exit mode. After a few seconds, the keypad displays the status of the original partition of the original panel for the keypad. Also, this mode will end in approximately 120 seconds if no keys are pressed.</p> <p>NOTES:</p> <p>When performing any of the arming commands, if there are faults in any of the partitions, none of the partitions will arm. These faults must be corrected or bypassed before attempting to arm.</p> <p>When performing either a STAY or INSTANT arm command, the system always arms in mode 1 (see the <i>FA1700C User Guide</i> for a detailed explanation of the STAY and INSTANT arming modes).</p> <p>The user cannot execute another panel linking mode. To execute another panel linking mode or to access a different remote panel, the user must first exit this mode (return to the original control panel).</p>																																	

Multi-Panel View Mode

To perform a function in the Multi-Panel View mode, follow the steps below:

Step	Action															
1	<p>Enter User Code (for users 001-050) + [#] + [87]. The keypad displays the following typical display:</p> <div style="border: 1px solid black; padding: 5px; width: fit-content; margin: 10px auto;"> <pre>ALLPANEL 1 2 3 4 5 6 7 8 STATUS x x x x x x x x</pre> </div> <p>where “12345678” are the panel ID numbers and “xxxxxxx” is the overall status of each panel. Status indications include:</p> <table style="width: 100%; border: none;"> <tr> <td>A = Armed Away</td> <td>S = Armed Stay</td> <td>M = Armed Maximum</td> </tr> <tr> <td>I = Armed Instant</td> <td>R = Ready</td> <td>N = Not Ready</td> </tr> <tr> <td>B = Bypassed/Ready</td> <td>* = Alarm</td> <td>T = Trouble</td> </tr> <tr> <td>F = Fire Alarm</td> <td>P = AC Power Failure</td> <td>L = Low System Battery</td> </tr> <tr> <td>C = Comm Fail</td> <td></td> <td></td> </tr> </table> <p>NOTE: See table later in this section for priority of displays.</p>	A = Armed Away	S = Armed Stay	M = Armed Maximum	I = Armed Instant	R = Ready	N = Not Ready	B = Bypassed/Ready	* = Alarm	T = Trouble	F = Fire Alarm	P = AC Power Failure	L = Low System Battery	C = Comm Fail		
A = Armed Away	S = Armed Stay	M = Armed Maximum														
I = Armed Instant	R = Ready	N = Not Ready														
B = Bypassed/Ready	* = Alarm	T = Trouble														
F = Fire Alarm	P = AC Power Failure	L = Low System Battery														
C = Comm Fail																
2	<p>The following functions can be performed::</p> <p>Press [1] to attempt to disarm all partitions on all panels. Press [2] to attempt to arm AWAY all partitions on all panels. Press [3] to attempt to arm STAY all partitions on all panels. Press [4] to attempt to arm MAXIMUM all partitions. Press [7] to attempt to arm INSTANT all partitions. Press [0] to exit mode. After a few seconds, the keypad displays the status of the original partition of the original panel for the keypad. Also, this mode will end in approximately 120 seconds if no keys are pressed.</p> <p>NOTES:</p> <p>When performing any of the arming commands, if there are faults in any of the partitions of a panel, the system will not arm that panel, but will arm all the other partitions of the other panels.</p> <p>When performing either a STAY or INSTANT arm command the system always arms in mode 1.</p> <p>The user cannot execute another panel linking mode. In order to perform another panel linking mode or to access a different remote panel, the user must first exit this mode (return to the original control panel).</p>															

Priority of Displays for Multi-Partition and Multi-Panel Modes

This table shows the priority of displays if more than one of these conditions exists at the same time.

Priority	Description	Display
1	Fire Alarm	F
2	All Other Alarms	*
3	AC Loss	P
4	Comm Fail	C
5	System Low Battery	L
6	Trouble	T
7	Bypass	B

Priority	Description	Display
8	Not Ready	N
9	Ready	R
10	Armed STAY	S
11	Armed AWAY	A
12	Armed INSTANT	I
13	Armed MAXIMUM	M

Installing The Control

This section describes the procedures for mounting and wiring the control panel and all the peripheral devices.

Mounting the Control Cabinet

To mount the control cabinet, perform the following steps:

Step	Action
1	Before mounting the circuit board, remove the metal knockouts for the wiring entry that you will be using. DO NOT ATTEMPT TO REMOVE THE KNOCKOUTS AFTER THE CIRCUIT BOARD HAS BEEN INSTALLED.
2	Using fasteners or anchors (not supplied), mount the control cabinet to a sturdy wall in a clean, dry area that is not readily accessible to the general public. The back of the cabinet has 4 holes for this purpose.

UL To provide certificated burglary service for UL installations, refer to the special requirements and *Figure 3-2 Cabinet Attack Resistance Considerations* to follow.

Installing the Cabinet Lock

To install the lock, perform the following steps:

Step	Action
1	Remove cabinet door, then remove the lock knockout from the door. Insert the key into the lock.
2	Position the lock in the hole, making certain that the latch will make contact with the latch bracket when the door is closed.
3	When correctly positioned, push the lock until it is held securely by its snap tabs.

Use an Ademco No. K4445 Lock (supplied).

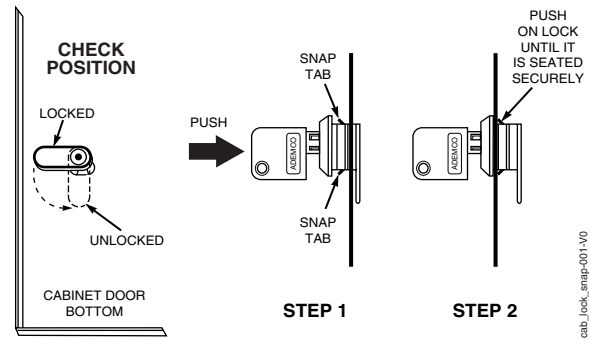

Figure 3-1: Installing the Lock

Grade A Mercantile Premises Listing Guidelines

- The panel door must be supervised. Mount the clip-on tamper switch (supplied) to the cabinet's right side wall as shown in the diagram below, and wire it to zone 6.
- Use a bell with a tamper-protected housing such as the ADEMCO AB12. The bell housing's tamper switch and inner tamper linings must also be wired to zone 6.
- Assign zone 6 to a burglary partition. Program it for day trouble/night alarm (zone type 5) when only one burglary partition is used. Program it for 24-hr. audible alarm (zone type 7) when more than one burglary partition is used.
- All wiring between the bell and panel must be run in conduit. Remaining wires do not need to be run in conduit.
- All wiring that is not run in conduit must exit from the knockout openings on the bottom or back of the cabinet.
- All unused knockouts must be plugged using the disc plugs and carriage bolts (supplied), as indicated in the diagram below.
- Fasten the cabinet door to the cabinet backbox using the 18 one-inch-long Phillips-head screws (supplied) after all wiring, programming, and checkout procedures have been completed.

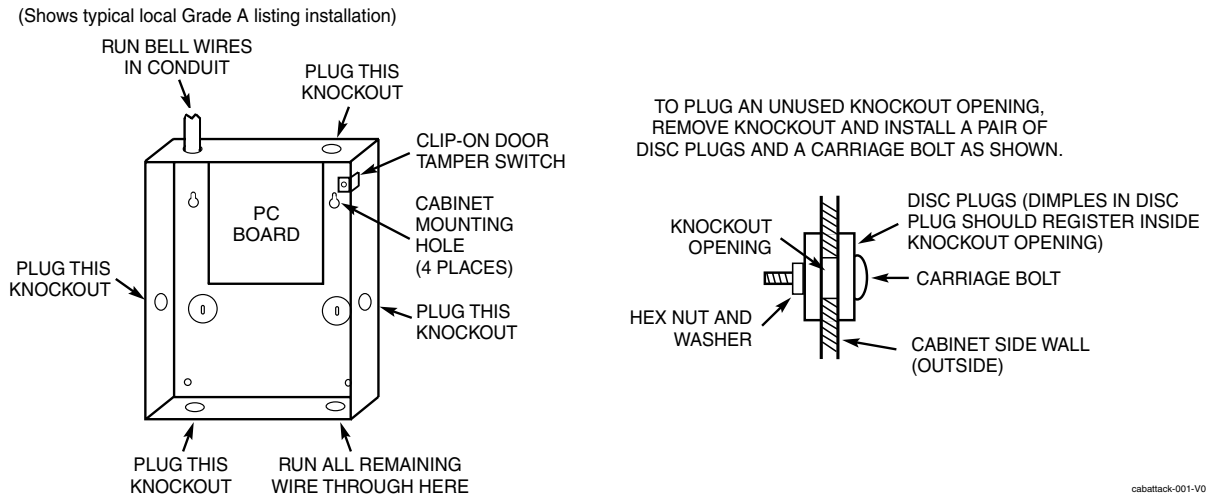

Figure 3-2: Cabinet Attack Resistance Considerations

Grade A Mercantile Safe and Vault Listing Guidelines

- Follow the guidelines given above for Grade A Mercantile Premises listing.
- Mount a shock sensor such as Sentrol No. 5402 to the control's backbox. Follow the manufacturer's instructions for proper sensor mounting. This sensor also must be wired to zone 6.
- For safe and vault applications, a UL Listed contact must be used inside the cabinet through one of the knockouts for pry-off tamper purposes. This sensor also must be wired to zone 6.

Installing the Control's Circuit Board

To install the circuit board in the cabinet, perform the following steps:

Step	Action
1	Hang the three mounting clips on the raised cabinet tabs. Refer to <i>Figure 3-3</i> (Detail B). Make sure the clip orientation is exactly as shown in the diagram to avoid damage. This will also avoid problems with insertion and removal of the PC board.
2	Insert the top of the circuit board into the slots at the top of the cabinet. Make certain that the board rests in the slots as indicated (Detail A).
3	Swing the base of the board into the mounting clips and secure the board to the cabinet with the accompanying screws.

Notes:

- Make certain that the mounting screws are tight. This ensures that there is a good ground connection between the PC board and the cabinet.
- Dress field wiring away from the microprocessor (center) section of the PC board. Use the loops on the left and right sidewalls of the cabinet for anchoring field wiring using tie wraps (Detail C). These steps are important to minimize the risk of panel RF interference with television reception.

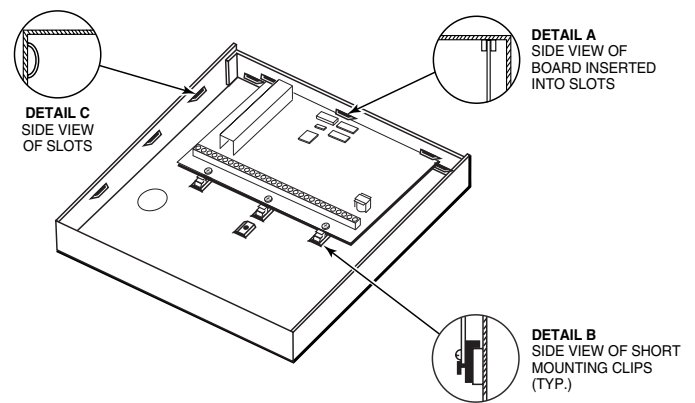

Figure 3-3: Mounting the PC Board

Installing the Keypads

- Up to 31 addressable keypads (addresses 00-30) may be used (you may need to use an auxiliary power supply if the 1A aux. output is exceeded).
- Use a 2-line alpha display, FA560KP (red for fire) (check with local AHJ for approval of keypad color).

To wire the keypads, perform the following steps:

Step	Action												
1	Determine wire gauge by referring to the Wire Run Length/Gauge table below. <table border="1" style="margin: 10px auto;"> <thead> <tr> <th colspan="2">Wire Run Length/Gauge Table</th> </tr> <tr> <th>Wire Gauge</th> <th>Length</th> </tr> </thead> <tbody> <tr> <td>#22 gauge</td> <td>450 feet</td> </tr> <tr> <td>#20 gauge</td> <td>700 feet</td> </tr> <tr> <td>#18 gauge</td> <td>1100 feet</td> </tr> <tr> <td>#16 gauge</td> <td>1750 feet</td> </tr> </tbody> </table>	Wire Run Length/Gauge Table		Wire Gauge	Length	#22 gauge	450 feet	#20 gauge	700 feet	#18 gauge	1100 feet	#16 gauge	1750 feet
Wire Run Length/Gauge Table													
Wire Gauge	Length												
#22 gauge	450 feet												
#20 gauge	700 feet												
#18 gauge	1100 feet												
#16 gauge	1750 feet												
2	Wire keypads to a single wire run or connect individual keypads to separate wire runs. The maximum wire run length from the control to a keypad, which is homerun back to the control, must not exceed the lengths listed in the table.												
3	Run field wiring from the control to the keypads (using standard 4-conductor cable of the wire gauge determined in step 1).												
4	Connect keypad(s) to terminals 11, 12, 13, and 14 on the control board, see <i>Figure 3-4</i> . NOTE: If using only one keypad, it may be connected to either Keypad Port 1 or 2, and must be mounted on, or within three feet of the cabinet. The keypad on Port 2 is electrically isolated from those on Port 1 and will continue to function even if wiring problems prevent the other keypads from working properly.												

- The length of all wire runs combined, regardless of the wire gauge, must not exceed 2000 feet when unshielded quad conductor cable is used (1000 feet if unshielded cable is run in conduit, which acts a shield, or if shielded cable is used).
- If more than one keypad is wired to one run, then the above maximum lengths must be divided by the number of keypads on the run (e.g., the maximum length is 225 feet if two keypads are wired on a #22 gauge run).

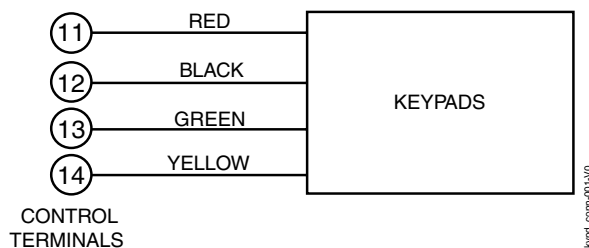

Figure 3-4: Keypad Connections to Control Panel

Addressing the Keypads



The keypads will not operate until they are physically addressed and enabled in the system's *Device Programming* in the #93 Menu Mode.

Set each keypad for an individual address (00-30) according to the keypad's instructions. Set an alpha keypad for address 00 and other keypads for higher addresses (00 and 01 are enabled in the system's default program). Any keypads set for address 02 and above will appear blank until they are enabled in the system's program. Each keypad must be set for a different address.



- Do not set any keypads to address 31 (nonaddressable mode). They will interfere with other keypads (as well as other devices) connected to the keypad terminals.
- If an "OC" or "OPEN CIRCUIT" message is present on a keypad, data from the control is not reaching the keypad. Please check your wiring.

Supplementary Power Supply for Additional Keypads

When the control's auxiliary power load for all devices exceeds 1A, you can power additional keypads from a regulated 12VDC power supply (e.g., ADEMCO AD12612 (1.2A)). Use a UL Listed, battery-backed supply for UL installations.

Connect the additional keypads as shown in *Figure 3-5*, using the keypad wire colors shown. Be sure to observe the current ratings for the power supply used.



- Make connections directly to the screw terminals as shown in *Figure 3-5*. Make no connection to the keypad blue wire (if present).
- Be sure to connect the negative (-) terminal on the power supply unit to terminal 7 (-) on the control.

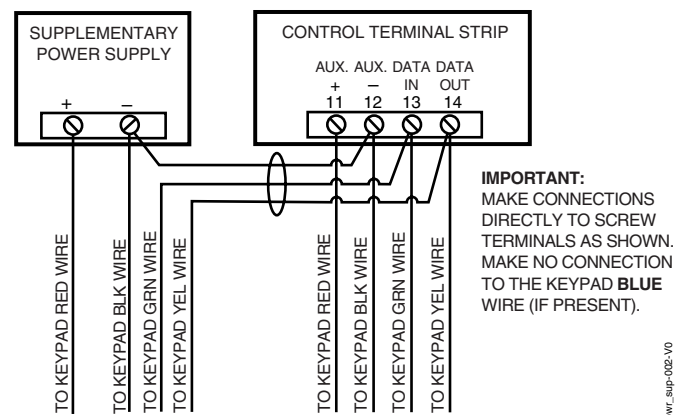

Figure 3-5: Using A Supplementary Power Supply

Installing External Sounders

The FA1700C provides two Notification Appliance Circuits for operating fire and burglary alarm notification appliances. Each circuit is rated as follows: 10VDC – 14VDC, 1.7A max. power-limited. **NOTE:** The total alarm current drawn from Auxiliary Power 1, Auxiliary Power 2, polling loop, Bell 1, and Bell 2 cannot exceed 2.3 amps for battery-independent operation.

The outputs has the following options:

- Selectable for supervision.
- Selectable to activate by individual zone assignments
- Selectable for confirmation of arming ding.
- Selectable to chime when entry/exit or perimeter zones are faulted.
- Selectable for steady or pulsing
- Selectable for no timeout or timeout of 2-30 minutes.



If you purchased a kit containing the PS24 Power Supply Module, you may use this module to convert one or both FA1700C 12VDC, 1.7A style-Y supervised Notification Appliance Circuits to 24VFW, 1.7A style-Y supervised Notification Appliance Circuits.



- Burglary Notification Appliance Circuits must be programmed for a timeout of 16 minutes or longer.
- Commercial fire alarm systems require Notification Appliance Circuits to be supervised.



This control complies with National Fire Protection Association (NFPA) requirements for temporal pulse sounding of fire notification appliances.

Wiring the Alarm Output

The wiring of the Notification Appliance Circuits depends upon whether you are going to supervise the circuit or not. Use the appropriate procedure below for your application.



Use only UL Listed sounding devices for UL installations.

Compatible Alarm Indicating Devices

Model	Device Type
ADEMCO AB12	Grade A Bell
System Sensor PA400B (beige/PA400R (red)	Indoor piezo sounder rated at 90dB @ 10 feet.
System Sensor MA-12/24	Horn
System Sensor SS1215 ADA	Strobe
System Sensor SS121575 ADA	Strobe
System Sensor MASS1215 ADA	Horn/Strobe
System Sensor MASS121575 ADA	Horn/Strobe
System Sensor MA/SS-12	Horn/Strobe
Wheelock LS1-12-VFR	Strobe
Wheelock MS1-12-VFR	Strobe
Wheelock MT-12-LS-VFR	Horn/Strobe
Wheelock MT4-12-LS-VFR	Horn/Strobe
Wheelock MT-12-MS-VFR	Horn/Strobe
WheelockMT4-12-MS-VFR	Horn/Strobe
Gentex GXS-2-15	Strobe
Gentex GXS-2-1575	Strobe
Gentex SHG-12-15	Horn/Strobe
Gentex SHG-12-1575	Horn/Strobe
Faraday 5336L-U-14-12-DC	Horn/Strobe
Faraday 5337-L-U-14-12-DC	Horn/Strobe

Notification Appliance Circuit Supervision

When supervision is enabled, the FA1700C monitors the Notification Appliance Circuits wiring for open and short circuit faults while the output is inactive. The system provides a trouble indication (Zone 970 Bell 1; 971 Bell 2) when an open occurs; or when a short occurs between the Bell (+) and Bell (-) terminal wiring, or between the Bell (+) terminal wiring and earth ground. The FA1700C indicates the trouble condition regardless of whether the system is armed or disarmed. The zone displays on the keypads, reports to the event log, and transmits to the central station (if programmed) on Partition 1. The trouble is cleared from the display by entering the user code + OFF.

BELL 1 FACTORY DEFAULTS

- BELL 1 IS CONFIGURED AS A BURGLARY BELL CIRCUIT
- USE NONPOLARIZED GRADE A INDICATING DEVICES (e.g., ADEMCO NO AB12 - SEE WIRING NOTES BELOW)
 - WIRING IS NOT SUPERVISED; CUT WHITE JUMPER, W1, ON MAIN PCB.
 - ACTIVATES FOR ZONES 3-8 ALARMS (BY DEFAULT, ZONES 3-8 ARE ASSIGNED TO BURGLARY PARTITION 1)
 - STEADY ALARM OUTPUT
 - 16-MINUTE TIMEOUT.

BELL 2 FACTORY DEFAULTS

- BELL 2 IS CONFIGURED AS A FIRE BELL CIRCUIT
- USE POLARIZED INDICATING DEVICES.
 - CLASS B OPEN/SHORT SUPERVISION.
 - 24-HR TROUBLE RESPONSE TO FAULTS.
 - ACTIVATES FOR ZONE 1-2 ALARMS (BY DEFAULT, ZONES 1-2 ARE ASSIGNED TO FIRE PARTITION 1)
 - PULSED ALARM OUTPUT.
 - NO TIMEOUT

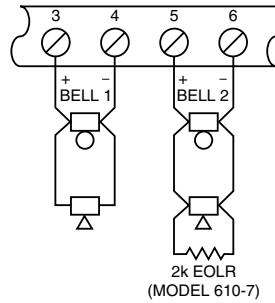

AB12 WIRING NOTES:

- DISCONNECT THE AB12'S FACTORY-WIRED CONNECTION FROM ITS TERMINAL #4 TO ITS OUTER BOX.
- SET FIELD 3* 17 TO "1" TO ENABLE ZONE 6 TAMPER FUNCTION.
- ASSIGN ZONE 6 TO A BURGLARY PARTITION. PROGRAM IT FOR DAY TROUBLE/NIGHT ALARM RESPONSE (TYPE 05) WHEN THIS BELL IS USED BY ONLY ONE BURGLARY PARTITION. PROGRAM IT FOR 24-HR. AUDIBLE ALARM RESPONSE (TYPE 07) WHEN THIS BELL IS USED BY MORE THAN ONE BURGLARY PARTITION.
- ALL WIRING FROM AB12 TO PANEL MUST BE RUN IN CONDUIT.

AB12 BELL/BOX WIRING

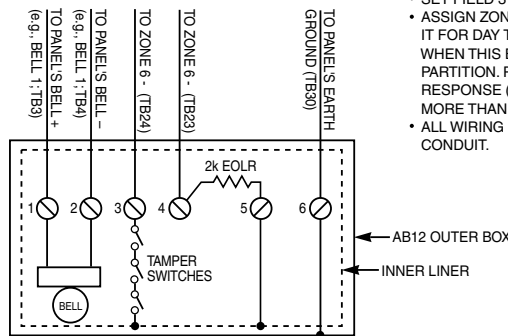

Figure 3-6: External Sounder Connections

Supervising the Notification Appliance Circuits

To wire the NAC using the supervision feature, perform the following steps:

Step	Action
1	Install a 2K EOL resistor (Model 610-7, supplied) across the last notification appliance on each Notification Appliance Circuit to be supervised.
2	Program Zone 970 (Bell 1) and zone 971 (Bell 2) with a response type of 19 (24-Hour Trouble).

Disabling the Supervision of the Notification Appliance Circuits

To install the NAC and disable the supervision feature, perform the following steps:

Step	Action
1	Cut the white jumpers W1 (for Bell 1) and W2 (for Bell 2) on the main PC board.
2	Program Zone 970 (Bell 1) and zone 971 (Bell 2) with a response type of 00.



The Notification Appliance Circuits will not respond unless the zones are assigned to them. For fire alarms, the system displays "FIRE ALARM SILENCED." This message also displays if the Notification Appliance Circuit is not supervised.

Auxiliary Relay Connections

The FA1700C provides a built-in Form C relay with contacts rated at 28VAC/VDC, 2.8A. The relay may be programmed (field 3*61) for one of the following functions:

- Alarm Activation
- Trouble/Supervisory Activation
- 4-Wire Smoke Detector Reset
- Battery Saver

Alarm Activation

(3*61 = 1 or 4) Steady activation in response to an alarm.

If field 3*61 = 1, the auxiliary relay remains active until Aux. Relay Timeout expires or until **User Code + OFF** is entered. This option can be used to provide an unsupervised Notification Appliance Circuit for supplementary strobes, sounders, etc. when wired to the Aux Power 1 or a separate power supply, see Figure 3-7.

If field 3*61 = 4, the auxiliary relay remains activated until **User Code + # + 67** is entered. This option can be used for elevator recall or ventilator shutdown on fire alarms. By default, the relay is set to activate on alarm zones 1-8 with no timeout (field 3*61 = 1).

When field 3*61 = 1, the auxiliary relay can be programmed to give a brief activation for confirmation of arming ding (field 3*57) or Chime Mode (field 3*59).

- AUX RELAY FACTORY DEFAULTS**
- ACTIVATES FOR ZONES 1-8 ALARMS (STEADY ALARM OUTPUT).
 - NO TIMEOUT.

- NOTES:**
- USE NON-POLARIZED INDICATING DEVICES.
 - WIRING IS NOT SUPERVISED.
 - DO NOT EXCEED RATINGS OF THE SUPPLY USED. IF AUX. PWR. 1 OUTPUT IS USED, THE COMBINED ALARM CURRENT DRAIN FROM AUX. PWR. 2, BELL 1, AND BELL 2 CANNOT EXCEED 2.3A MAX.

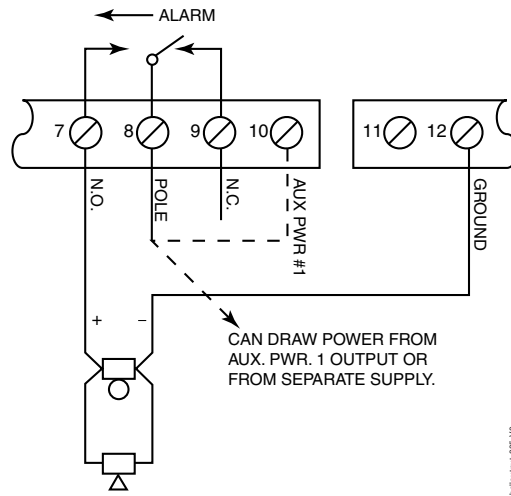

Figure 3-7: Wiring Auxiliary Relay for Alarm Activation

Trouble/Supervisory Activation

(3*61 = 0) Steady activation in response to any zone or system related trouble condition or to any fire supervisory condition. The auxiliary relay remains activated until all fault conditions have been corrected and a **User Code + OFF** is entered.

4-Wire Smoke Detector Reset

(3*61 = 2) Momentary (6-second) activation in response to a second entry of a **User Code + OFF** sequence following a fire alarm condition. This interrupts power to 4-wire smoke detectors connected to hardwired zones 1-8 and polling loop zones, allowing the detectors to be reset. Power to the detectors should be wired to the auxiliary relay and to Aux. Power 1 output, see Figure 3-8.

Battery Saver

(3*61 = 3) When this option is selected, the auxiliary relay is normally activated (e.g., N.O. and pole contacts are connected) and de-activates 4 hours after the start of AC Loss. Using this feature, non-critical loads, such as supplementary keypads, can be disconnected from the auxiliary power outputs, allowing a smaller capacity battery to be used. The relay re-activates within a few seconds after the AC power restores.

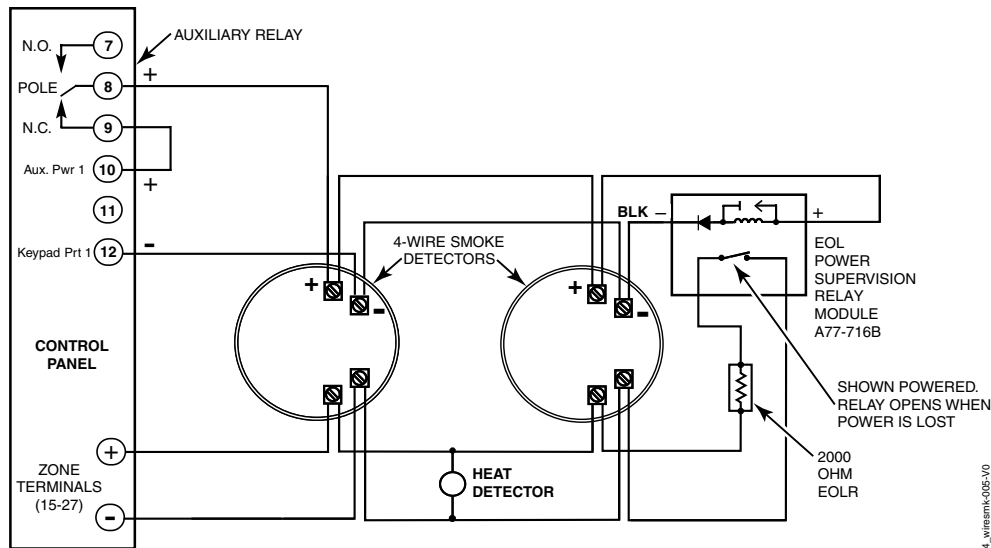

Figure 3-8: Wiring Auxiliary Relay for Smoke Detector Reset

Telephone Line Connections

The FA1700C provides one main built-in dialer for communication to the central station and one optional 5140DLM Backup Dialer, both supervised for voltage and current on the phone lines.



Do not connect the system to telephone lines that require ground start service.

UL

For Listed fire central station (UL864/NFPA 72) applications, use either a Long Range Radio (LRR) alone, the main dialer with the LRR, or use the main dialer with the 5140DLM.

For listed fire remote station (UL864/NFPA 72) applications, use the main dialer with the 5140DLM.

Telephone line supervision is required for UL commercial fire alarm systems when dual line dialer is used for fire signal transmission.

Main Dialer Connections

To connect the main dialer, refer to the *Summary of Connections* diagram and perform the following steps:

Step	Action
1	Connect the main dialer to the telephone company lines using the RJ31X cable supplied.
2	If the dialer output is connected to telephone lines that have a telephone company MTU installed, cut the blue jumper (W6).

Installing the 5140DLM Backup Dialer



Do not connect the main dialer and the backup dialer to the same telephone company line.

To install the 5140DLM, refer to the *Summary of Connections* diagram and perform the following steps:

Step	Action
1	Mount the 5140DLM to the main PC board shield.
2	Connect the backup dialer to the telephone company lines using the RJ31X cable supplied.
3	Connect the backup dialer to the J3 connector on the main PC board using the ribbon cable (supplied with the module).
4	Connect the earth ground screw on the 5140DLM to the earth ground terminal (30) on the main PC board using 16AWG wire.
5	If the dialer output is connected to telephone lines that have a telephone company MTU installed, cut the blue jumper on the 5140DLM PC board.

Telephone Line Supervision

If the tip/ring voltage falls below approximately 25 volts (13 volts if the blue jumper is cut) or the handset current is less than approximately 10mA, the supervision circuits for the dialer output will indicate a fault condition. Faults on the phone lines are displayed as zones 97 (main dialer) and 975 (backup dialer).



- To prevent risk of shock, disconnect the phone lines at the telco jack before servicing the panel.
- If the communicator is connected to a telephone line inside a PABX, be sure the PABX has backup power supply that can support the PABX for 24 hours (central station usage) or 60 hours (remote station usage). Many PABXs are not power-backed up, and connection to such a PABX results in a communication failure if power is lost.

UL

The telephone line inputs have overvoltage protection in accordance with UL1459, as specified in UL985/UL1023.

Reporting Formats



The system is shipped defaulted for Contact ID format. It is the only format capable of uniquely reporting all 250 zones, as well as openings and closings for all 250 users. This requires central stations to be equipped with the ADEMCO 685 receiver using software level 4.10 or higher. If you need to update your 685 Receiver, contact your distributor.

The system supports ADEMCO Low Speed 3+1; 4+1; 4+2; SESCOA/RADIONICS 3+1; 4+1; 4+2; ADEMCO 4+2 Express; ADEMCO High Speed; ADEMCO Contact ID.formats

Dialer Operation

When only the main dialer is enabled (field 3*30 = 1,0), the system attempts to route all messages over the main dialer output. When both the main and backup dialers are enabled (field 3*30 = 1,1), the system attempts to route all calls over the main dialer output until a fault condition is detected on the main dialer, at which time it attempts to use the backup dialer.

The communicator makes up to 8 attempts to transmit the messages to one or both telephone numbers (primary and secondary), depending on the report routing options programmed. After the 8th attempt, the communicator hangs up and the system displays "COMM FAIL" on the keypad. The number of dialer attempts are programmed in field 3*21 (default = 8; must be restricted to 3, 4, or 5 if a secondary phone number is programmed).



The system does not switch to the backup dialer unless a fault condition is detected on the main dialer. The backup dialer will not be activated because of a programming error.

Wiring Burglary and Panic Devices to Zones 1-8



The maximum zone resistance is 100 ohms for zones 1, 2 and 8, and 300 ohms for all other zones (excluding the 2K EOL resistor).

To wire burglary and panic devices to zones 1-8, connect sensors/contacts to the hardwire zone terminals (15 through 27). Connect N.C. and N.O. devices as follows:

- Connect N.C. devices **in series** with the high (+) side of the loop. The 2K EOL resistor must be connected in series with the devices, following the last device.
- Connect N.O. devices **in parallel (across)** the loop. The 2K EOL resistor must be connected across the loop wires at the last device.

Using 2-Wire Smoke Detectors on Zones 1 and 2

Zone 1 and 2 can support up to 16 2-wire smoke detectors each (32 total).



The alarm current on zones 1 and 2 supports only one smoke detector in the alarmed state.

When assigned zone type 9 or 16, the second entry of a User Code + off at a keypad interrupts power to these zones to allow detectors to be reset following an alarm.

Compatible 2-Wire Smoke Detectors

DETECTOR TYPE	DEVICE MODEL #
Photoelectric, direct-wire	System Sensor 2400
Photoelectric w/heat sensor, direct-wire	System Sensor 2400TH
Photoelectric w/B401B base	System Sensor 2451
Photoelectric w/heat sensor & B401B	System Sensor 2451TH
Ionization, direct-wire	System Sensor 1400
Ionization w/B401B base	System Sensor 1451
Photoelectric duct detect (DH400 base)	System Sensor 2451
Photoelectric duct detect (DH400 base)	System Sensor 2451
Ionization duct detector (DH400 base)	System Sensor 1451DH
Ionization, direct-wire	System Sensor 1100
Ionization w/B110LP base	System Sensor 1151
Photoelectric, direct-wire	System Sensor 2100
Photoelectric w/heat sensor, direct-wire	System Sensor 2100T
Photoelectric w/B110LP base	System Sensor 2151



These smoke detectors are UL Listed for use with the FA1700C and are the **only** 2-wire smoke detectors that may be used.

Wiring 2-Wire Smoke Detectors to Zones 1 and 2



2K EOL resistors must be used on fire zones and must be connected across the loop wires of each zone at the last detector.

To wire 2-wire smoke detectors to zone 1 and/or zone 2, perform the following steps:

Step	Action
1	Select 2-wire smoke detectors from the list of compatible detectors.
2	Connect 2-wire smoke detectors across zone 1 (terminals 15 and 16), and/or zone 2 (terminals 17 and 18) as shown in <i>Figure 3-9</i> . Observe proper polarity when connecting the detectors.
3	Connect the EOL resistor at the last detector in the loop across the zone 1 terminals. The EOL resistor must be connected across the loop wires at the last detector.

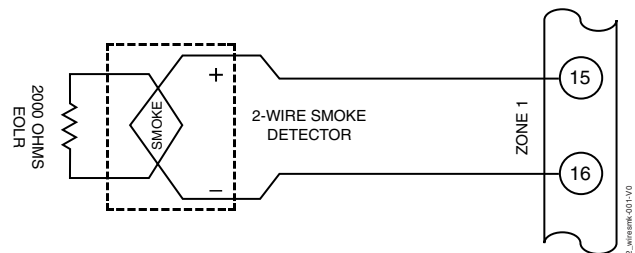

Figure 3-9: 2-Wire Smoke Detector on Zone 1 (for zone 2 use terminals 17 & 18)

Using 4-Wire Smoke Detectors on Zones 1-8

You may use as many 4-wire smoke detectors as can be powered from the panel's Auxiliary Power output without exceeding the output's rating (1A).



Auxiliary power to 4-wire smoke detectors is not automatically reset after an alarm, and therefore must be momentarily interrupted using either the J2 smoke detector reset output trigger, the auxiliary relay or a 4204 Relay Module.

Compatible 4-Wire Smoke Detectors

Use any UL Listed 4-wire smoke detector that is rated for 10-14VDC operation and that has alarm reset time not exceeding 6 seconds. Some compatible 4-wire smoke detectors are listed below.

Detector Type	Detector Model #
Photoelectric, direct wire	System Sensor 2412
Photoelectric w/heat sensor, direct wire	System Sensor 2412TH
Ionization, direct wire	System Sensor 1412

Wiring 4-Wire Smoke Detectors

UL

Power to 4-wire smoke detectors must be supervised with an EOL device (use a System Sensor A77-716B EOL relay module connected as shown in *Figure 3-10*).

To wire 4-wire smoke detectors to zones 1-8, perform the following steps:

Step	Action
1	Select 4-wire smoke detectors (see list of compatible detectors shown previously in this section).
2	Connect detectors (including heat detectors, if used) across terminals of the zone selected. All detectors must be wired in parallel. See <i>Figure 3-10</i> . NOTE: If you are using the J2 output trigger to reset the smoke detectors, refer to <i>Smoke Detector Reset</i> later in this section for the wiring instructions. If you are using the auxiliary relay to reset the smoke detectors, refer to <i>Installing the Auxiliary Relay</i> previously in this section for wiring instructions.
3	Connect the EOLR at the last detector in the loop across the zone's terminals. You must connect the EOLR across the loop wires at the last detector.

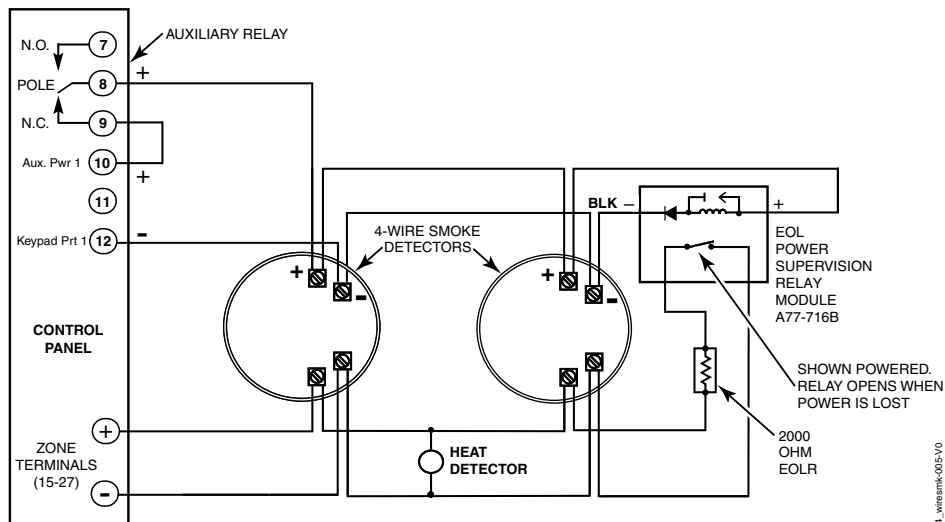

Figure 3-10: Wiring 4-Wire Smoke Detectors

Using Smoke Power Reversal Module

The 333 PRM Polarity Reversing Module is used to reverse the polarity of the positive and negative voltages powering smoke detectors. The module is for use with 4-wire smoke detectors that employ a sounder and voltage-reversing feature. The module is triggered by a pulsing Notification Appliance Circuit.



The 333PRM reverses polarity to smoke detectors with Integral Temp-3 Sounders. Typically, in alarm, each draws 49-60mA of current. The control panel supplies only enough current for one smoke detector. In order to attach more than one, an external power supply and an external relay may be required.

Smoke Detectors Compatible with the 333PRM

The 333PRM may be used with the System Sensor 2112/24AT and similar models with the required operating features previously stated.

Installing the 333 PRM

Mount the 333 PRM inside the control panel's cabinet or in a separate cabinet using the double-sided tape provided. Wire the 333PRM as shown in *Figure 3-11* or *Figure 3-12*. Refer to the *333PRM Installation Instructions* for detailed information on the installation of the module.

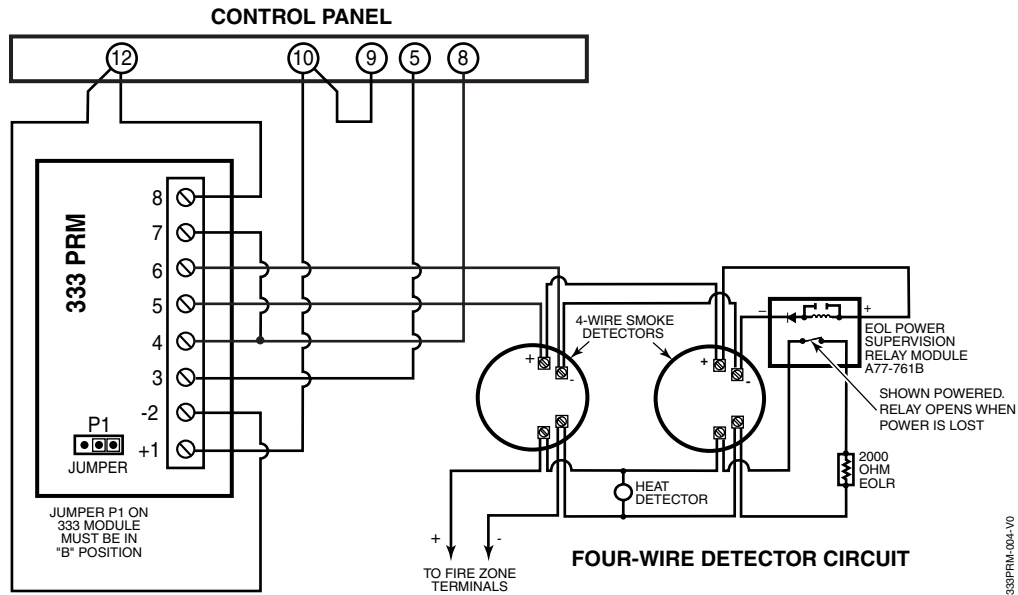

Figure 3-11: Wiring a 333PRM to the Control

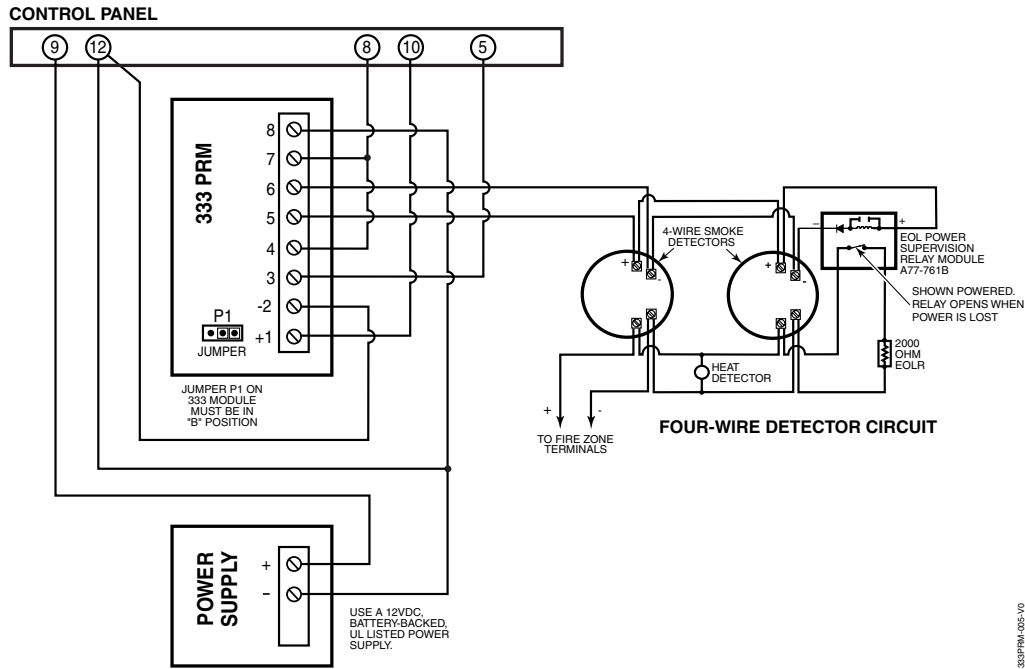

Figure 3-12: Wiring a 333PRM using a Power Supply

Zone 6 Tamper Configuration

Zone 6 may be used as a tamper loop for the FA1700C Cabinet Door Tamper Switch and for the ADEMCO AB12 Grade A Burglary Bell Box Tamper Switches and Tamper Liner. The bell Housing’s tamper switch and inner tamper linings must also be wired to zone 6.

Assign zone 6 to a burglary partition. Program it for day trouble/night alarm (zone type 5) when only one burglary partition is used. Program it for 24-hr. audible alarm (zone type 7) when more than one burglary partition is used. Enable the Zone 6 Alternate Tamper Function (program field 3*17.

When set in this manner, and the zone senses an open or short, or an earth ground fault occurs by drilling through the AB12 housing, the system triggers a trouble when the system is disarmed and an alarm when it is armed. (See the *Installing the External Sounders* for wiring the ADEMCO AB12.)

Using 2-Wire Latching Glassbreaks on Zone 8

Zone 8 can support 2-wire glassbreak detectors. The zone provides enough standby current to power up to 50 2-wire glassbreak detectors meeting the requirements listed below.

Compatible Glassbreak Detectors

Use detectors that meet the following ratings:

Standby Voltage:	5VDC–13.8VDC
Standby Resistance:	Greater than 20k ohms (equivalent resistance of all detectors in parallel)
Alarm Resistance:	Less than 1.1k ohms (see note below)
Alarm Current:	2mA–10mA
Reset Time:	Less than 6 seconds

NOTES:

- You can use detectors that exceed 1.1k ohms in alarm, provided they maintain a voltage drop of less than 3.8 volts in alarm.
- The IEI 735L Series detectors have been tested and found to be compatible with these ratings.

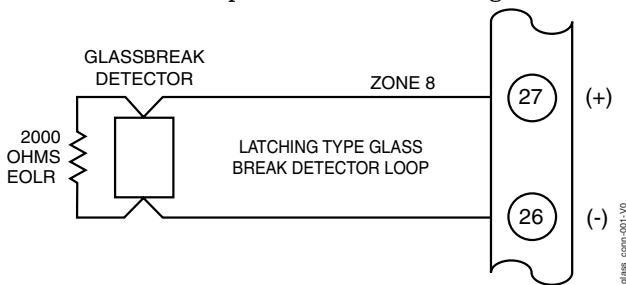

Figure 3-13: Wiring Latching Glassbreaks to Zone 8



- The alarm current provided by zone 8 supports only one glassbreak detector in the alarmed state.
- Do not use other N.O. or N.C. contacts when using glassbreak detectors on zone 8. Other contacts may prevent proper glassbreak detector operation.

To wire 2-wire latching glassbreak detectors to zone 8, perform the following steps:

Step	Action
1	Select compatible 2-wire glassbreak detectors that meet the requirements stated previously.
2	Connect detectors across zone 8 (terminals 27 and 28). See Figure 3-13.
3	Connect the EOL resistor at the last detector in the loop across the zone's terminals. You must connect the EOL resistor across the loop wires at the last detector.

Tamper Supervision for the Hardwired Zones

The system can be programmed to monitor for either an open condition or a short condition of a tamper switch on zones 1-8. End-of-line supervision is required for this option.

Wiring a Tamper Switch to Zones 1-8

The wiring of the tamper switch depends on whether the tamper switch and the sensor are normally open or normally closed.

- If you are using a normally closed sensor**, the tamper switch must be normally open. Refer to Figure 3-14 for the wiring configuration.
- If you are using a normally open sensor**, the tamper switch must be normally closed. Refer to Figure 3-15 for the wiring configuration.

To wire a tamper switch on a hardwired zone, connect the EOL resistor at the last detector in the loop across the zone's terminals. **You must connect the EOL resistor at the last detector for proper operation of the tamper supervision.**

NOTE: For the normally closed sensor, program the zone for trouble on short. For the normally open sensor, program the zone for trouble on open.

NOTE: For zones with a response type of 9 or 16 (Fire), the tamper selection must be "0" none.

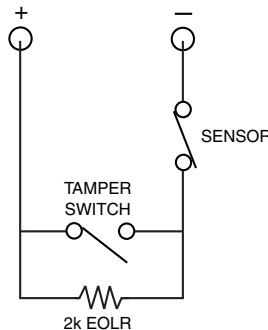

Figure 3-14: Wiring a Normally Closed Sensor Loop for Tamper Supervision

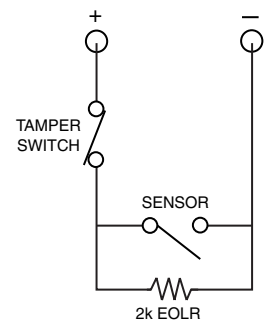

Figure 3-15: Wiring a Normally Open Sensor Loop for Tamper Supervision

Installing RPM Devices

The polling loop provides both power and data to the RPM devices, and is constantly monitoring the status of all zones enabled on the loop. The maximum current draw of all devices on the polling loop cannot total more than 128mA (unless the system uses a 4297 Polling Loop Extender Module).



Devices that can be programmed via either DIP switches or the built-in unique serial number **must** be set for serial number mode operation.

All devices on the polling loop must be wired in parallel to the [+] and [-] polling loop terminals of the control panel (28 and 29). You can wire from device to device, or have multiple branches connected directly to the control panel in a star configuration.



Do not run polling loop wires within 6" of AC power, telephone, or intercom wiring. The polling loop is carrying data between the control panel and the devices. Interference on this loop can cause an interruption of this communication. The polling loop can also cause outgoing interference on the intercom or phone lines. If this spacing cannot be achieved, shielded wire must be used. (Note that the maximum total wire length supported is cut in half when shielded wire is used.)



The Quest 2260SN can be programmed as a "Smart Contact" in *Zone Programming*. This prevents those PIRs from displaying faults during the disarmed state. You cannot mix Quest 2260SN "Smart Contacts" with non-"Smart Contacts" in the system.

UL

- The 4208 must be mounted either inside the FA1700C cabinet or in a separate enclosure that has a tamper-supervised cover.
- The 4190WH right loop must not be used, and the left loop must be EOLR-supervised.
- The 4278 right loop cannot be used.
- The 4194 is not UL Listed.
- The 4297 must be powered from the FA1700C Auxiliary Power Output or from a UL Listed supplementary power supply.
- The 7500 and 9500 detectors are not UL Listed.



- Twisted-pair is recommended for all wire runs.
- No more than 64mA may be drawn on any individual wire run.
- When a star configuration is used, the total length of all wire runs combined cannot exceed 4000 ft (2000 ft. if you are using unshielded wire in conduit or shielded wire).

Compatible Polling Loop Devices

Model Number	Type
4208	8-Zone Expander
4190WH	2-Zone Expander
4278	Quad PIR
4275	Dual PIR
4194	Surface-Mount Reed Contact (Wide Gap)
4297	Extender Module
4192SD	Photoelectric Smoke Detector Devices
4192SDT	Photoelectric Smoke Detector w/Heat Detector
4192SDTM	Same as above and provides maintenance signals
5192	Same as above and provides maintenance signals
4192CP	Ionization Smoke Detector
4192CPM	Same as above and provides maintenance signals
4101SN	Serial Number Single-Output Relay Module
4208U	Universal 8-Zone Expander
4939SN-BR 4939SN-GY	Serial Number Surface-Mount Reed Contacts
4191SN-WH	Serial Number Recessed Reed Contact
4959SN	Aluminum Overhead Door Contact
7500	Single Technology Glassbreak Detector
9500	Dual Technology Glassbreak Detector
4209U	Universal Group Zoning Module
4193SN	Serialized 2-Zone Expander
4293SN	Serialized 1-Zone Expander
4190SN	Serialized 2-Zone Expander
998MX	Serialized PIR

To install polling loop devices, perform the following steps:

Step	Action												
1	Select devices from the list of compatible devices shown previously.												
2	Set the DIP switches in the device (if required). Refer to the device's instructions for the DIP Switch Tables.												
3	Mount each device in the desired location. Refer to the device's instructions.												
4	Run wires from the control panel to each device on the polling loop (see <i>Figure 3-16</i>). No individual wire run may exceed the lengths shown in the following table. <table border="1" data-bbox="987 1671 1446 1892"> <thead> <tr> <th colspan="2">Maximum Polling Loop Wire Runs</th> </tr> <tr> <th>Wire Gauge</th> <th>Max. Length</th> </tr> </thead> <tbody> <tr> <td>#22 gauge</td> <td>650 feet</td> </tr> <tr> <td>#20 gauge</td> <td>950 feet</td> </tr> <tr> <td>#18 gauge</td> <td>1500 feet</td> </tr> <tr> <td>#16 gauge</td> <td>2400 feet</td> </tr> </tbody> </table>	Maximum Polling Loop Wire Runs		Wire Gauge	Max. Length	#22 gauge	650 feet	#20 gauge	950 feet	#18 gauge	1500 feet	#16 gauge	2400 feet
Maximum Polling Loop Wire Runs													
Wire Gauge	Max. Length												
#22 gauge	650 feet												
#20 gauge	950 feet												
#18 gauge	1500 feet												
#16 gauge	2400 feet												

Step	Action
5	<p>Wire each device to the polling loop, making sure of the correct polarity (refer to the device's instructions).</p> <p>NOTE: If you are using serial number devices, and intend to enroll each device through the keypad automatically, wire no more than 25 of these devices to the control at a time. Then power up and program them before connecting the next 25. Leave previously enrolled devices connected. If you intend to manually enter the serial numbers through the keypad or through Compass downloading software, all the devices may be connected before powering up to program.</p>

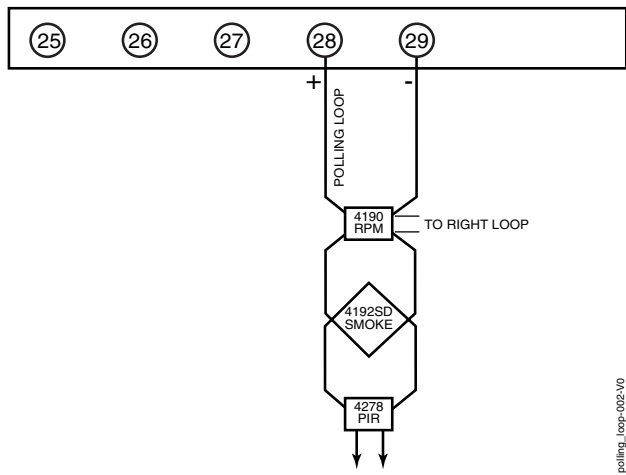

Figure 3-16: Polling Loop Connections to the Control Panel

Polling Loop Supervision

A short on the polling loop is indicated by a trouble on zone 997 and reports as a trouble condition only. If annunciation is desired, program the zone as type 05 or type 19.

If a device on the polling loop fails (the panel cannot "see" that device), the system displays a trouble condition for all zones on that device. If the panel is armed when a device fails, and the zone is a burglary zone, the will go into alarm



A trouble on zone 997 prevents a partition from being armed, unless all polling loop zones on that partition are bypassed.

Using the 4297 Polling Loop Extender

The 4297 Polling Loop Extender may be used to provide additional polling loop current, to extend the polling loop wire run length, and/or to provide individual electrically isolated polling loops. Refer to Figures 3-17 and 3-18, to follow.



DO NOT use the 4197 Polling Loop Extender module with the FA1700C.



Be sure to include the total current drawn on the polling loop when figuring the total auxiliary load on the panel's power supply.

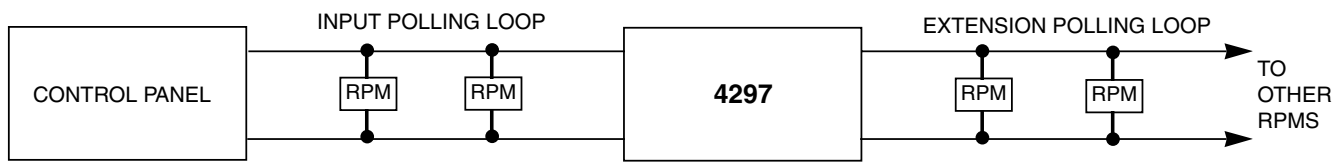

INPUT LOOP LIMITS:

- 128 mA MAX. LIMIT CURRENT TO 64mA ON ANY INDIVIDUAL WIRE RUN.
- NO MORE THAN 64 DEVICES MAY BE USED.
- NO INDIVIDUAL WIRE RUN CAN EXCEED:

GAUGE	LENGTH
#22	650 FT
#20	950 FT
#18	1500 FT
#16	2400 FT

- TOTAL LENGTH OF ALL WIRE RUNS COMBINED CANNOT EXCEED 4000FT. (2000FT. IF USING SHIELDED WIRE)

EXTENSION POLLING LOOP LIMITS = SAME AS INPUT LOOP

COMBINED INPUT AND EXTENSION LOOP LIMITS:

- NO MORE THAN 242 DEVICES COMBINED.
- TOTAL LENGTH OF ALL WIRE RUNS ON BOTH LOOPS COMBINED CANNOT EXCEED 6400 FT. 3200 FT. IF USING UNSHIELDED WIRE IN CONDUIT, OR IF USING SHIELDED WIRE

polling_loop_008-V0

Figure 3-17: Polling Loop Connections Using One 4297 Extender Module

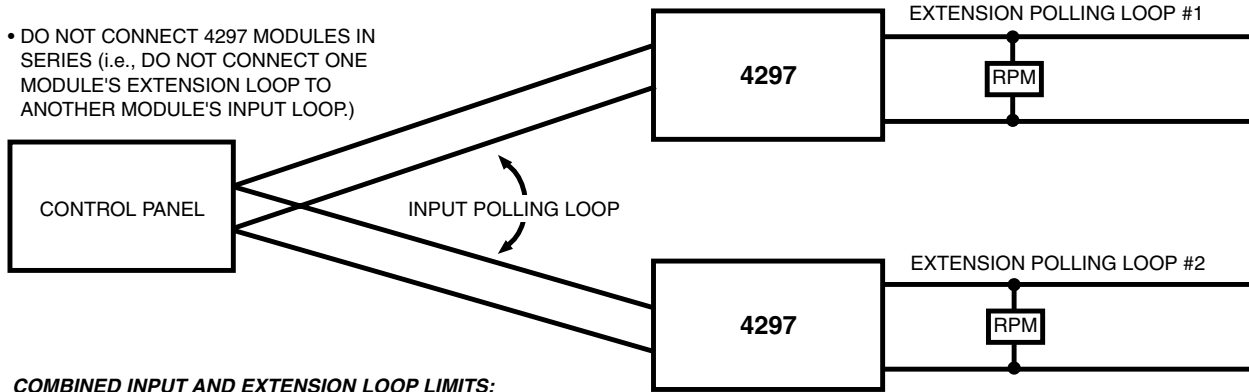

- COMBINED INPUT AND EXTENSION LOOP LIMITS:**
- NO MORE THAN 242 DEVICES COMBINED ON THE INPUT LOOP AND EXTENSION LOOP #1. NO MORE THAN 242 DEVICES COMBINED ON THE INPUT LOOP AND EXTENSION LOOP #2.
 - TOTAL LENGTH OF ALL WIRE RUNS ON THE INPUT LOOP AND EXTENSION LOOP #1 COMBINED CANNOT EXCEED 6400 FT. (3200 FT. IF USING UNSHIELDED WIRE IN CONDUIT, OR SHIELDED WIRE). TOTAL LENGTH OF ALL WIRE RUNS ON THE INPUT LOOP AND EXTENSION LOOP #2 COMBINED CANNOT EXCEED 6400 FT. (3200 FT. IF USING UNSHIELDED WIRE IN CONDUIT, OR SHIELDED WIRE).

polling_loop-009-V0

Figure 3-18: Polling Loop Connections Using Multiple Extender Modules

NOTE: The input loop limits stated in Figure 3-17 apply to Figure 3-18 as well.

Wireless Zone Expansion

UL The 5881ENHC RF Receiver and the 5869 Holdup Switch Transmitter are listed for UL Commercial Burglary applications. All other RF receivers and transmitters are not listed for UL Commercial Burglary applications.

The following table lists the receivers that may be used and the number of zones they support.

5800 Series Receivers

Receiver	Zones
5881L	up to 8
5881M	up to 16
5881H	up to 250
5881ENHC	up to 250 (use with UL864 installations)



In Canada, 5800 systems must use 5882 Series receivers. Information about the 5881 Receivers applies as well to the 5882 Receivers. Both receivers use the same transmitters.

RF System Operation and Supervision

The 5800 RF system operation has the following characteristics:

- The receiver responds to a frequency of 345MHz.
- The receiver has a nominal range of 200 feet.
- Supervised transmitters send a supervisory signal every 70-90 minutes.
- Zones 988 and 990 are used to supervise the RF reception of receivers 2 and 1, respectively. The reception is supervised for the following two conditions:

1. The receiver goes “deaf” (doesn’t hear from *any* transmitter) within a programmed interval of time (defined by program field 1*30).
2. Proper RF reception is impeded (i.e., jamming or other RF interference). The control checks for this condition every 45 seconds.

UL

A response type (05 Day/Night) must be programmed for zones 990 (1st receiver) and 988 (2nd receiver) for UL installations.

- The 5881ENHC receiver contains front and back tampers that permit its use in commercial burglary installations.
- You may only mount the 5881ENHC its own plastic housing. Otherwise, the receiver constantly reports a tamper condition.
- The control checks the receiver connections about every 45 seconds. The receiver supervisory zone is 8 + 2-digit receiver device address (for example, Device address 05 = supervisory zone 805).
NOTE: This zone must be programmed with a response type (e.g., type 05 Day/Night Trouble) before it supervises the connection to the receiver.
- Use two identical receivers to provide either a greater area of coverage or redundant protection. They must be set for different addresses.
- Any zone from 1 to 250 can be used as a 5800 Series wireless zone, with the exception of zone 64 (reserved for a wireless keypad).

RF System Installation Advisories

- Place the receiver in a high, centrally located area. Do not place it on or near metal objects. This will decrease the range and/or block transmissions.
- Install the RF receiver at least 10 feet from the control panel or any keypads, to avoid interference from the microprocessors in these units.
- If dual receivers are used:
 - a. Both must be at least 10 feet from each other, as well as from the control panel and remote keypads.
 - b. Each receiver must be set to a different device address. The receiver set to the lower address is considered the 1st RF receiver for supervisory purposes.
 - c. The House IDs must be the same.
 - d. Using two receivers *does not* increase the number of transmitters the system can support (249 zones using the 5881H, plus a wireless keypad).

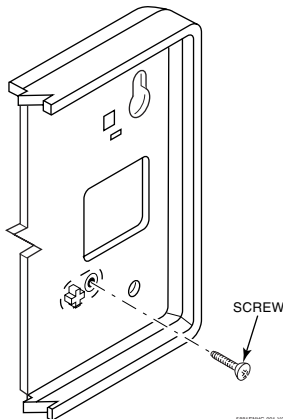

Figure 3-19: Installing the 5881ENHC with Tamper Protection

Installation and Setup of the 5881 RF Receivers



Take note of the address you select for the RF receiver, as this address must be enabled in the system's *Device Programming* in the #93 *Menu Mode*.

To install the 5881 RF receiver, perform the following steps:

Step	Action
1	Mount the receiver, following the advisories stated previously.
2	Set the DIP switches in the receiver for the address (01-07). See <i>Figure 3-20</i> . Make sure the address setting is not being used by another device (keypad, relay module, etc.).
3	If installing a 5881ENHC , install a flat-head screw (supplied) in the case tamper tab as shown in <i>Figure 3-19</i> . When the receiver is pried from the wall, the tamper tab will break off and remain on the wall. This will activate a tamper switch in the receiver and cause generation of a tamper signal. Note that this signal will also be generated when the receiver's front cover is removed.
4	Connect the receiver's wire harness to the keypad terminals (11, 12, 13 and 14). Plug the connector at the other end of the harness into the receiver.
5	Refer to the Installation Instructions provided with the receiver for installations regarding antenna mounting, etc.

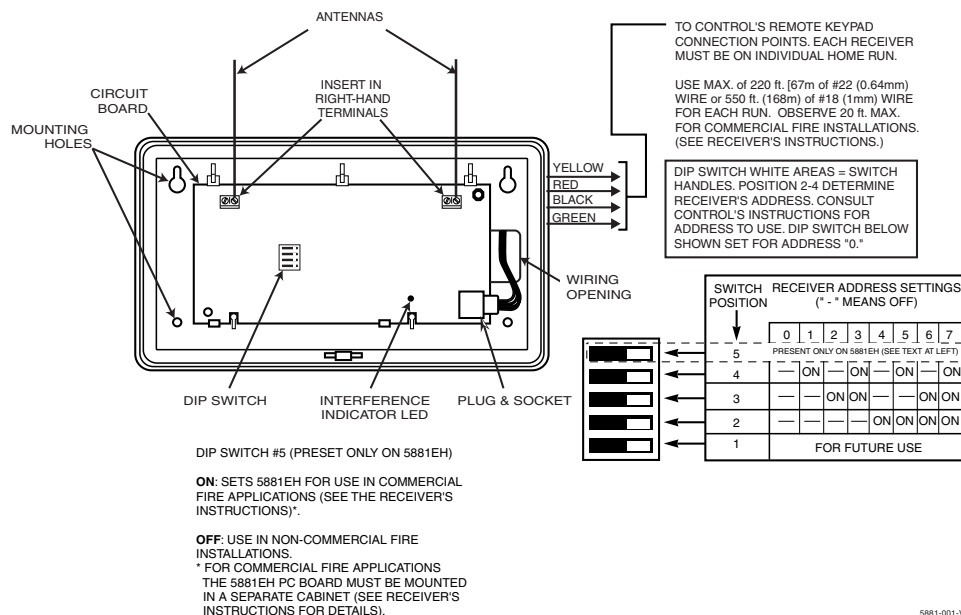

Figure 3-20: 5881 RF Receiver (cover removed)

Installing the 5800TM Module

Installation of this module is necessary only if you are using a 5827BD or 5804BD Bi-directional device.



This address for the 5800TM must be enabled in the control's *Device Programming* in the #93 *Menu Mode* as a keypad and then assigned to a partition.

To install the 5800TM, perform the following steps:

Step	Action
1	Mount the unit using its accompanying mounting bracket near the RF receiver. The 5800TM must not be installed within the control cabinet. It must be between one and two feet from the receiver's antennas.
2	Set the module for the appropriate address. For Address Setting 28 cut the red jumper; for Address 29 cut the white jumper; for Address 30 cut both jumpers. Make sure the address setting is not being used by another device (keypad, relay module, etc.).
3	Connect the module's wire harness to the keypad terminals (11, 12, 13 and 14). Plug the connector at the other end of the harness into the module.

House ID Sniffer Mode

This mode applies only if you are using a wireless keypad (5827/5827BD). Use the House ID Sniffer mode to make sure you do not choose a House ID that is in use in a nearby system. The House ID must be programmed for the receiver in *Device Programming* in the #93 *Menu Mode*.

To enter House ID Sniffer mode, enter your **Installer Code + [#] + [2]**.

The receiver now "sniffs" out any House IDs in the area and displays them. Keep the receiver in this mode for about 2 hours. Use a House ID that is not displayed. Exit the Sniffer mode by entering your **Installer Code + OFF**.



As Sniffer mode effectively disables RF point reception, Sniffer mode **cannot** be entered while any partition is armed.

5800 Series Transmitter Setup

- Transmitters have built-in serial numbers that must be enrolled in the system using the #93 *Menu Mode Programming*, or via the downloader.
- Transmitters do not have DIP switches (except 5827, described separately).
- Some transmitters can support more than one "zone" (loops or inputs) (e.g., 5816, 5817). Each loop must be assigned a different zone number.
- For button-type transmitters (wireless keys), such as the 5804 and 5804BD, you must assign a unique zone number to each individual button used on the transmitter.



The 5808 smoke detector can be programmed as a "Smart Contact" in *Zone Programming*. This enables the detector to monitor maintenance signals and may prevent false alarms from a "dirty" detector.

Transmitter Supervision

Supervised RF transmitters send a check-in signal to the receiver at 70–90 minute intervals. If at least one check-in is not received from each supervised transmitter within a programmed period (field 1*31), the "missing" transmitter number(s) and "CHECK" or "TRBL" are displayed. Unsupervised RF transmitters (5802MN, 5804) may be carried off the premises.

Some transmitters have built-in tamper protection, and announce a "CHECK" or "TRBL" condition if covers are removed.



If a loss of supervision occurs on a transmitter programmed for Fire, it reports in Contact ID as a Fire Trouble (373), not Loss of Supervision (381), to the central station.

Transmitter Input Types

All transmitters have one or more unique factory-assigned input (loop) codes. Transmitters can be programmed as one of the following types:

Type	Description
RM (RF Motion)	Sends periodic check-in signals, fault and low-battery signals. The control panel automatically restores the zone to "ready" after a few seconds. It is intended for facilities with multiple motion detectors that may fault and restore simultaneously. The transmitter must remain within the receiver's range. NOTE: RF Motion may only be used on loop 1 of a door/window type transmitter.
RF (Supervised RF)	Sends periodic check-in signals, fault, restore, and low-battery signals. The transmitter must remain within the receiver's range.
UR (Unsupervised RF)	Sends all the signals that the RF type does, but the control does not supervise the check-in signals. The transmitter may be carried off-premises.
BR (Unsupervised Button RF)	These send only fault signals. They do not send low-battery signals until they are activated. The transmitter may be carried off-premises.

Transmitter Battery Life

Batteries in the wireless transmitters may last from 4 to 7 years, depending on the environment, usage, and the specific wireless device being used. Factors such as humidity, high or low temperatures, as well as large swings in temperature may all reduce the actual battery life in a given installation.

The wireless system can identify a true low battery situation, thus allowing the dealer or user of the system time to arrange a change of battery and maintain protection for that point within the system.

Some transmitters (e.g., 5802, 5802CP, and 5803) contain long-life but nonreplaceable batteries. At the end of their life, the complete unit must be replaced (and a new serial number enrolled at the control). Button-type transmitters (e.g., 5801, 5802, 5802CP and 5803) should be periodically tested, as these transmitters do not send supervisory check-in signals.



To test the transmitters using the Transmitter ID Sniffer mode and the Go/NoGo Test Mode, see the **SECTION 10: Testing the System** for the procedures.

Compatible 5800 Series Transmitters

Model	Product	Input Type
5801	Panic Transmitter	UR or RF
5802 5802CP	Pendant (Personal Emerg. Xmitter) Belt Clip (Personal Emerg. Xmitter)	BR Only
5802MN	Miniature (Personal Emerg. Xmitter)	UR or RF
5802MN2	Miniature (Personal Emerg. Xmitter)	UR or RF
5804	Wireless Key Transmitter	BR Only
5804BD	Wireless Key Bi-directional Transmitter	BR Only
5804BDV	Wireless Key Bi-directional Transmitter with Voice	BR Only
5806/5807/ 5808	Photoelectric Smoke Detectors. 5808 is UL Listed for Fire	RF

Model	Product	Input Type
5816	Door/Window Transmitter	RF
5816MN	Miniature Door/Window Transmitter	
5816TEMP	Temperature Sensor Transmitter	
5817	Multi-Point Universal Transmitter	RF
5818	Recessed Transmitter	RF
5827	Wireless Keypad	House ID
5827BD	Wireless Bi-directional Keypad	House ID
5849	Glassbreak Detector	RF
5850	Glassbreak Detector	RF
5890	PIR Detector	RF
5890PI	PIR Detector with Pet Immunity	RF

Installing Output Devices

The FA1700C supports up to 96 outputs. Each device must be programmed as to how to act (ACTION), when to activate (START), and when to deactivate (STOP). The 4204, 4204CF, FSA-8, FSA-24, and/or 4140SN may be used as output devices.

Installing the 4204 and 4204CF Relay Modules

Each 4204 module provides 4 relays with Form C (normally open and normally closed) contacts. Each 4204CF module adds two style Y supervised Notification Appliance Circuits to the system. For 4204CF modules, only relays 1 and 3 on each module can be programmed.



The relay module will not operate until the device address you have set the DIP switches for is enabled in the control's *Device Programming* in the #93 Menu Mode.

To install the relay modules, see *Figures 3-21 and 3-22* and perform the following steps:

Step	Action
1	Set the 4204 or 4204CF's DIP switches for a device address 01-15 . Do not use an address being used by another device (keypads, RF receivers, etc.).
2	Mount the 4204 and 4204CF modules per the instructions provided with them.
3	Connect the module's wire harness to the control (11, 12, 13 and 14). Plug the connector on the harness to the module. When mounting remotely, homerun each module to the control. The table below shows the maximum wire run lengths. Refer to the instructions provided with the 4204CF for its maximum permissible wire lengths.

Wire Gauge	Maximum Length
#22	125 feet
#20	200 feet
#18	300 feet
#16	500 feet

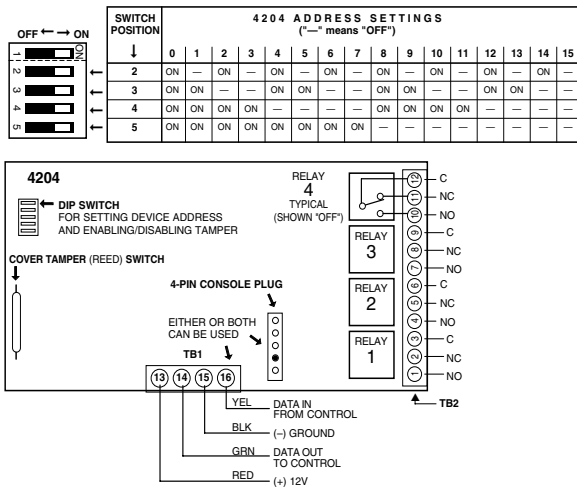

Figure 3-21: 4204 Relay Module

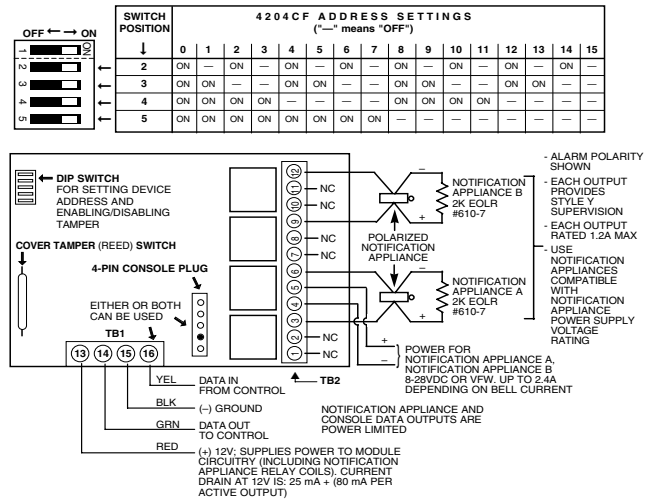

Figure 3-22: 4204CF Relay Module

Installing the FSA Modules

The 8-zone LED Fire System Annunciator FSA-8 and 24-zone LED Fire System Annunciator FSA-24 enable a fire response unit to identify quickly the point/zone of a fire. These indicators may be used for other functions as well, such as status indication. A maximum of 4 FSA modules, in any combination, can be supported.

To install the FSA module, refer to *Figure 3-23* and perform the following steps:

Step	Action
1	Set the FSA's DIP switches for a device address from 08 to 23. See the module's instructions for the DIP switch table. Do not use an address being used by another device (keypads, RF receivers, etc.).
2	Mount the FSA module horizontally to a duplex box (quad box for FSA-24).
3	Connect the module to the control's keypad terminals (11, 12, 13 and 14).

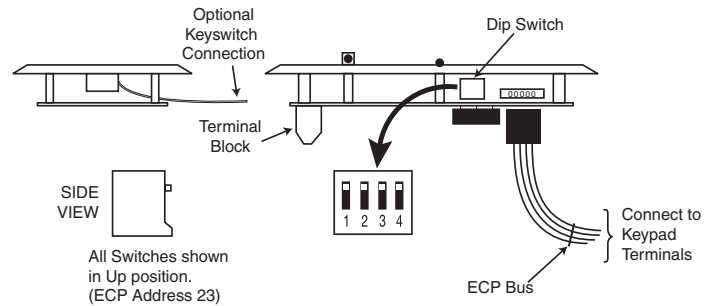

Figure 3-23: Wiring the FSA Module

The FSA module will not operate until the device address you have set the DIP switches for is enabled in the control's *Device Programming* in the #93 Menu Mode.

Installing 4101SN Relay Modules

The 4101SN V-Plex Single Output Relay Module is a serial number polling loop output device. The 4101SN features the following:

✓ The position of the relay is supervised, but not the actual external contact wiring.

- Form C relay contacts rated at 2A, 28VAC/VDC with contact supervision.
- One class B/style B EOLR-supervised auxiliary input zone.
- Operating power and communication with control panels via the V-Plex polling loop.

- Electronics mounted in a small plastic case with tamper-protected cover.

- If are using ZONE # for the START of a polling loop output, and want the output to stop when the same zone restores, the STOP programming **must be blank**.
- No more than 20 polling loop outputs may be programmed for the same START or STOP condition in *Output Programming*.

Connect the device to the polling loop, terminals 28 (+) and 29 (-). Be sure to observe polarity

Installing a Remote Keyswitch

A UL-Listed remote keyswitch, such as the ADEMCO 4146, can be used for remote arming/disarming of the burglary part of the system and for silencing alarms. The keyswitch operates in only one particular partition. The keyswitch is wired across zone 7. This zone is no longer available as a protection zone. Be sure to program Zone 7 with a response type (e.g., type 10).

Operation

- A momentary short arms the partition in the AWAY mode, and a short held for more than 10 seconds arms the partition in STAY mode 1. A subsequent short disarms the partition.
- The keyswitch LEDs indicate the partition's status (see table that follows).
- A momentary short silences Notification Appliance Circuits and keypad sounds, and disarms the system if it was armed. A subsequent short clears the alarm memory indication and resets 2-wire smoke and glassbreak detectors (if used).
- The keyswitch can be used to silence fire alarms without disarming the burglary portion (program a "9" in field *15). A momentary short silences alarm outputs only if a fire alarm is present.

UL

In UL commercial fire installations, mount the keyswitch next to the keypad. The keypad displays the UL-required "FIRE BELL SILENCED" when the keyswitch is used to silence a fire alarm.

LED Indications

Green	Red	Indication
On	Off	Disarmed & Ready
Off	Off	Disarmed & Not Ready
Off	On Steady	Armed Away
Off	Slow Flash	Armed Stay
Off	Rapid Flash	Alarm Memory



The keyswitch reports as user 0, if Open/Close reporting is enabled in field *40.

Keyswitch Tamper Operation

The tamper switch need not be used for fire or UL Household Burglary installations. For UL Commercial Burglary installations, the tamper switch must be wired to zone 6, see *Figure 3-24*.

Program zone 6 for Day Trouble/Night Alarm (response type 5). When the keyswitch is removed from the wall, the tamper switch opens, causing an alarm or trouble on the zone. This also causes the control to disable keyswitch operation until the tamper is restored and the associated partition is disarmed.

Wiring for the Remote Keyswitch

To install the ADEMCO 4146 keyswitch, perform the following steps:

Step	Action
1	Connect the ADEMCO 4146 to the panel as shown in <i>Figure 3-24</i> .
2	If you are using the tamper, make sure it is connected to a zone.

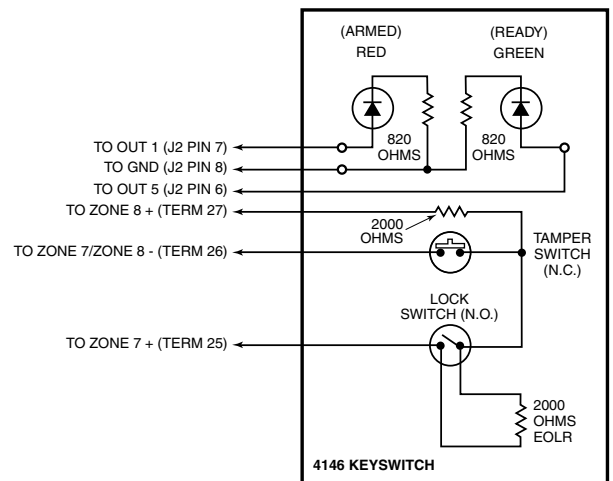

Figure 3-24: Remote Keyswitch Wiring

Installing a 5140LED Indicator Module

An optional 5140LED Indicator Module can be installed in municipalities, which require dedicated indicators for communicator fault status. The 5140LED provides the following indicators:

AC POWER:

- ON if AC Power is present.
- OFF if AC Power is not present.

COMM FAILURE:

- ON if maximum number of attempts were made (field 3*21) to transmit a message to the central station. Enter **User Code + OFF** following a successful transmission to turn off.
- OFF is normal.

DIALER 1 FAULT:

- ON if main dialer line is faulted. Correct problem and then enter **User Code + OFF** to turn off.
- OFF if normal.

DIALER 2 FAULT

- ON if backup dialer line is faulted. Correct problem, and then enter **User Code + OFF** to turn off.
- OFF if normal.

Wiring for the 5140LED Indicator Module

Program “2” field 3*20 and connect the 5140LED Module to the J2 connector as shown in *Figure 3-25*. It is designed for mounting into a standard single-gang electrical box.

To install the 5140LED Indicator Module, perform the following steps:

Step	Action
1	Pull wires from the control panel’s J2 connector through an opening in the single-gang box and splice these wires to the modules flying leads. Solderless splices may be used.
2	Mount the module’s PC board onto one side of the PC board retainer bracket (supplied).
3	Slide the PC board retainer bracket into the box and fasten with screws (supplied).
4	Mount the stainless steel decorative cover (supplied) onto the box.

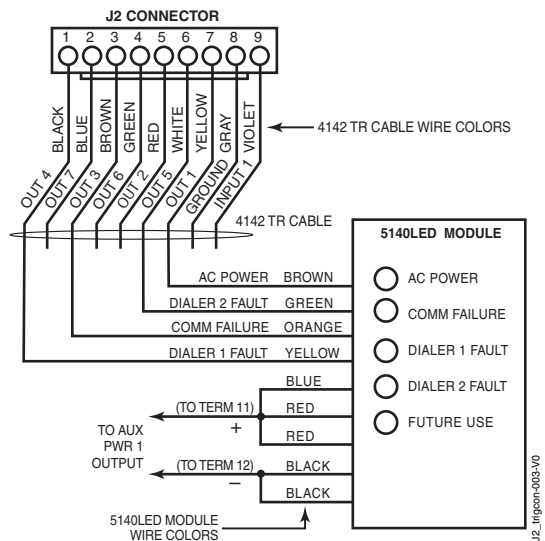

Figure 3-25: Wiring the 5140LED Indicator Module

Installing a Remote Keypad Sounder

An optional Amseco PAL 328N Piezo Sounder can be used to duplicate the sounds produced by the keypad’s built-in sounder. The remote sounder will duplicate all sounds (such as alarms, trouble beeps, etc.) except for the short beeps associated with keypad key depression. One application of this feature would be to produce chime beeps at a distant location from the keypads. If used, program field 3*20 must be set to “0” and field *15 must be set to the desired partition number.

The remote sounder must be connected to the Output 5 on the J2 connector as shown in *Figure 3-26*.

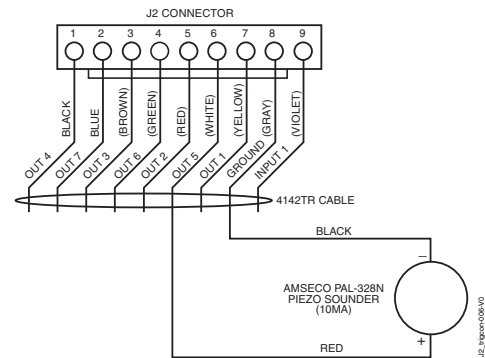

Figure 3-26: Remote Keypad Sounder Wiring

Installing the VA8200 Panel Link Module

The VA8200 Panel Link Module (PLM) connects to the keypad (ECP) terminals on the FA1700C and also connects to other PLMs via the RS-485 bus (3-wire twisted cable run). *Figure 3-27* is a block diagram of a panel linking setup using three control panels.

UL

Panel Linking is not permitted in UL installations.

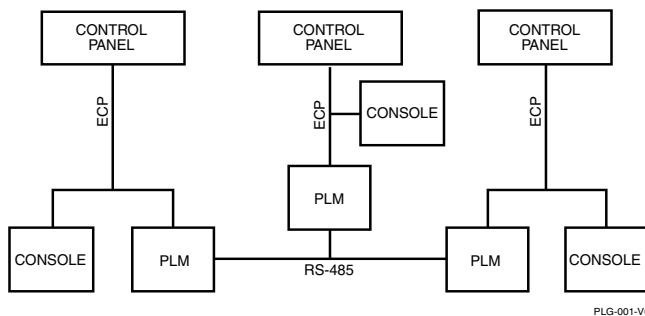

Figure 3-27: Panel Linking Block Diagram

ECP Wire Run Limitations

Determine wire gauge by referring to the table below.

Wire Run Length Table	
Wire Gauge	Length
#22 gauge	450 feet
#20 gauge	700 feet
#18 gauge	1100 feet
#16 gauge	1750 feet



- The length of the ECP wire runs combined must not exceed 2000 feet when unshielded cable is used (1000 feet if unshielded cable is run in conduit or if shielded cable is used).
- If more than one ECP device is wired to a single run, then the above maximum lengths must be divided by the number of devices on the run (e.g., the maximum length is 225 feet if two keypads are wired on a #22 gauge run).

RS-485 Bus Wire Run Limitations

The RS-485 bus from the first PLM to the last PLM cannot exceed 4000 feet, using 16-AWG twisted cable. The recommended form of wiring is to daisy chain the connection from one unit to another. If several buildings are to be connected, the RS-485 bus should form a continuous path from one building to the next. Avoid wiring units in a star configuration, where multiple branches are formed. Star configurations create loading and capacitance problems that are complex, and become difficult to troubleshoot.

Mounting and Wiring the Panel Link Module



The PLM will not operate until the device is enabled in the control's *Device Programming* in #93 Menu Mode.

To mount and wire the Panel Link Module, refer to *Figure 3-28* and perform the following steps:

Step	Action
1	Remove all power from the control panel before making any wiring connections.
2	Mount the module in the control cabinet if space is available or, adjacent to the cabinet, using 2-faced adhesive tape.
3	Set the PLM's DIP switches for a device address between 01 and 30. See the module's instructions for the DIP switch table. Do not use an address being used by another device (keypads, RF receivers, etc.).

Step	Action
4	Connect the 12V (+) and (-) and data-out and data-in connections from the PLM to the control's keypads terminals (11, 12, 13 and 14), respectively.
5	Connect the 3-wire RS-485 cable between each PLM. Recommended wiring is to bring the wires "in" from one module (or control panel) to terminals 5 (+), 6 (-), and 7 (G) and "out" to the next module from terminals TB1-8 (+), 9 (-), and 10 (G).

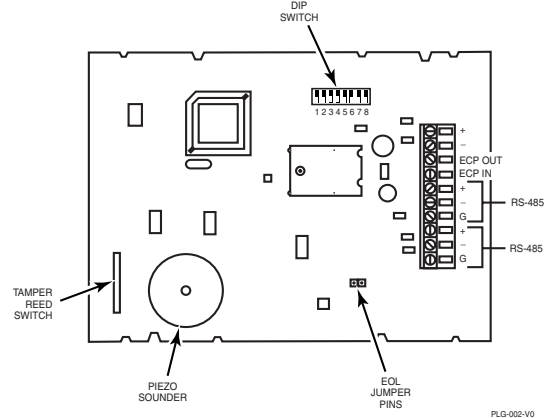

Figure 3-28: VA8200 Panel Link Module Wiring

Long Range Radio Connected to the ECP

The control can support an ECP Long Range Radio (LRR) (7820, 7835C, and 7845C are supported) that connects to control panel's keypad terminals. All messages programmed for transmission via the phone lines may also be sent via the LRR. These messages are transmitted in Contact ID format regardless of the format programmed for the control in fields 45 and 47.



We recommend that, if possible, you use Contact ID for the main dialer. If Contact ID is not used, certain types of reports are not sent.

Supervision

The data lines between the control and the LRR, as well as certain functions in the radio, can be supervised. If communication is lost or a trouble condition occurs, both the LRR and the control's dialer can be programmed to send a Trouble message to the central station.

NOTE: For complete information, see the Installation Instructions that accompany the radio.

Operation

The FA1700C features **Dynamic Signaling Delay** and **Dynamic Signaling Priority** message reporting when Long Range Radio is used. These message outputs are accessed through data fields *56 and *57, respectively. The Dynamic Signaling feature is designed to reduce the number of redundant reports sent to the central station.

The feature is described as follows:

Dynamic Signaling Delay (Field *56)

Select the time the panel should wait for acknowledgment from the first reporting destination before it attempts to send a message to the second destination. Delays can be selected from 0 to 225 seconds, in 15-second increments.

Dynamic Signaling Priority (Field *57)

Select the initial reporting destination for messages, Primary Dialer (0) or Long Range Radio (1).

The chart below provides an explanation of how the Dynamic Signaling feature functions.

If Priority (*57) is...	And message is...	Then...
Primary Phone No. ("0")	Acknowledged before delay expires	Message is removed from queue and no message is sent to LRR.
	Not acknowledged before delay expires	Message is sent to both the Primary Phone No. and LRR.
Long Range Radio ("1")	Acknowledged before delay expires	Message is removed from queue and no message is sent to Primary Phone No.
	Not acknowledged before delay expires	Message is sent to both the Primary Phone No. and LRR.

Additional LRR reporting options are defined by selecting the events for each subscriber ID in fields 58 and 59. The reporting events are Alarms, Troubles, Bypasses, Openings/Closing, System Events, and Test. Also, within an enabled category, the specific event must be enabled for dialer reporting. If, for instance, zone 10 is enabled to report, but zone 11 is not, zone 10 will report via the LRR, but Zone 11 will not.

Messages are transmitted from the FA1700C to the LRR on a "first in/first out" basis. If events occur at the same time, they are transmitted in order of priority. The priority from most to least important is: Fire Alarms, Panic Alarms, Burglary Alarms, Fire Troubles, Non-Fire Troubles, Bypasses, Openings/Closings, Test messages, and all other types of reports.

There are two subscriber IDs programmed into the LRR: primary and secondary. These correspond to the two subscriber IDs programmed into the control for each partition. If a subscriber ID for a partition is not programmed (disabling reports to that central station), the events enabled for the corresponding subscriber ID in the LRR will not be transmitted.

If the event is to be reported to both phone numbers (dual reporting), then reporting through the LRR will be done in an alternating sequence. The first event in the queue is transmitted to both the primary and the secondary radio central stations before transmitting the second event.

If split reporting is selected for the FA1700C, then the LRR will send the appropriate reports to the primary and secondary central stations.

Installing the ECP Long Range Radio

To install the LRR, perform the following steps:

Step	Action
1	Mount the radio according to the instructions that accompany the radio.
2	Connect the data in/out terminals and voltage input terminals of the radio to the control's keypad connection points, terminals 11, 12, 13 and 14. See <i>Figure 3-29</i> .

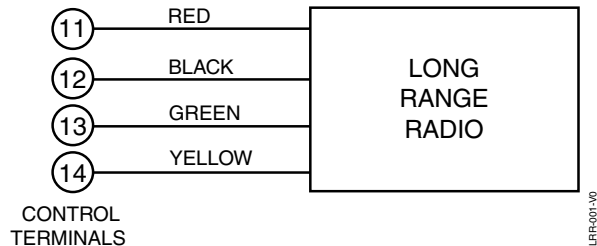

Figure 3-29: Wiring Long Range Radio to Keypad Terminals

Trouble Messages

The following messages are displayed on the FA560KP when a problem exists on the Long Range Radio:

1. "LRR Battery": The battery connected to the radio is low.
2. "PLL out of Lock": The radio has an internal fault and cannot transmit any messages.
3. "Early Power Detect": RF power is detected without a valid transmission.
4. "Power Unattained": Full RF power was never attained.
5. "Frwd. Power Loss": RF power was not sustained throughout the transmission.
6. "Antenna Fault": A problem with the antenna has been detected.
7. "LRR CRC is bad": The radio's EEPROM is corrupt (the internal CRC is bad).

NOTES:

Items 2 and 3 require factory service.

Items 4 and 5 could be the result of a bad or low battery.

If the item 6 message appears, check the antenna, connection and cable; if they are secure, factory service is required.

All these messages are displayed in conjunction with the "CHECK 8xx" message, which indicates a trouble on the address to which the LRR unit is programmed in the control.

All of these events except Antenna Fault are sent to the event log and reported to the central station using Contact ID Event Code 333 (expansion device trouble). Antenna Fault uses Event Code 357. If the tamper is tripped on the LRR, it uses Event Code 341 (expansion device tamper).

Long Range Radio Connected to the J2 Triggers

These triggers may be used to trip auxiliary alarm signaling equipment such as ADEMCO's 7720, 7720ULF, and 7920SE Long Range Radios.

The triggers are common to all partitions and must be enabled for each partition (field 2*20).



If using the Alpha Pager Module, you cannot use a Long Range Radio connected to the J2 triggers.

The fire and burglary/audible panic alarm triggers are normally LOW and go HIGH until a **User Code + OFF** is entered in all enabled partition(s) that display these conditions.

The silent panic/duress trigger latches HIGH, except for duress, which is momentary.

Refer to the installation instructions that accompany your radio for the connections to the control panel.

Installing the Alpha Pager Module

The VA8201 Alpha Pager Module (APM) is used for the transmission of alphanumeric messages to a user-subscribed Paging Service. The APM will dial and can be programmed to send the information to up to 8 different paging services. In addition, the module can direct the reports to a parallel or serial printer.

NOTE: The APM is only required for alphanumeric format. The system sends numeric format messages directly.



The Alpha Pager Module is not permitted in UL installations.

The types of events (messages) the pager can transmit are divided into 6 categories: alarms, troubles, bypasses, openings/closings, system, and test.

The options for each paging service are:

- Paging service phone number
- Format (numeric, alphanumeric)
- Two Delay Times (numeric format only): the time between dialing and transmitting of pager ID and the time between pager ID and event information
- Pager ID number (if necessary)
- Partition(s) (which partitions the events are transmitted for)
- Types of messages (events) sent). **Must be programmed for the pager to work.**

The APM hangs up between each message. Multiple messages are sent in the order received. If the APM cannot make contact with the paging service, it retries up to 10 times.



- When using the APM, field *14 must be programmed for RS232 input (1).
- The APM transmits alphanumeric messages using the TAP protocol. The installer must check with the paging service to ensure that they are using the TAP protocol Rev. 1.8 or higher.

Paging Service Advisory

If you are setting up the software for the first time, contact your paging service provider for the following two pieces of information:

- The exact access number to be used with each receiving device
- The correct PIN number for each receiving device.

Pager Formats

The system supports pager formats alphanumeric and numeric.

Alphanumeric

PP Date Time EA ZZZ SSSS AD

Where:

PP	Partition number (e.g., P1)
Date	Date the event occurred (e.g., 03/15/00)
Time	Time the event occurred (e.g., 01:16AM)
EA	Event alpha descriptor (see <i>APPENDIX D</i>)
ZZZ	Zone or user number *
SSSS	The partition's 4-digit subscriber number (in field *32)
AD	The zone's programmable alpha descriptor *

- * If the event is an arming or disarming, a 6-character descriptor can be sent for the user, if programmed, instead of the user number. The descriptor can be programmed only via the Compass Downloader.

The installer code has a default of INSTLR and user number 002 has a default of MASTER for the 6-character descriptor.

Numeric Format

SSSS P EEE ZZ, where:

SSSS	The partition's 4-digit subscriber number (field *32)
P	Partition number
EEE	3-digit event code
ZZZ	3-digit zone or user number

NOTE: If any of the digits for the subscriber number are hex digits (B, C, D, E, F), they will be replaced with 1, 2, 3, 4, 5, respectively, on the pager display.

Numeric Format Event Codes

Event	Code
Alarm	333
Trouble	555
Open	444
Close	777
Other	000

Mounting the Alpha Pager Module

The Alpha Pager Module (APM) may be mounted in the control cabinet if space is available or, if this is not possible, on the side of the cabinet or adjacent to it.



Do not mount the Alpha Pager Module on the cabinet door or attempt to attach it to the PC board.

To mount the Alpha Pager Module, perform the following steps:

Step	Action
1	If you are mounting the Alpha Pager Module inside the control cabinet, attach it to the cabinet's interior surface with 2-faced adhesive tape.
2	If you are mounting the Alpha Pager Module outside the cabinet, use the bracket interface (Ademco Part Number K5350).

Wiring the Alpha Pager Module

The Alpha Pager Module connects via the 4142TR cable to the J2 connector on the FA1700C.



- If using a serial printer, it must be configured for a baud rate of 1200, seven data bits, even parity, and one stop bit. (7/E/1).
- Automation software cannot be used if a serial printer is used on the system.

To wire the Alpha Pager Module, refer to *Figure 3-30* and perform the following steps:

Step	Action
1	Connect the 4142TR to J2 on the control.
2	Connect the Red wire of 4142TR to the Orange wire of the APM, and the Black wire of the 4142TR to the Green wire of the APM.
4	Connect the Red and Black wires of the APM to terminals 11 and 12 (auxiliary power (+) and (-), respectively) of the control.
5	Connect the APM RJ11 connectors labeled LINE and PHONE to RJ31X jacks as shown in <i>Figure 3-30</i> .
6	Connect the premises phones and the control panel phone cord as shown in <i>Figure 3-30</i> .
7	If you are using a parallel or serial printer, connect the printer according to the instructions accompanying the APM.

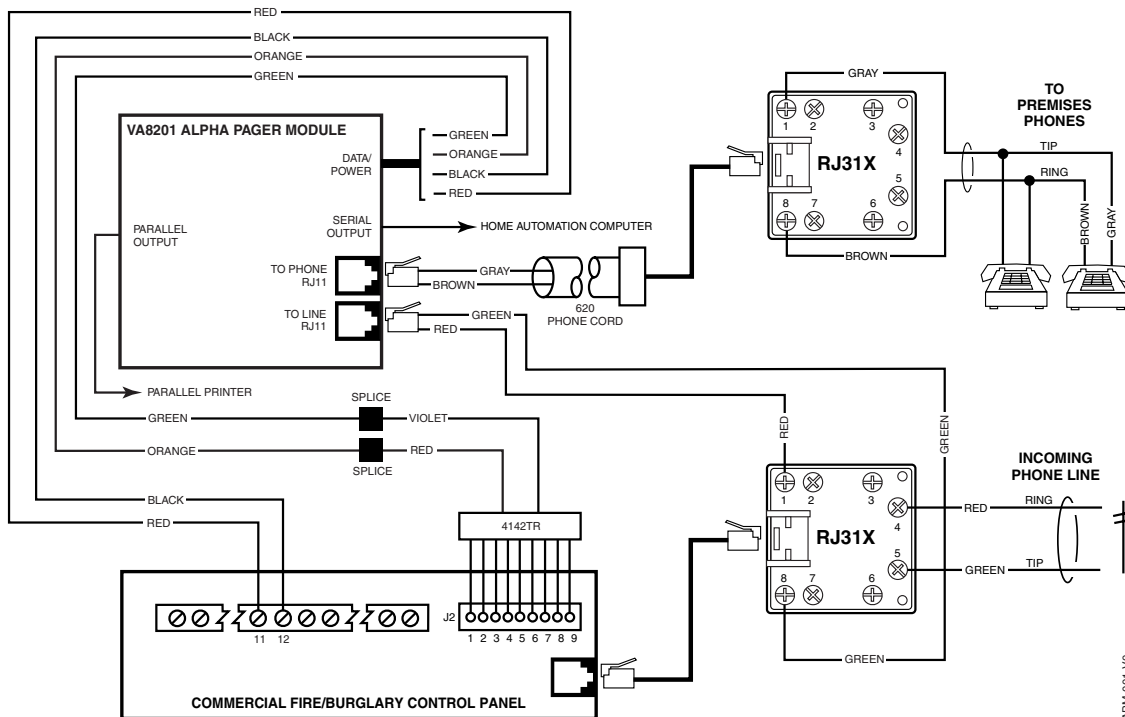

Figure 3-30: Wiring the Alpha Pager Module

Access Control Using VistaKey

The VistaKey is a single-door access control module. When connected to the alarm system, it provides access control to the protected premises. The FA1700C supports up to 15 modules (15 access points).



DO NOT USE BOTH the VistaKey and a PassPoint Access Control System on the same alarm panel.

UL

The VistaKey module contains three zones. These zones should **ONLY** be used for access control functions in UL installations. **THESE INPUT ZONES ARE NOT TO BE USED FOR FIRE AND BURGLARY APPLICATIONS IN UL INSTALLATIONS.**

VistaKey Features

- Each VistaKey communicates with the FA1700C via the V-Plex polling loop.
- If local power to the VistaKey is lost, the module provides backup monitoring of the access point door via a built-in V-Plex device that is powered solely from the polling loop. The V-Plex device is programmed in the control's Zone Programming. A serial number label is affixed to the VistaKey module for manual entry of its serial number.
- The VistaKey supports up to 500 cardholders.
- All configurable options for each VistaKey are accomplished via software, firmware, and nonvolatile memory, except the access point zone number (1-15), which is set via a user-friendly, 16-position rotary switch.
- The addition and removal of VistaKey modules from the system is easily accomplished via the FA1700C keypad.
- Each VistaKey provides one open-collector output trigger (sink 12mA @ 12VDC).

Mounting and Wiring the VistaKey



For detailed instructions on how to install and program the VistaKey, refer the *Installation and Setup Guide* that accompanies the VistaKey-SK.

To mount and wire the VistaKey module, perform the following steps:

Step	Action
1	Mount the VistaKey, door strike or mag lock, and card reader.
2	Mount the door status monitor (DSM) and/or request-to-exit (RTE) devices.
3	Using <i>Figure 3-31</i> as a reference, connect the card reader interface cable to TB3, <i>making the +5V or +12V connection last.</i>
4	Connect the leads to TB1 in the following order: <ol style="list-style-type: none"> All ground leads to terminals 2, 5, and 9. The DSM, (optional) RTE, and General Purpose leads to terminals 6, 7, and 8, respectively. Door strike (or mag lock) lead to terminal 10. Local +12V or +24V supply lead to terminal 1. Local +12V or +24V supply lead to the N/C relay terminal 11 (if a mag lock is being used), OR to the N/O relay terminal 10 (if a door strike is being used).
5	Connect the (-) polling loop and (+) polling loop leads (from the FA1700C) to terminals 4 and 3, respectively.
6	Set the Address Select switch to the desired access door number (1-15).
7	Repeat steps 1 through 6 for each VistaKey being installed.

Connecting the Card Reader

Lead from Reader	Lead Color	To VistaKey TB3 Terminal #
Green LED	Orange	1
Ground*	Black	2
DATA 1 (Clock)	White	3
DATA 0 (Data)	Green	4
+5VDC†	Red†	6
+12VDC†	Red†	7
* TB-3 Terminal 5 is also a ground and may be used instead of terminal 2. Terminals 2 and 5 are a common ground.		
† Connect to +5VDC OR +12VDC per reader manufacturer's specification.		

THIS DEVICE COMPLIES WITH PART 15 CLASS A LIMITS OF FCC RULES. OPERATION IS SUBJECT TO THE FOLLOWING TWO CONDITIONS:
 (1) IT MAY NOT CAUSE HARMFUL INTERFERENCE.
 (2) IT MUST ACCEPT ANY INTERFERENCE THAT MAY CAUSE UNDESIRABLE OPERATION.

THIS EQUIPMENT SHOULD BE INSTALLED IN ACCORDANCE WITH THE NATIONAL FIRE PROTECTION ASSOCIATION'S STANDARDS 70 & 74 (NATIONAL FIRE PROTECTION ASSOC., BATTERYMARCH PARK, QUINCY, MA. 02269). PRINTED INFORMATION DESCRIBING PROPER MAINTENANCE, EVACUATION PLANNING AND REPAIR SERVICE IS TO BE PROVIDED WITH THIS EQUIPMENT.

FOR ADDITIONAL RATINGS AND SPECIFICATIONS, REFER TO INSTALLATION INSTRUCTION FOR THE VISTAKEY-SK.

WEEKLY TESTING IS REQUIRED TO ENSURE PROPER OPERATION OF THIS SYSTEM.

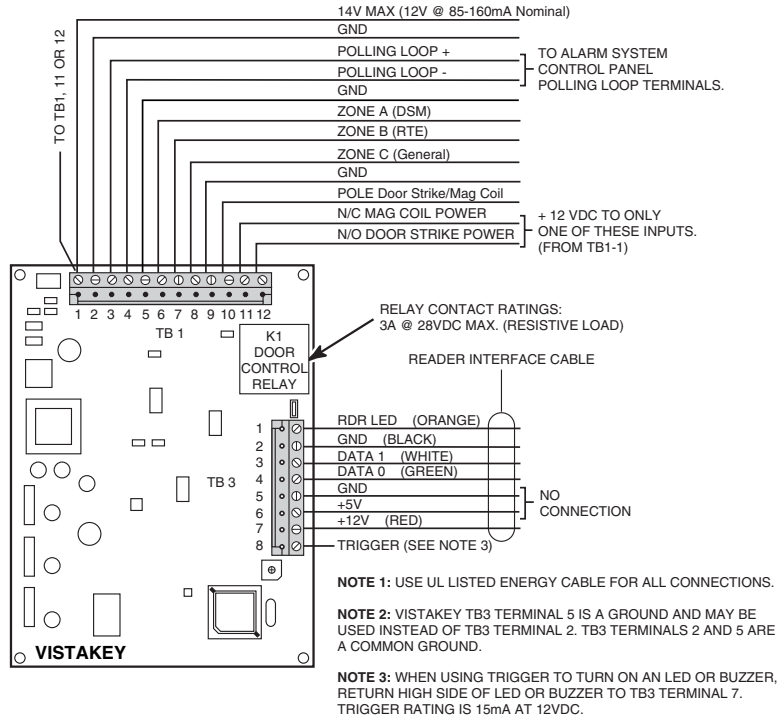

Figure 3-31: Wiring the VistaKey

Access Control Using the PassPoint Access Control System

The FA1700C interfaces with the PassPoint ACS via the VISTA Gateway Module (VGM). The VGM is connected between the ECP bus (keypad terminals) of the control and the network bus of the PassPoint ACS. The control sends the VGM its status information, event log entries, and entry/exit requests (inputs programmed with response type Access Point) from keypads, hardwired zones, and RF transmitters. The VGM then reformats and retransmits this information to the Main Logic Board, (MLB) on the PassPoint ACS network bus.

UL Interfacing the FA1700C with the PassPoint Access Control System via the VISTA Gateway Module is not permissible for UL installations.

Wiring the VISTA Gateway Module

The VISTA Gateway Module is connected between the ECP bus (FA1700C keypad terminals) and the network bus of the PassPoint Access Control System. See Figure 3-32 for the proper wiring connections.

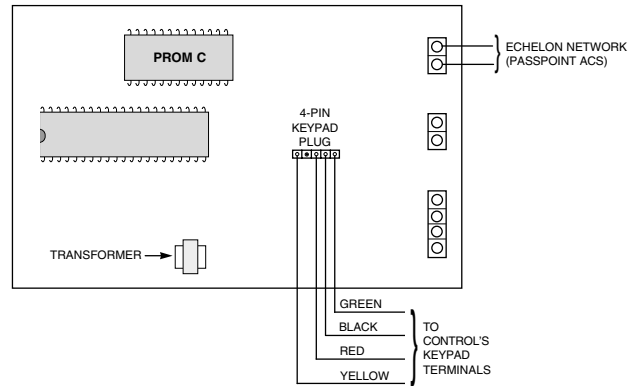

Figure 3-32: Wiring the VISTA Gateway Module

Event Log Connections

This system has the ability to record up to 1000 events of various categories in the Event Log (history log). Each event is recorded with the time and date of its occurrence (if real-time clock is set).

The categories are Alarm, Supervisory/Check, Bypass, Open/Close, System and Test conditions. The log may be viewed on an alpha keypad, the AUI or printed on a serial printer.



- When using a printer, field 3*19 must be programmed for RS232 input (1).
- If you are using a serial printer, J2 pins 5 & 9 on the control panel cannot be used to interface with Automation software.

Using the Alpha Pager Module (APM)

To connect a printer using the Alpha Pager Module, perform the following steps:

Step	Action
1	Connect the APM to the control (see <i>Installing the Alpha Pager Module</i> previously in this section).
2	Connect the printer according to the instructions that accompany the APM.

Using the 4100SM

To connect a serial printer using the 4100SM, refer to *Figure 3-33* and perform the following steps:

Step	Action
1	Connect the 4142TR cable to J2 on the control.
2	Connect the Violet and Red wires of the 4142TR to terminal 1 and 6 on the 4100SM, respectively.
3	Connect terminals 8 and 7 of the 4100SM to terminals 11 and 12 (aux. power (+) and (-)), respectively of the control.
4	Connect the serial printer to the 4100SM. NOTE: The 4100SM Module is supplied with a 10-foot RS232 cable. A longer cable can be used if the FA1700C is separated from the serial printer by more than 10 feet, but the total cable length should be less than 50 feet.

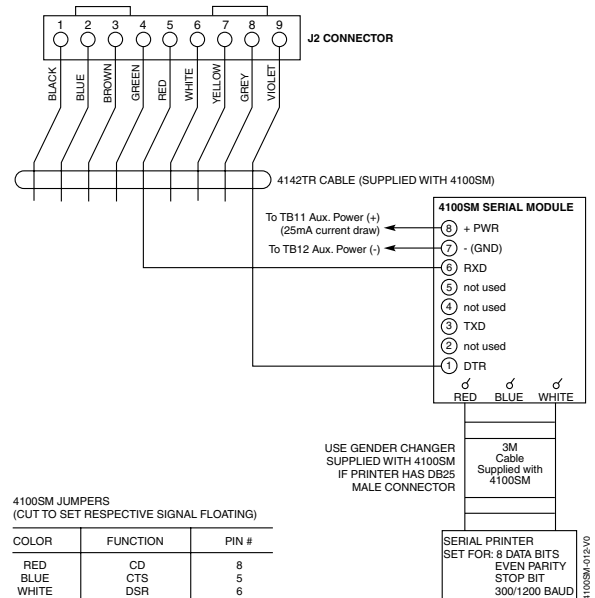

Figure 3-33: Printer Connections to the 4100SM

NOTE: See the 4100SM Installation Instructions for details concerning the serial printer operation.

NOTES:

- If you are using printer, field 3*19 must = 1.
- If you are using a serial printer, it must configured with 7 data bits, even parity, 1 stop bit, 1200 baud

Installing the 4285/4286 VIP Module

The 4285/4286 VIP Module is an add-on accessory that permits the user to access the security system (and relays) via a TouchTone telephone. This may be done either from the premises or by calling the premises from a remote location. Only one VIP Module can be used in a security system. This module must be enabled as Device Address 4 in the *Device Programming* in #93 Menu Mode, and must be assigned to a partition.

UL The 4285/4286 VIP Module is not permitted in UL installations.

Detailed operating instructions for phone access to the security system are provided with the VIP Module.

The 4285/4286 VIP Module features:

- Allows the user to receive synthesized voice messages over the phone regarding the status of the security system.
- Allows the user to arm and disarm the security system and perform most other commands using the telephone keypad.

- Allows the user to control relays using the telephone keypad.
- Provides voice annunciation over the phone to confirm any command that is entered.
- Announces many of the same words that would normally be displayed on an alpha keypad under the same system conditions. Refer to the words in bold on the Alpha Vocabulary list found in the #93 Menu Mode Programming in the *Programming Guide*.
- Can be supervised for connection to control panel (annunciated and reported as Zone 804).

The 4285/4286 is wired between the control panel and the premises' handset(s) (see *Figure 3-34*). It listens for TouchTones on the phone line and reports them to the control panel. During on-premises phone access, it powers the premises phones; during off-premises phone access, it seizes the line from the premises phones and any answering machines.



- The VIP module will not operate until the device address (04) is enabled in the control's *Device Programming in #93 Menu Mode*.
- Do not mount the VIP Module on the cabinet door or attempt to attach it to the PC board.

To install the VIP module, perform the following steps:

Step	Action
1	Mount the module in the control cabinet if space is available or, if this is not possible, on the side of the cabinet or adjacent to it. If you mount the VIP Module inside the control cabinet , attach it to the cabinet's interior surface with 2-faced adhesive tape. You may leave the module's cover off if it is mounted within the cabinet. If you mount the module outside the cabinet , use the screw holes at the rear to mount horizontally or vertically (2-faced adhesive tape may be used, if preferred).
2	Affix the 4285/4286 connections label (supplied separately) to the inside of the VIP Module's cover, if the cover is used. Otherwise, affix the label to the inside of the control cabinet's door.
3	Make 12V (+) and (-) and data-in and data-out connections from the VIP Module to the control, using the connector cable supplied with the VIP Module. These are the same connections as for remote keypads.

Step	Action																
4	Connect the module to the phone line as shown below. See <i>Figure 3-34</i> . <table border="1" style="margin-top: 10px;"> <thead> <tr> <th>4285/4286 Terminal</th> <th>Connects to:</th> </tr> </thead> <tbody> <tr> <td>1. Phone In (Tip)</td> <td>green wire of direct-connect cord</td> </tr> <tr> <td>2. Phone In (Ring)</td> <td>red wire of direct-connect cord</td> </tr> <tr> <td>3. Phone Out (Tip)</td> <td>brown wire of direct-connect cord</td> </tr> <tr> <td>4. Phone Out (Ring)</td> <td>gray wire of direct-connect cord</td> </tr> <tr> <td>5. No Connection</td> <td></td> </tr> <tr> <td>6. Audio Out 1*</td> <td>Speaker</td> </tr> <tr> <td>7. Audio Out 1*</td> <td>Speaker</td> </tr> </tbody> </table> <p>*Supported by the 4286 only</p> <p>Use an RJ31X Jack with the phone cable supplied with the control to make connections to the VIP module. Make connections exactly as shown in <i>Figure 3-34</i>. This is essential, even if the system is not connected to a central station. The 4285/4286 will not function if this is not done.</p>	4285/4286 Terminal	Connects to:	1. Phone In (Tip)	green wire of direct-connect cord	2. Phone In (Ring)	red wire of direct-connect cord	3. Phone Out (Tip)	brown wire of direct-connect cord	4. Phone Out (Ring)	gray wire of direct-connect cord	5. No Connection		6. Audio Out 1*	Speaker	7. Audio Out 1*	Speaker
4285/4286 Terminal	Connects to:																
1. Phone In (Tip)	green wire of direct-connect cord																
2. Phone In (Ring)	red wire of direct-connect cord																
3. Phone Out (Tip)	brown wire of direct-connect cord																
4. Phone Out (Ring)	gray wire of direct-connect cord																
5. No Connection																	
6. Audio Out 1*	Speaker																
7. Audio Out 1*	Speaker																



- If touch-tones are not present following phone access to the security system *via an on-premises phone*, try reversing the pair of wires connected to terminals 3 and 4 on the 4285/4286.
- If the phone plug is disconnected from the control, the premise's phones will not operate.

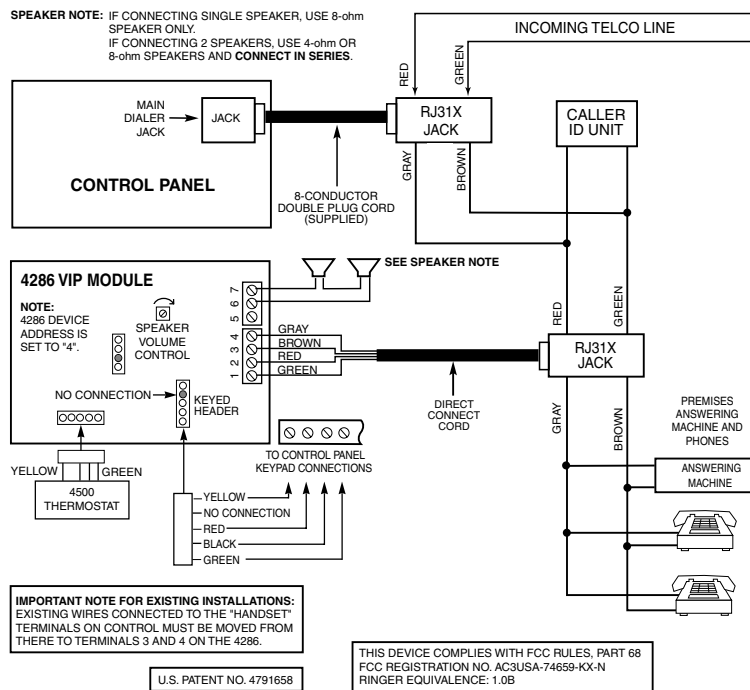

Figure 3-34: 4285/4286 VIP Module Connections

Installing the Audio Alarm Verification Module

UL

Audio Alarm Verification (AAV) is not permitted in UL installations.



- 685 Receiver software must be rev. 4.6 or higher. Earlier versions will not hold the phone line connection.
- Contact ID code for "Listen-in to Follow" is 606. Contact ID is the only reporting format that will send a "Listen-in to Follow."

NOTES:

- When the AAV indicates that the audio alarm verification session is completed, all keypad sounds are restored. Sirens are restored if the alarm timeout period has not expired.
- As part of its fail-safe software, the control limits all audio alarm verification sessions to 15 minutes. This is because once the session begins, the AAV Module controls the duration.
- If a new **Fire alarm** should occur during a session, the control breaks the phone connection and sends the new Fire Alarm report, then re-triggers the AAV Mode. All other dialer messages triggered during ongoing conversation are held until either the AAV Module signals that it is inactive, or the 15-minute timeout occurs.



If the phone plug is disconnected from the control, the premise's phones will not operate.

To install the Eagle 1250 AAV module to the control, perform the following steps:

Step	Action
1	Mount the module in the control cabinet if space is available or, if this is not possible, on the side of the cabinet or adjacent to it.
2	Connect the Eagle 1250 Module terminals 7 and 8 to the control's zone 5 terminals 22 and 23. The purpose of this connection is to silence and restore the sounders at the premises. It is also used to postpone noncritical dialer reports while the AAV session is in progress.
3	Program zone 5 with a response type (e.g., 10 Interior w/Delay). Field 1*60 must be enabled to silence sounders on the premises. Zone 5 is no longer available as a protection zone.
4	Connect the AAV module's falling-edge trigger input (terminal 5 on Eagle model 1250) to a 4204 relay module, as shown in Figure 3-35. Program the start and stop system operation as 60 for the 4204 relay, in <i>Output Programming</i> in the #93 Menu Mode.

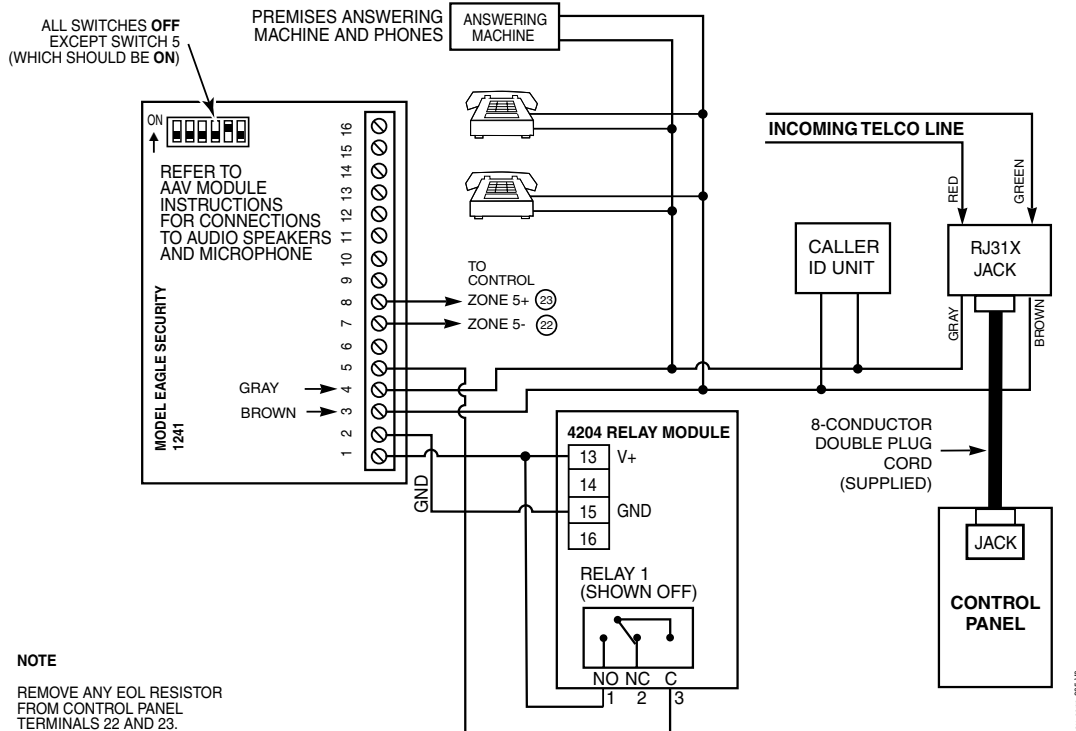

Figure 3-35: AAV Connections

Connecting the Transformer

Use the 1451 Transformer with enclosure (supplied) with the FA1700C control when the PS24 Power Supply will not be used. This transformer provides 18VAC/72VA secondary winding for powering the control.

Use the 1451-24 Transformer when using both the FA1700C and the PS24 Power Supply. This transformer provides 18VAC/72VA secondary winding to power the control and 30VAC/188VA secondary winding to power the PS24 Power Supply.

The control panel kit you purchased comes with the appropriate transformer. Both transformers have a manually resettable circuit breaker mounted inside a protective metal enclosure.

Use the following instructions for mounting and wiring the 18VAC secondary winding of either transformer. Use the instructions provided with the PS24 Power Supply Module to wire the 30VAC winding of the 1451-24 Transformer.

To connect the 1451 transformer to the control, perform the following steps:

Step	Action
1	Remove the front cover of the enclosure.
2	Mount the enclosure to the wall near the FA1700C control panel. The enclosure has 4 mounting holes on its back surface for this purpose.
3	Run 120VAC wiring to the enclosure in conduit. A dedicated circuit must be used.

Step	Action
4	Use wire nuts to splice the 120VAC wires to the transformer's white and black primary leads.
5	Connect the earth ground post on the back of the enclosure to a good earth ground.
6	Run 16AWG wire in conduit from the enclosure to the control panel.
7	Use wire nuts to splice the transformer blue 18VAC secondary leads to the 16AWG wire. Connect the 16AWG wire at the control panel to terminals 1 and 2.
8	Replace the front cover of the enclosure and fasten it with the screws supplied



- Use wires having insulation rated for at least 90°C operation and suitable for non-power limited applications.
- Use care to keep 18VAC wiring separated from all other wiring inside the control panel's enclosure. This must be done by running non-power-limited 18VAC wiring into the control panel's enclosure via one of the knockouts on the left-hand side, and then tie-wrapping these wires to the tie-wrap loops located near the knockout.

Earth Ground Connections

In order for the lightning transient protective devices in this product to be effective, the designated earth ground terminal (terminal 30) must be terminated in a good earth ground. Recommended wire gauge for the ground connection is #16 AWG, run no farther than 30 feet.



The panel requires the earth ground connection for its lightning transient protection devices.

To connect the earth ground, perform the following steps:

Step	Action
1	Connect the earth ground post inside the 1451 enclosure to a good earth ground (use grounding methods specified in the National Electric Code).
2	Use a green nut (supplied) to secure the wire to the ground post. The ground wire should be the only wire under this nut.
3	Run a 16AWG wire from the ground post to the panel's earth ground terminal (30). Use a second green nut (supplied) to secure this wire to the ground post. This connection avoids ground loops that may occur when the 1451 and panel are connected to different earth ground systems.

Determining the Control's Power Supply Load

In the event of an AC power loss the FA1700C and the PS24 Power Supply Module must be supported by backup, rechargeable batteries. When the system is used **without** the PS24, a 12VDC, 12AH to 34.4AH battery must be connected the control panel. When the system is used **with** a PS24, two 12VDC, 7AH to 17.2AH batteries must be connected to the PS24.

The PS24 configures these batteries to provide 24V backup power to its outputs and 12V backup power to the control panel.

The battery's capacity must be sized to provide 24 hours (UL central station fire) or 60 hours (UL remote station fire) of standby time followed by 5 minutes (fire only) or 15 minutes (fire and burglary) alarm time.

Use the worksheets that follow to calculate the total current for Auxiliary Power 1, Auxiliary Power 2, Bell 1, Bell 2, Polling Loop and the total current load of the control panel. In each worksheet, multiply each device's standby and/or alarm current by the number of units used.

Then, **if you are using the PS24**, fill out the Total PS24 Module Load Worksheet, found in the PS24's instructions, to determine the required capacity of the backup batteries that must be connected to the PS24. Select two batteries from the Battery Selection Table in the PS24's instructions that have a capacity greater than or equal to the calculated capacity.

If you are NOT using the PS24, fill out the Battery Capacity Calculation Worksheet, following the other worksheets below, to determine the required capacity for the backup battery. Select a battery from the Battery Selection Table (found later in this section) that have a capacity greater than or equal to the calculated capacity.

1. In Worksheet 1, enter devices used on the polling loop. Calculate total current draw on the polling loop.

Worksheet 1: Total Polling Loop Current Draw

Polling Loop Device	Current	# of Units	Total
Polling Loop Subtotal (terminals 28 & 29 – 128mA) *			

*The total current cannot exceed 128mA. If total load exceeds 128mA, then 4297 Loop Extender Modules can be used. This module is powered from the panel's auxiliary power, and provides a separate polling loop output. Each module can support an additional 128mA load. Note that the total number of points connected to the panel cannot exceed 242.

2. In Worksheet 2, enter devices used on Auxiliary Power 1. Calculate standby and alarm currents, then add to get Auxiliary Power 1 current subtotal.

Worksheet 2: Auxiliary Power 1 Current Load

Device Model #	Device Current X # of Units	Total Current	
		Standby	Alarm
Auxiliary Power 1 Subtotal (terminals 10 & 11)		1A max.	1.7A max.

3. In Worksheet 3, enter devices used on Auxiliary Power 2. Calculate standby and alarm currents, then add to get Auxiliary Power 2 current subtotal.

Worksheet 3: Auxiliary Power 2 Current Load

Device Model #	Device Current X # of Units	Total Current	
		Standby	Alarm
Auxiliary Power 2 Subtotal (pin 5 on keypad port 2)		400mA max.	1.7A max.

4. In Worksheet 4, enter devices connected to the Bell 1 Output. Calculate alarm currents, then add to get the Bell 1 Output current subtotal.

Worksheet 4: Bell 1 Output Current Load

Device Model #	Device Current X # of Units	Total Current	
		Standby	Alarm
		XXXXXX	
		XXXXXX	
		XXXXXX	
		XXXXXX	
		XXXXXX	
		XXXXXX	
		XXXXXX	
Bell 1 Output Subtotal (terminals 3 & 4 – 1.7A max.)			

5. In Worksheet 5, enter devices connected to the Bell 2 Output. Calculate alarm currents, then add to get the Bell 2 Output current subtotal.

Worksheet 5: Bell 2 Output Current Load

Device Model #	Device Current X # of Units	Total Current	
		Standby	Alarm
		XXXXXX	
		XXXXXX	
		XXXXXX	
		XXXXXX	
		XXXXXX	
		XXXXXX	
Bell 2 Output Subtotal (terminals 5 & 6 – 1.7A max.)			

6. In Worksheet 6, enter the total calculated subtotals of all listed outputs from Worksheets 1 through 5, then add to get the combined current.

Worksheet 6: Total FA1700C Current Load

	Total Current	
	Standby	Alarm
Polling Loop Subtotal		
Auxiliary Power 1 Subtotal		
Auxiliary Power 2 Subtotal		
Bell 1 Output Subtotal		
Bell 2 Output Subtotal		
FA1700C PCB Current (Including 2-wire smoke detector loading on zones 1 & 2)	300mA	470mA
5140DLM Backup Dialer Module	5mA (inactive)	15mA (active)
Total Current Load (1A max. standby; 2.3A max. alarm)		

NOTE: The 5140DLM actually draws 55mA when active. However, since the control panel PCB current includes the main dialer current, and since the main dialer is inactive when the 5140DLM is active, the 5140DLM imposes only a 15mA added load on the current supply.



- **If you are not using the PS24**, the total control standby load must be limited to 1.27A for 24-hour standby time, or to 510mA for 60-hour standby time using a 12V, 34.4AH battery connected to the control.
- **If you are using the PS24**, skip the Battery Capacity Calculation Worksheet that follows and fill out the worksheets found the PS24's instructions instead. The total control panel standby load must be limited to 919mA for 24-hour standby time or 345mA for 60-hour standby time using two 12V, 17.2AH batteries connected the PS24.

Determining the Size of the Standby Battery

For burglary installations requiring 4-hour standby time followed by 15-minutes alarm time, use a 12AH battery to support all loads up to and including the maximum system load (e.g., 1.3A standby/2.8A alarm total control panel load). For fire installations requiring 24-hour or 60-hour standby time, use the worksheet below to calculate the required battery capacity.



DO NOT use Gates batteries (sealed lead-acid type). These batteries require a different charging voltage than is supplied by the panel.

Use Worksheet 7 to determine the required backup battery capacity and use The Battery Selection Table to determine the battery model number. **A dual battery harness is supplied** that allows two batteries to be wired in parallel for increased capacity.

7. Using the total calculated from Worksheet 6, calculate the battery capacity required for the installation.

Worksheet 7: Battery Capacity Calculation Worksheet

Capacity	Formula	Calculated Value
Standby Capacity	Total standby current X 24 or 60 hours X 1.1 contingency factor.	
Alarm Capacity	Total alarm curr. X 0.083 (5 min) or X 0.250 (15 min)	
Total Capacity	Add standby and alarm capacities	

NOTE: WHEN CONNECTING BATTERIES IN PARALLEL:
 - USE BATTERIES FROM THE SAME MANUFACTURER AND WITH THE SAME VOLTAGE AND CAPACITY RATING.
 - USE BATTERIES WITH APPROXIMATELY SAME AGE AND STATE OF CHARGE.
 - USE CABLES PROVIDED AND **OBSERVE POLARITY!**
 - IT IS RECOMMENDED THAT ALL BATTERIES BE REPLACED AT SAME TIME, EVEN IF ONLY ONE BATTERY HAS BECOME WEAK.
 - AS LONG AS ONE GOOD BATTERY REMAINS CONNECTED, THE ONCE PER 60 SECOND BATTERY TEST WILL NOT DETECT THE DISCONNECTION OF REMAINING BATTERIES.

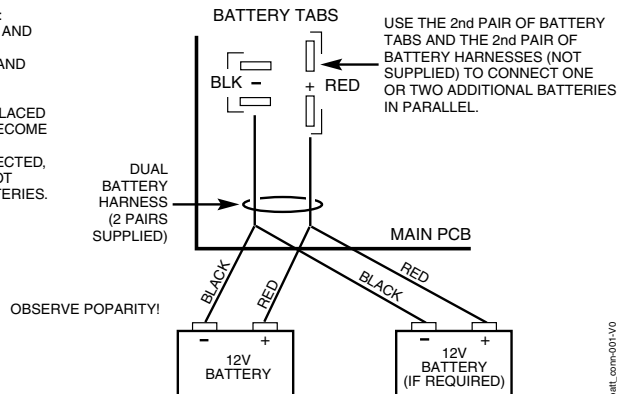

8. Use the Battery Selection Table to select the appropriate battery for the installation.

Battery Selection Table

Capacity	Recommended Battery	Comment
4AH	Yuasa NP4-12	
7AH	Yuasa NP7-12	
12AH	Yuasa NP12-12	Fits in large mercantile cabinet only.
14AH	Yuasa NP7-12	Connect two in parallel.
17.2AH	Yuasa NPG18-12	Fits in large mercantile cabinet only.

9. Connect the battery, referring to *Figure 3-36*.



The standby battery is automatically tested for 10 minutes every 4 hours, beginning 4 hours after exiting Programming mode. In addition, entry into the Test mode initiates a battery test. The FA1700C also runs a 5-second battery test every 60 seconds to check if the battery is connected.

Figure 3-36: Connecting the Backup Batteries

Programming

Program Modes

There are two programming modes for the FA1700C. These are the Data Field Program Mode and the #93 Menu Mode. The Data Field Program Mode is where many system options are programmed. The #93 Menu Mode is an interactive mode that require a 2-line alpha keypad (FA560KP).



The factory-loaded defaults (*97) enable keypad addresses 00-01 only. A keypad set to one of these addresses must be used to program the system initially.



Local keypad programming can be disabled through Compass downloading software. If this is done, Program mode can only be accessed via the downloading software.

Entering and Exiting Programming Mode

Enter Programming mode using either method a or b:

- a. Press both the [*] and [#] keys at the same time within 30 seconds after power is applied to the control.
- b. Enter the **Installer Code + [8] + [0] + [0] + [0]** keys. The factory installer code can be changed once in the Program mode (field *00).

NOTE: The default for the Installer Code is 5140.

Exit the Programming mode by either method a or b:

- a. Press [*] + [9] + [8]. Exiting by this method prevents the installer code from being used to re-enter Programming mode. Only method “a” can be used to re-enter Programming mode.
- b. Press [*] + [9] + [9]. Exiting by this method permits the installer code to be being used to re-enter Programming mode.

Data Field Programming Mode

In the Data Field Program Mode you may access any field simply by entering either [*] or [#] + the field number:

- To write or change information in a field press [*] + the field number (*03).
- To read the information in a field press [#] + the field number (#03).

When the entries for a field are completed, the keypad beeps three times and advances to the next field.

SUMMARY OF DATA FIELD PROGRAMMING COMMANDS

*91	Select partition for programming partition-specific fields
*92	Display the software revision level of the control panel
*93	Enter Menu mode programming
*94	Go to next page of fields
*99	Go back to previous page of fields or exit Programming Mode with no installer code lockout
*98	Exit Programming Mode with Installer Code lockout

Moving from One Page of Programming to Another

The data fields are grouped into three levels (referred to as “pages”). The first page is accessed as soon as Programming Mode is entered.

The second and third pages of data fields are indicated at the keypad by a 1 and 2, respectively, in front of the 2-digit field address. “ALT PROGRAM MODE” is displayed along with a “100”, “200” or “300,” indicating which page of program fields is accessed.

To access the next level of programming fields:

- 1 Press *94.
- 2 Press [*] + [XX], where XX = the last two digits of the program field, and make the desired entry.

NOTES:

Press *94 to move to 2nd page, (fields 1*01 - 1*76); press *99 to move back to 1st page.

Press *94 to move to 3rd page (fields 2*00 - 2*88); press *99 to move back to 2nd page.

Press *94 to move to 4th page, (fields 3*00 - 3*85); press *99 to move back to 3rd page.

Entry Errors

- If an address is improperly entered, the keypad displays “FC.”
- If a program entry is improperly entered (for example, a larger number than is permitted), the keypad display will go blank.

In either of the above cases, simply re-enter [*] + the correct field number and then enter the correct data.

Programming System-Wide Data Fields

Values for some programming fields are system-wide (global), and some can be different for each partition (partition-specific).



The partition-specific programming fields are automatically skipped when programming the global fields. If the system has only 1 partition, the partition-specific fields *are not* automatically skipped.

To program system-wide data fields, perform the following steps:

Step	Action
1	Enter Program Mode: Installer Code + 8 0 0 0 . The following display appears: <div style="border: 1px solid black; padding: 5px; width: fit-content; margin: 5px 0;">Program Mode *Fill # View – 00</div>
2	If the control has not been programmed before, enter *97 to load factory defaults.
3	Press [*] and enter the first field number to be programmed (for example, *00, Installers Code). Make the desired entry. When the field is complete, the keypad beeps three times and advances to the next field. If you do not want to change the next field, press [*] and enter the next field number to be programmed. <div style="border: 1px solid black; padding: 5px; width: fit-content; margin: 5px 0;">First Page of fields (*00 - *90)</div> To move to the next page of fields, press *94. To return to the previous page, press *99.
4	Press *99 or *98 to exit Program Mode.

NOTE: If the number of digits that you enter in a data field is fewer than the maximum permitted (for example, a phone number), the keypad displays the last entry and waits. To proceed, enter [*] + the next data field you wish to program.

Programming Partition-Specific Data Fields

To program partition-specific data fields once in Program Mode, do the following:

Step	Action
1	Enter Program Mode: Installer Code + 8 0 0 0 .
2	Press *91, which will prompt you for the partition number desired.
3	Enter a partition-specific field number (e.g., *09) to begin programming. When the first field’s entry is completed, the next partition-specific field is automatically displayed. When all partition-specific fields are programmed, the system returns to the global programming fields (page 1 fields).
4	Repeat this procedure for each partition in the installation.

NOTE: To return to the global program fields before finishing all fields, enter any global field number.

Programming Partition-Specific Fields

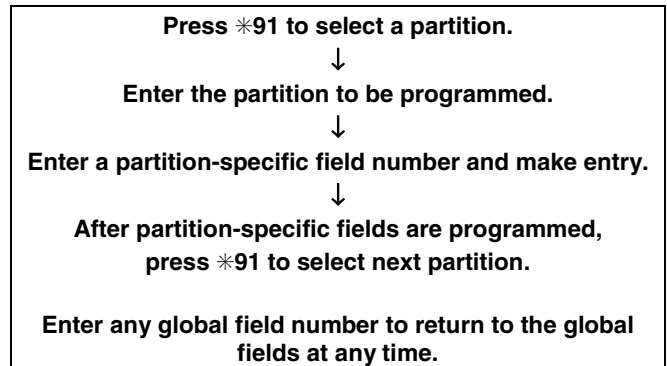

#93 Menu Mode Programming

The #93 Menu Mode is an interactive mode through which much of the system’s programming is done. In this mode, there are “question and answer” prompts that can be accessed once Data Field Program Mode has been entered. These prompts require a 2-line alpha keypad (FA560KP).

After programming all system-related programming fields in the usual way, press #93 while still in programming mode to display the first choice of the menu-driven programming functions. Press 0 (NO) or 1 (YES) in response to the displayed menu selection. Pressing 0 will display the next choice in sequence.

Below are the main menu selections. For details refer to the *FA1700C Programming Guide*.

MAIN MENU	OPTIONS
ZONE PROG? 1 = YES 0 = NO 0	For programming the following: <ul style="list-style-type: none"> • Zone Number • Zone Response Type • Partition Number for Zone • Dialer report code for zone • Input Device Type for zone (whether RF, polling loop, etc.) • Enrolling serial numbers of 5800 Series transmitters & serial polling loop devices into the system. • Zone Attributes (e.g., Arm w/Fault, Silent, etc.).
EXPERT MODE? 1 = YES 0 = NO 0	Same as Zone Programming except: <ul style="list-style-type: none"> • Done with a minimum number of keystrokes. • Can program wireless keys using pre-defined templates. <p>NOTE: All the zone attributes cannot be programmed using the Expert Mode.</p>
REPORT CODE PROG? 1 = YES 0 = NO 0	For programming the following: <ul style="list-style-type: none"> • Alarm report codes for zones • Restore and supervisory codes • All other system report codes
ALPHA PROG? 1 = YES 0 = NO 0	For entering alpha descriptors for the following: <ul style="list-style-type: none"> • Zone Descriptors • Installer's Message • Custom Words • Partition Descriptors • Relay Descriptors
DEVICE PROG? 1 = YES 0 = NO 0	For defining the following device characteristics for addressable devices, including keypads, RF receivers (5881), output relay modules (4204/4204CF), FSA (FSA-8/FSA-24), 4285/4286 VIP Module, Panel Link Module (VA8201), ECP long range radio (7845C), and VISTA Gateway Module: <ul style="list-style-type: none"> • Device Address • Device Type • Keypad Options (including Partition assignment) • RF House ID • LRR Options (including Programming radio)
OUTPUT PGM? 1 = YES 0 = NO 0	For defining output device functions.
RLY VOICE DESCR? 1 = YES 0 = NO 0	For entering voice descriptors for relays to be used with the 4285/4286 VIP Module.
CUSTOM INDEX ? 1 = YES 0 = NO 0	For creating custom word substitutes for VIP Module annunciation.
ACCESS POINT PGM 1 = YES 0 = NO 0	For defining the parameters for each of the VistaKey zones, including which group(s) have access through an access point (door). See the <i>VistaKey-SK Installation and Setup Guide</i> for detailed programming instructions.
ACCESS GRP PGM 1 = YES 0 = NO 0	For defining the capabilities (privileges) for each group of users. See the <i>VistaKey-SK Installation and Setup Guide</i> for detailed programming instructions.
EVENT/ACTION PGM 1 = YES 0 = NO 0	For defining events and time windows for an access group. See the <i>VistaKey-SK Installation and Setup Guide</i> for detailed programming instructions.

MAIN MENU	OPTIONS
------------------	----------------

SCHEDULED CHK-IN 1 = YES 0 = NO 0	For defining the schedule for the system to automatically call the downloader.
---	--

Following is a list of commands used while in the Menu Mode:

#93 Menu Mode Programming Commands

#93	Enters Menu Mode.
[*]	Serves as [ENTER] key. Press to have keypad accept entry.
[#]	Backs up to previous screen.
0	Press to answer NO.
1	Press to answer YES.
00, or 000+[*]	Quits Menu Mode and goes back to Data Field Programming Mode, if entered at first prompt of each main menu option.

Zone Number Designations

The FA1700C supports up to 250 zones, of hardwire, polling loop and/or wireless protection, distributed among up to 8 partitions. The following table lists the zone numbers and the types of sensors that can be used with each, and some alternate functions of the zones.

Zone	Function
1 & 2	2-wire Smoke Detectors (if used)
5	Audio Alarm Verification (if used)
6	Cabinet Tamper/Ground Fault (if used)
7	Keyswitch (if used)
8	Latching-Type Glassbreak Detectors (if used)
1-8	Traditional Hardwired Zones
1-250	5800 Series Wireless Devices
9-250	Polling Loop Devices
995	* + 1 Panic
996	# + 3 Panic
999	* + # Panic

Zone Defaults

Zone #	Zone Type	Zone #	Zone Type
001	09	800-830	00
002	03	970	00
003	03	971-974	19
004**	04	975	00
005	03	988 & 990	00
006	03	992*	N/A
007	03	995	00
008	03	996	00
010-250	00	997	19
601-632	00	999	06

NOTES:

- * Zone 992 is the Duress zone. Programming of the zone response type is not applicable. This zone requires only the report code programming.
- ** Zone 004 is also defaulted with Auto-STAY enabled.

Zone Index

The zones are designated as follows:

ZONE # RANGE	ZONE FUNCTION	ACTUAL ZONE
001 – 250	Protection zones	As indicated
601 – 632	Relay Supervisory Zones	6 + 2-digit Relay Number; e.g., Relay Number 03, if supervised, is zone 603.
800 – 830	ECP Device Supervisory Zones	8 + 2-digit Device Address; e.g., Device Address 01, if supervised, is zone 801. 4285/4286 VIP Module is zone 804 (because its Device Address must be set to 4).
970-977, 988, 990, & 997	System Supervisory Zones	970: Bell 1 Output 971: Bell 2 Output 972: Earth Ground 973: J2 Input 1 (LRR) 974: Dialer 1 975: Dialer 2 976: Auxiliary Relay 977: J2 LRR Trigger Outputs 988: 2 nd Wireless Receiver – not receiving signals 990: 1 st Wireless Receiver – not receiving signals 997: Polling Loop (short circuit)
992, 995 – 999	Duress and Keypad Panics	992: Duress 995: 1 + * panic (A key) 996: 3 + # panic (C key) 999: * + # panic (B key)

Supervisory zones should be given a response type of either 05 (Trouble by Day, Alarm by Night) or 19 (24-Hour Trouble).

Communication Defaults

- *45 PRIMARY FORMAT [1] ADEMCO Contact ID
- *46 LOW SPEED FORMAT (Prim) [0] ADEMCO Low Speed
- *47 SECONDARY FORMAT [1] ADEMCO Contact ID
- *48 LOW SPEED FORMAT (Sec.) [0] ADEMCO Low Speed
- *49 CHECKSUM VERIFICATION [0] [0]
No checksum Primary Secondary
- *50 SESCOA/RADIONICS SEL. [0] Radionics
- *51 DUAL REPORTING [0] no
- *52 STANDARD/EXPANDED REPORT FOR PRIMARY
[0] [0] [0] [0] [0] [0] standard
Alarm Rstr Bypass Trbl Opn/Cls Low Bat
- *53 STANDARD/EXPANDED REPORT FOR SECONDARY
[0] [0] [0] [0] [0] [0] standard
Alarm Rstr Bypass Trbl Opn/Cls Low Bat

Communication Defaults for Zones

ZONE #	1st	2nd	ZONE #	1st	2nd	ZONE #	1st	2nd	ZONE #	1st	2nd
1	01	00	54	09	00	107	02	00	160	10	00
2	02	00	55	10	00	108	03	00	161	11	00
3	03	00	56	11	00	109	04	00	162	12	00
4	04	00	57	12	00	110	05	00	163	13	00
5	05	00	58	13	00	111	06	00	164	14	00
6	06	00	59	14	00	112	07	00	165	15	00
7	07	00	60	15	00	113	08	00	166	01	00
8	08	00	61	01	00	114	09	00	167	02	00
9	09	00	62	02	00	115	10	00	168	03	00
10	10	00	63	03	00	116	11	00	169	04	00
11	11	00	64	04	00	117	12	00	170	05	00
12	12	00	65	05	00	118	13	00	171	06	00
13	13	00	66	06	00	119	14	00	172	07	00
14	14	00	67	07	00	120	15	00	173	08	00
15	15	00	68	08	00	121	01	00	174	09	00
16	01	00	69	09	00	122	02	00	175	10	00
17	02	00	70	10	00	123	03	00	176	11	00
18	03	00	71	11	00	124	04	00	177	12	00
19	04	00	72	12	00	125	05	00	178	13	00
20	05	00	73	13	00	126	06	00	179	14	00
21	06	00	74	14	00	127	07	00	180	15	00
22	07	00	75	15	00	128	08	00	181	01	00
23	08	00	76	01	00	129	09	00	182	02	00
24	09	00	77	02	00	130	10	00	183	03	00
25	10	00	78	03	00	131	11	00	184	04	00
26	11	00	79	04	00	132	12	00	185	05	00
27	12	00	80	05	00	133	13	00	186	06	00
28	13	00	81	06	00	134	14	00	187	07	00
29	14	00	82	07	00	135	15	00	188	08	00
30	15	00	83	08	00	136	01	00	189	09	00
31	01	00	84	09	00	137	02	00	190	10	00
32	02	00	85	10	00	138	03	00	191	11	00
33	03	00	86	11	00	139	04	00	192	12	00
34	04	00	87	12	00	140	05	00	193	13	00
35	05	00	88	13	00	141	06	00	194	14	00
36	06	00	89	14	00	142	07	00	195	15	00
37	07	00	90	15	00	143	08	00	196	01	00
38	08	00	91	01	00	144	09	00	197	02	00
39	09	00	92	02	00	145	10	00	198	03	00
40	10	00	93	03	00	146	11	00	199	04	00
41	11	00	94	04	00	147	12	00	200	05	00
42	12	00	95	05	00	148	13	00	201	06	00
43	13	00	96	06	00	149	14	00	202	07	00
44	14	00	97	07	00	150	15	00	203	08	00
45	15	00	98	08	00	151	01	00	204	09	00
46	01	00	99	09	00	152	02	00	205	10	00
47	02	00	100	10	00	153	03	00	206	11	00
48	03	00	101	11	00	154	04	00	207	12	00
49	04	00	102	12	00	155	05	00	208	13	00
50	05	00	103	13	00	156	06	00	209	14	00
51	06	00	104	14	00	157	07	00	210	15	00
52	07	00	105	15	00	158	08	00	211	01	00
53	08	00	106	01	00	159	09	00	212	02	00

Communication Defaults for Zones (continued)

ZONE #	1st	2nd	ZONE #	1st	2nd	ZONE #	1st	2nd	ZONE #	1st	2nd
213	03	00	227	02	00	240	15	00	970	00	00
214	04	00	228	03	00	241	01	00	988	00	00
215	05	00	229	04	00	242	02	00	990	00	00
216	06	00	230	05	00	243	03	00	992 (DURESS)	11	00
217	07	00	231	06	00	244	04	00	995	00	00
218	08	00	232	07	00	245	05	00	996	00	00
219	09	00	233	08	00	246	06	00	997	06	00
220	10	00	234	09	00	247	07	00	999	60	00
221	11	00	235	10	00	248	08	00	ALARM RST.	01	00
222	12	00	236	11	00	249	09	00	TROUBLE	01	00
223	13	00	237	12	00	250	10	00	TRBLE. RST	01	00
224	14	00	238	13	00	601-632	00	00	BYPASS	00	00
225	15	00	239	14	00	800-830	00	00	BYP. RST.	00	00
226	01	00									

Zone Response Type Definitions

Each zone must be assigned a zone type, which defines the way in which the system responds to faults in that zone. There are three keypad-activated zones (panic keys; see note) for each partition, a polling loop supervision zone, and four RF supervisory zones, two for each RF receiver installed. Zone types are defined below.

Type 00: Zone Not Used

Program with this zone type if the zone is not used.

Type 01: Entry/Exit #1 Burglary

Provides entry delay whenever the zone is faulted and the system is armed in the AWAY or STAY mode. When the panel is armed in the INSTANT or MAXIMUM mode, no entry delay is provided. Exit delay begins whenever the control is armed, regardless of the arming mode selected. These delays are programmable.

Assign this zone type to zones that are used for primary entry to and exit from the facility.

Type 02: Entry/Exit #2 Burglary

Provides a secondary entry delay, if the system is armed in the AWAY or STAY modes and the zone is faulted. When the panel is armed in the INSTANT or MAXIMUM mode, no entry delay is provided. Secondary exit delay begins whenever the control is armed, regardless of the arming mode selected. These delays are programmable.

Assign this zone type to zones that are used for entry and exit of the facility and require more time than the primary entry and exit point. Delay times for this zone type must be greater than those for zone type 01 (e.g., a garage, loading dock, or basement door).

Type 03: Perimeter Burglary

Provides an instant alarm if the zone is faulted and the system is armed in the AWAY, STAY, INSTANT, or MAXIMUM mode.

Assign this zone type to all exterior doors and windows.

Type 04: Interior, Follower

Provides a delayed alarm (using the programmed entry delay time) if an entry/exit zone is faulted first. Otherwise it produces an instant alarm. It is active when the system is armed in the AWAY or MAXIMUM mode, but the MAXIMUM mode eliminates the entry delay.

If the Interior Follower zone is programmed for one of the STAY modes (default is STAY mode 1), it is automatically bypassed when the panel is armed in the STAY or INSTANT mode.

Assign this zone type to a zone covering an area such as a foyer, lobby, or hallway through which one must pass upon entry or exit (to and from the keypad).

Type 05: Trouble by Day/Alarm by Night

Provides an instant alarm if the zone is faulted and the system is armed in the AWAY, STAY, INSTANT, or MAXIMUM mode. During the disarmed state (day), the system annunciates a latched trouble sounding from the keypad (and a central station report, if desired).

Assign this zone type to a zone that contains a foil-protected door or window (such as in a store), or to a zone covering a sensitive area such as a stock room or drug supply room. It can also be used on a zone in an area where immediate notification of an entry is desired.

Type 06: 24-Hour Silent Alarm

Sends a report to the central station but provides no keypad display or sounding. Assign this zone type to a zone containing an Emergency button.

Type 07: 24-Hour Audible Alarm

Sends a report to the central station and provides an alarm sound at the keypad and an audible external alarm. Assign this zone type to a zone containing an Emergency button.

Type 08: 24-Hour Auxiliary Alarm

Sends a report to central station and provides an alarm sound at the keypad only. **(No other Notification Appliance Circuit is activated.)** Assign this zone type to a zone an Emergency button or one containing monitoring devices such as water sensors or temperature sensors.

Type 09: Supervised Fire (Without Verification)

Provides a fire alarm on a short circuit and a trouble condition on open circuit. A fire alarm produces a pulsing of the Notification Appliance Circuit. A zone of this type is always active and cannot be bypassed.

Type 10: Interior with Delay

Provides entry and exit delays (using the programmed entry and exit delay times) when armed in the AWAY mode. Provides only exit delay when armed in the MAXIMUM mode (no entry delay).

If the Interior with Delay zone is programmed for one of the STAY modes (default is STAY mode 1), it is automatically bypassed when the panel is armed in the STAY or INSTANT mode. Delay begins whenever sensors in this zone are violated, regardless of whether or not an entry/exit delay zone was tripped first.

Assign this zone type to a zone covering an area such as a foyer, lobby, or hallway through which one must pass upon entry or exit (to and from the keypad).

Type 14: PLM Supervision

Provides supervision of remote Panel Link Modules. If the communication between the local PLM and a remote PLM fails, a trouble message is produced for the PLM zone.

Type 16: Fire With Verification

Provides a fire alarm on short circuit and a trouble condition on open circuit. An initial short causes 7-second smoke detector power reset. Any subsequent short within 90 seconds causes a fire alarm. A fire alarm produces a pulsing of the Notification Appliance Circuit. A zone of this type is always active and cannot be bypassed.

Type 17: Fire Waterflow

Provides a trouble condition on open circuit and an alarm on a short circuit that remains longer than the programmed time delay (fields 3*16 and 3*18). The alarm can be silenced by either an entry of **User Code + OFF** or when the zone restores (field 3*14). This type is always active and can only be bypassed by the Installer code or the Master code, (field 3*85).

Type 18: Fire Supervisory

Provides a supervisory response on a short circuit. Open circuit can be programmed for either a trouble or supervisory response (field 3*13). This type is always active and can only be bypassed by the Installer code or the Master code, (field 3*85).

Type 19: 24-Hour Trouble

Provides a trouble response on a short or open circuit. No alarm sounders are activated.

Type 20: Arm-STAY (5800 Series devices only)

Causes the system to arm in the STAY mode when the zone is activated.

Type 21: Arm-AWAY (5800 Series devices only)

Causes the system to arm in the AWAY mode when the zone is activated.

Type 22: Disarm (5800 Series devices only)

Causes the system to disarm when the zone is activated.

Type 23: No Alarm Response

Used on a zone when an output relay action is desired, but with no accompanying alarm (e.g., for lobby door access).

Type 27: Access Point

Assign this zone type to an input device (hardwired zone, wireless zone, keypad, access control relay, etc.) that controls an access entry point (e.g., a door). The access point entry relay can be assigned to an access control relay (controlled by the FA1700C), ECP relay (4204), or to the access control system independent of the FA1700C.

Type 28: Main Logic Board (MLB) Supervision

Used to supervise the MLB. If communication between the MLB and the VISTA Gateway Module (VGM) fails, a trouble condition is annunciated for the zone. Also, if the communication fails, all access control system (ACS) input zones also display a “CHECK.”

Type 29: Momentary Exit

Used to cause an access point programmed for entry to revert to an exit point for 15 seconds. After the 15 seconds, it automatically reverts back to an entry point. Use this zone type only with VistaKey modules.

NOTE FOR PANIC KEYS: Keypad panic zones share the same zone response type for all 8 partitions, but panics may be individually enabled for each partition.

IMPORTANT! FAULT ANNUNCIATION

Polling loop and RF troubles (zones 988, 990, and 997) report as trouble conditions only, and as such, should be assigned zone type 19 if annunciation is desired. See *Polling Loop Supervision and RF System Operation and Supervision* in SECTION 3: *Installing the Control* for more information.

Zone Input Type Definitions

Each zone must be assigned an input type, which defines the where the system will “look” for status of the zone (RF receiver, polling loop, etc.). Zone input types are defined below.

Type 01 Hardwired (HW)

Reserved for the built-in hardwired zones 1-9.

Type 02 RF Motion (RM)

Select for 5800 Series transmitters. Sends periodic check-in signals, fault and low-battery signals. The control panel automatically restores the zone to “ready” after a few seconds. This type is designed for facilities with multiple motion detectors that may fault and restore simultaneously. The transmitter must remain within the receiver’s range.

NOTE: If using RF Motion with a door/window type transmitter, only loop 1 may be used.

Type 03 Supervised RF (RF)

Select for 5800 Series transmitters that will be supervised for check-in signals. The transmitter must remain within the receiver’s range.

Type 04 Unsupervised RF (UR)

Select for 5800 Series transmitters that will not be supervised for check-in signals. The transmitter may therefore be carried off-premises.

Type 05 Unsupervised Button RF (BR)

Select for 5800 Series transmitters specifically designed for this input type. These transmitters send only fault signals. They do not send low-battery signals until they are activated. The transmitter may be carried off-premises.

Type 06 Serial Number Polling Loop (SL)

Use for V-Plex devices with a built-in serial number. For VistaKey, select this type for Door Status Monitor Backup DSMB. If local power to the VistaKey is lost, a V-Plex SIM, located on the VistaKey board, is powered directly from the polling loop and reports the state of the DSM via the standard V-Plex polling system.

NOTE: To obtain the DSMB function, the Input Type must be defined as 06 and the next prompt in Zone Programming (Access Point) must contain the Access Point number (01-15) (address of the VistaKey module).

Type 07 DIP Switch Loop (DP)

Select for polling loop devices that use DIP switches for programming the zone number of the device.

Type 08 Dip Switch Polling Loop Right Loop (PS)

Select for the second loop of two-zone polling loop devices (e.g., 4190WH; 4278).

Type 09 Console Input (CS)

Select when this zone is to be controlled by a keypad input (user code + [#] + [7] + [3]) for access control.

Type 10 PassPoint Access Control (ACS)

Select when this zone is mapped to a zone on the PassPoint Access Control System.

Type 11 VistaKey Door Status Monitor (DSM)

Select this input type when using a VistaKey module connected to a door. This must be programmed for each VistaKey module to provide the DSM zone mapping a panel zone. If this is not programmed the panel will not “see” the VistaKey module.

It is also used to determine the door is opened after a card swipe or if the door is being held open. The device is normally a magnetic switch mounted on the door. The status of the switch is different when the door is in an open position.

Type 12 VistaKey Request to Exit (RTE)

Use this input type to map an uncommitted RTE zone to an alarm panel zone. This input type is not normally used if the zone is used for a request-to-exit function.

Type 13 VistaKey General Purpose (GP)

This input type operates in the same manner as other alarm panel zones and is provided so that a zone in the proximity of the VistaKey can be wired without having to run additional wiring from the control panel.

Programming for Panel Linking

Step	Action
1	Program the Panel Link Module (PLM) into the system in <i>Device Programming</i> in the #93 <i>Menu Mode</i> with Device Type 10.
2	If you want to supervise the PLM , program zone 8xx with response type 05, where “xx” = the module’s address. If you want the zone to report to the central station, make sure the report code for the zone is set with a non-zero value.

Step	Action
3	To supervise the PLMs connected to other controls , program those modules in Zone Programming with response type 14. Also, program the panel ID number. The ID number must match the ID number programmed in <i>Device Programming</i> of the control panel the PLM is connected. To report to the central station, program the report code for the zone is set with a non-zero value. Be sure to program the input type with 00.

See *Device Programming and Zone Programming in #93 Menu Mode in the Programming Guide* for a detailed explanation of the programming procedures.

Programming for the Alpha Pager Module

- In field 2*30, enter 1 to enable the Alpha Pager Module.
- Program fields 2*31 – 2*88 for the paging service parameters (see the *Programming Guide*). **The events (e.g., field 2*39) must be programmed for the pager to work.**
- In field *14, enter 1 to enable the RS232 input (J2 Pin 5).
- In field 3*19, enter 1 to enable the RS232 input (J2 Pin 5).

- If you have a printer connected to the module, program field 1*69 with a 0 for a parallel printer or a 1 for a serial printer.
- Additionally, field 05 may be programmed when using the Alpha Pager Module.



Fields for programming the delay times (e.g. 2*36 and 2*37 for pager 1) are relevant only when using numeric format for the pager.

Programming for Access Control

VistaKey

See the *VistaKey-SK Installation and Setup Guide* for the detailed programming instructions.

VistaKey Dialer Enables

When the VistaKey is installed with an alarm system, the system defaults are set so that the system does not send reports to the central station. The programming is accomplished in field 1*35 for the following events:

- ACS Troubles - To enable or disable ACS trouble reporting.
- ACS Bypasses - To enable or disable ACS bypass reporting.
- ACS System - To enable or disable ACS system reporting, (i.e., ACS module reset).
- ACS Alarms - To enable or disable ACS alarm reporting.
- Dialer (Trace) - To enable or disable access grant/denial events sent to the central station.

The PassPoint ACS can dedicate some of its inputs for use as regular control panel hardwired zones (the zone response type is ACS). The PassPoint ACS can also utilize the control panel dialer for reports to the central station.

Using ACS Zone Inputs

If the PassPoint ACS has uncommitted zones, these may be used by the FA1700C as hardwired zones. To program for ACS zone inputs, perform the following steps:

Step	Action
1	Enter Zone Programming in the #93 Menu Mode.
2	Program this zone as any other zone. Indicate the input type as ACS (10).
3	Enter the PassPoint ACS's zone ID (00-31)

See *Zone Programming in the Programming Guide* for a detailed explanation.

PassPoint Dialer Events

All PassPoint ACS events can be sent to the FA1700C dialer via the VGM. These events will also be logged into the control's event log. This is enabled in the PassPoint ACS. See the *PassPoint ACS documentation* for a detailed explanation.

Programming the VISTA Gateway Module

See the *PassPoint ACS instructions to program the VISTA Gateway Module*.

Access Control of an Entry/Exit Point Using VistaKey or PassPoint

The control can send entry and exit requests to the VistaKey or PassPoint ACS utilizing keypads and button-type (BR) RF transmitters. A zone is programmed with a response type 27 (Access Point) and an appropriate input type (console, RF).

Using the Alpha Keypad

Step	Action
1	Enter Zone Programming in the #93 Menu Mode.
2	Program the zone with a response type 27 (Access Point).
3	Enter the access point number (00-31) of the door.
4	Program whether this is an entry or exit point.
5	Enter the partition number.
6	Enter the input type as CS (09).
7	Enter the keypad ECP address.

See *Zone Programming in the Programming Guide* for a detailed explanation.

Using an RF Transmitter Zone

A button type RF transmitter (5804) can be used to provide access or egress for up to 4 doors. One button will control one door. Also, a button can be used to provide access or egress due to a panic or duress condition.

An RF transmitter (5816) can be used with a remote switch to provide exit in case of a fire alarm using a PassPoint event action.

To program the RF transmitter for access control, perform the following steps:

Step	Action
1	Enter Zone Programming in the #93 Menu Mode.
2	Program the zone with a response type 27 (Access Point).
3	Enter the access point number (00-31) of the door.
4	Indicate whether RF device is for entry or exit.
5	Enter the partition number
6	Enter the input type: button RF (05).
7	Enter the loop number.
8	Enroll the serial number

See *Zone Programming in the Programming Guide* for a detailed explanation.



- RF buttons and pendants must be assigned to a user number in order to function. See the *SECTION 9: User Access Codes* for the procedure.
- An RF transmitter will not provide access or grant if the system is in any test mode.

Using Wireless Keypads

Wireless keypads (5827 & 5827BD) can provide another way of entering or exiting the premises. They function the same as alpha keypads, except when the code + # 73 is entered. This entry will allow momentary access to ALL access points in the partition to which the keypad is assigned. To program the wireless keypad, enter the partition the keypad is assigned to in field 1*48.

Control of Lighting and Appliances

Lighting and appliances can be controlled when an access or exit event occurs. Lights or appliances can be automatically turned on or off when a valid entry or egress request is presented at an access point. To control these devices, the FA1700C relays or the ACS relays or triggers are used with keypads and/or RF transmitters whose response type is Access Point (27). To program the control of lighting and appliances, perform the following steps:

Step	Action
1	Enter Output Programming in the #93 Menu Mode.
2	Program all the information for the relay.
3	Select the output type: ECP (1) (4204/4204CF).

See *Output Programming in the Programming Guide* for a detailed explanation.

Using the FA1700C for Stand-Alone Access Control

The FA1700C can be used for access control without interfacing to PassPoint ACS or VistaKey. A user can trigger an access point (i.e., door strike) for 2 seconds by entering User Code + [0].

To program the FA1700C for Stand-Alone access control, perform the following steps:

Step	Action
1	Enter Output Programming in the #93 Menu Mode.
2	Program the output type as 1, or 2.
3	For type 1, program the ECP address and relay number.
4	For type 2, program the house and unit codes.
5	Program the relay number in field 1*76 (partition-specific).

See *Output Programming in the Programming Guide* for a detailed explanation.

Programming for ECP Long Range Radio

- Program the LRR in *Device Programming* in the #93 Menu Mode Programming.
- Program field *56: Selects the time the panel should wait before it attempts to send a message to the second destination..
- Program field *57: Selects the initial reporting destination for messages.
- Program field *58: Selects events for the primary sub's ID
- Program field *59: Selects events for the secondary sub's ID.

Programming for the Event Log

- Program field 1*70 Event Log Types (1=enable; 0=disable for each type)
- Program field 1*71 12/24-Hour Time Stamp Format (0=12 hr; 1=24 hr)
- Program field 1*72 Event Log Printer On-line (0=disable; 1=enable)
- Program field 1*73 Printer Baud Rate (1=300; 0=1200)
- Program **Event Log Report Codes** System Group #2 in the #93 Menu Mode.

Data Field Descriptions

About Data Field Programming

The following pages list this control's data fields in numerical order. Field numbers are listed in the left column, followed by a "Title and Data Entries" column, which lists the valid entries for each field. Experienced installers can simply follow this column when programming the data fields. The "Explanation" column provides explanatory information and special notes where applicable.

NOTE: Refer to the *Programming Guide* for the default values. They are not listed in this section.



Use the *Programming Guide* to record the data for this installation.

Programming Data Fields

Data field programming involves making the appropriate entries for each of the data fields. Start Data Field programming by entering the installer code + 8 + 0 + 0 + 0.

FIELD	TITLE and DATA ENTRIES	EXPLANATION
*00	Installer Code Enter 4 digits, 0-9	The Installer Code is a 4-digit code reserved for installation company use. This is the only code that can be used to enter the Program Mode from the keypad. This code cannot be used to disarm the system if it isn't used to arm the system. This code cannot be used to re-enter Program Mode if Program Mode is exited by the *98 command.
*04	Enable Random Timers For Partitions 1-8 0 = disable 1 = enable	If enabled, the activation time of the window is randomized up to 30 minutes and is initialized by either of two methods: User Code + [#] + [41] Initiates the random schedule for all devices in the partition. User Code + [#] + [42] Initiates the random schedule for all devices in the partition with a time window within 6 PM and 5 AM.
*05	System Events Notify 0 = disable 1 = enable	If enabled the system sends notification messages via the RS232 port on the J2 triggers to interface with Home Control type software. Field 3*19 must be set for RS232 (1). NOTE: If enabled, the system also sends fault and restore messages via the RS232 port.
*06	Quick Exit (partition-specific) 0 = disable 1 = enable	If enabled, allows users to exit the armed partition without disarming and then rearming the partition. Quick Exit is initiated by entering [#] + [9]. This restarts the exit delay. All rules of exit apply, including exit error logic.
*08	Temporal Siren Pulse 0 = disable 1 = enable	If enabled, the pulse rate for an output programmed for pulsing (field 3*15) will be three dings and a pause, repeated. If disabled, the pulse rate will be one second on, one second off.
*09	Entry Delay #1 (partition-specific) Enter 02-15 multiplied by 15 seconds. 00 = no delay.	Entry delay defines the delay time that allows users to re-enter the premises through a door that has been programmed as an entry delay door and disarm the system without sounding an alarm. The system must be disarmed within this period or an alarm will occur. NOTE: The delay may not exceed 45 seconds for UL installations. The entry delay time and Burg Alarm Comm Delay (field *88) combined cannot exceed 1 minute for SIA installations.

FIELD	TITLE and DATA ENTRIES	EXPLANATION
*10	Exit Delay #1 (partition-specific) Enter 03-15 multiplied by 15 seconds. 00 = no delay.	Exit delay defines the delay period that allows users to leave the premises through a door that has been programmed as an entry/exit delay door after arming the system without setting off the alarm. NOTE: The delay must be set for a minimum 45 seconds for SIA installations.
*11	Entry Delay #2 (partition-specific) Enter 02-15 multiplied by 15 seconds. 00 = no delay.	Entry Delay #2 is used for a secondary door requiring a longer delay than those assigned to Entry Delay #1. NOTE: The delay may not exceed 45 seconds for UL installations. The entry delay time and Burg Alarm Comm Delay (field *88) combined cannot exceed 1 minute for SIA installations.
*12	Exit Delay #2 (partition-specific) Enter 03-15 multiplied by 15 seconds. 00 = no delay.	Exit Delay #2 is used for a secondary door requiring a longer delay than those assigned to Exit Delay #1. NOTE: The delay may not exceed 60 seconds for UL installations. The delay must be set for a minimum 45 seconds for SIA installations.
*13	Bell 1 Timeout Enter 01-15 multiplied by 2 minutes. 00 = no timeout.	Defines the length of time the Bell 1 Output and the keypad's sounder will sound for all audible alarms. Must be minimum 16 minutes for UL Commercial Burglary installations. Must be minimum 6 minutes for UL Commercial Fire and SIA installations.
*14	Trigger or RS232 Input 0 = trigger 1 = RS232 input	Select if J2 Pin 5 should be set Fire Alarm trigger output or as an RS232 input. If set for RS232, this enables the system to receive serial data (75 baud).
<p>UL Using the RS232 input for automation is not permitted in UL installations.</p>		
*15	Keyswitch Assignment Enter 1-8 partition keyswitch is being used. Enter 9 if the keyswitch is being used to silence fire Notification Appliance Circuits in the event of a fire alarm. Enter 0 if the keyswitch is not used.	The keyswitch requires the use of zone 7 wired loop (zone 7 is no longer available as protection zone). The fire and panic alarm voltage triggers (J2) automatically become ARMING and READY status outputs for the Keyswitch LEDs. Openings/closing report as user "0" if enabled in field *40.
*16	Bell 1 Confirmation of Arming Ding (partition-specific) 0 = disable 1 = enable	If enabled, produces ½-second external alarm sounding ("ding") at the end of exit delay (or after kissoff from the central station, if sending closing reports). Must be 1 for UL commercial burglary installations.
*17	AC Loss Keypad Sounding 0 = disable 1 = enable	If enabled, sounding at the keypad (rapid beeping) occurs when AC power is lost (sounding occurs about 2 minutes after actual AC loss).
*19	Randomize AC Loss Report 0 = disable 1 = randomize for 10-40 min. after AC Loss 2 = randomize for 6-12 hours after AC Loss	If disabled, AC loss reporting about 2 minutes after actual AC loss. Selecting this option helps prevent an overload of AC loss messages at the central station during a community blackout.
*20	VIP Module Phone Code 1-9 = first digit of access code * or # = second digit of access code (enter # +11 for "*", or # +12 for "#") To disable enter 00 for the 1 st digit	If a 4285/4286 Voice Module is being used, enter the 2-digit phone code used to access the system. Must be disabled for UL installations.
*22	Keypad Panic Enables (partition-specific) 0 = disable 1 = enable	If enabled, the keypad panics (zones 995, 996, and 999) may be used in this partition. There are 3 entries in this field, one for each panic.

FIELD	TITLE and DATA ENTRIES	EXPLANATION
*23	Multiple Alarms (partition-specific) 0 = disable 1 = enable	If enabled, allows more than one alarm sounding for a given zone during an armed period. NOTE: that multiple alarm soundings will not occur more frequently than allowed by the programmed alarm sounder duration. This has no impact on the number of communication messages transmitted. Must be 1 for UL installations.
*24	Ignore Expansion Zone Tamper 0 = disable (tamper detection) 1 = enable (no tamper detection)	If disabled, the system monitors the tampers on expansion zones. NOTE: Only applicable to certain polling loop sensors with tamper switches or 5800 Series transmitters. Must be 0 for UL installations.
*25	Burglary Trigger for Response Type 8 0 = disable 1 = enable	If enabled, allows triggering of the voltage output 3 on Pin 3 of the J2 header to include zone response type 8 (24-hr. auxiliary).
*26	Intelligent Test Report 0 = disable 1 = enable	If enabled, no test report is sent if any other type of report was sent since the last test report. If disabled, test reports are sent at the set intervals, regardless of whether or not any other report has been sent. Must be 0 for UL applications.
*27	Test Report Interval Enter 0001-9999 for the test report interval in hours. Enter 0000 for test reporting.	If a test report is desired, enter a test code in <i>Report Code Programming</i> in #93 Menu Mode. Set first test report time in field *83. Maximum Test report interval is 0024 for UL commercial installations.
*28	Power-Up in Previous State 0 = disable 1 = enable	If enabled, the system, upon power-up, reverts to its status prior to a complete power loss. If disabled, the system always powers up in a disarmed state. NOTE: Neither authority level 0 nor 5 can be used to disarm the system if the control powers up armed. Must be 1 for UL applications.
*29	Quick Arm (partition-specific) 0 = disable 1 = enable	If enabled, allows arming of the burglary system in AWAY, STAY, INSTANT, or MAXIMUM mode by using the [#] key instead of the user code. NOTES: When armed, the system reports closing as User 0 if Open/Close reporting for User #2 (typically a Master level user) was enabled for a given partition. If Quick Arm is used, the Installer Code and Authority Level 5 codes cannot disarm the system.
*30	Main Dialer TouchTone or Rotary Dial 0 = rotary 1 = touchtone	Select the dialing method for the main dialer.
 If you select TouchTone, make sure the subscriber has requested and is paying for TouchTone service. Note that whether or not TouchTone dialing for call placement is permitted, communication by the use of DTMF signaling (ADEMCO High Speed) will still take place. See field 1*33 for TouchTone w/Rotary backup		
*31	PABX Access Code Enter 00-09; B-F (11-15)	This field is used to enter up to four 2-digit numbers representing the prefix needed to obtain an outside telco line. If not required, enter nothing and proceed to next field.
*32	Primary Subscriber's Account Number (partition-specific) Enter 00-09; B-F (11-15)	Enter a 3- or 4-digit (depending on report format) primary subscriber account number. Each number requires a 2-digit entry so as to allow entry of hexadecimal digits (B-F). If a 3-digit account number is to be used, enter data only in the first 3 locations, and enter * in the fourth location.
*33	Primary Phone Number Enter 0-9; #11 for *, #12 for #, #13 for a 2-second pause.	Enter the primary central station phone number, up to 17 digits. This is the phone number the control will use to transmit Alarm and status messages to the central station. Do not fill unused spaces. NOTE: Backup reporting is automatic only if a secondary phone number is entered.

FIELD	TITLE and DATA ENTRIES	EXPLANATION
*34	Secondary Phone Number Enter 0-9 ; #11 for *, #12 for #, #13 for a 2-second pause.	Enter the secondary phone number, up to 17 digits. The secondary phone number is used if communication on the primary number is unsuccessful, or if split/dual reporting is desired. Do not fill unused spaces. NOTE: If this field is programmed, a secondary subscriber account number (field *90) <i>must</i> also be programmed.
*35	Download Phone Number Enter 0-9 ; #11 for *, #12 for #, #13 for a 2-second pause.	Enter the downloading phone number, up to 17 digits. Do not fill unused spaces. NOTE: This field is applicable only if downloading is utilized.
*36	Download ID Number Make entries as 2-digit numbers as follows: 00=0 01=1 02=2 03=3 04=4 05=5 06=6 07=7 08=8 09=9 10=A 11=B 12=C 13=D 14=E 15=F	Enter eight digits. NOTE: This field is applicable only if downloading is utilized.
*37	Download Command Enables 0 = disable 1 = enable	Enabling a function means that you are able to perform that function via the Compass Downloading software. Functions are as follows: Dialer Shutdown; System Shutdown; Not Used; Remote Bypass; Remote Disarm; Remote Arm; Upload Program; Download Program. For UL commercial burglary and fire installations, all entries must be 0 .
*38	Prevent Zone XXX Bypass (partition-specific) Enter a zone number (001-250). Enter 000 if all zones can be bypassed.	Enter three digits for zone that cannot be bypassed by the user. NOTES: The actions manual bypass, group bypass, auto-stay, and STAY/INSTANT arming modes cannot bypass any zone programmed in this field. The system will not arm if the zone is programmed with the vent zone or force arm fault attributes.
*39	Enable Open/Close Report for Installer Code (partition-specific) 0 = disable 1 = enable	If enabled, whenever the Installer Code is used to arm or disarm the partition, an open/close report is sent to the central station.
*40	Enable Open/Close report for Keyswitch 0 = disable 1 = enable	If enabled, whenever the keyswitch is used to arm or disarm the partition, an open/close report is sent to the central station.
*41	Normally Closed or EOLR (Zones 3-8) 0 = disable 1 = enable	If disabled, end-of-line resistors must be used on zones 3-8. If enabled end-of-line resistors cannot be used and only normally closed devices must be used. Must be 0 for UL commercial fire and burglary installations.
*42	Dial Tone Pause Enter the wait time for dial tone detection: 0 = 5 seconds; 1 = 11 seconds; 2 = 30 seconds.	Enter the time the system waits for dial tone before dialing. Applies if true dial tone is not selected in field *43. Must be 0 for UL installations.
*43	Dial Tone Detection 0 = disable 1 = enable	If enabled, the system waits for true dial tone. If no dial tone is detected, control dials at end of pause programmed in field *42. If disabled, the system pauses for seconds entered in field *42, then dials. NOTE: Disabling may be necessary in high-noise environment telco networks where noise can be confused with dial tone, resulting in premature dialing.
*44	Ring Detection Count Enter 00 to disable ring detection. Enter 01-14 for ring counts of 1-14. Enter 15 to select Answering Machine Defeat Mode	Only applicable if using a 4285/4286 VIP Module and/or if station-initiated downloading will be used. NOTES: Do not enter 00 if a 4285/4286 is installed. In the Answering Machine Mode, the caller should let the phone ring once, then hang up, and call again within 30 seconds. The system, upon hearing one ring followed by nothing, does not answer the first call, but readies itself to pick up on the first ring of the next incoming call that is received within 30 seconds (i.e., the downloader calling again). Must be 00 for UL commercial fire and burglary installations.

FIELD	TITLE and DATA ENTRIES	EXPLANATION
*45	Primary Format 0=Low Speed; 1=Contact ID; 2=ADEMCO High Speed; 3=ADEMCO Express	Enter the reporting format for the primary telephone number.
*46	Low Speed Format (Primary) 0 = ADEMCO Low Speed 1 = Sescoa/Radionics	Enter the low speed format for the primary telephone number.
*47	Secondary Format 0=Low Speed; 1=Contact ID; 2=ADEMCO High Speed; 3=ADEMCO Express	Enter the reporting format for the secondary telephone number.
*48	Low Speed Format (Secondary) 0 = ADEMCO Low Speed 1 = Sescoa/Radionics	Enter the low speed format for the secondary telephone number.
*49	Checksum Verification Enter 2 digits, one for the primary and one for the secondary. 0 = disable 1 = enable	If enabled, the system for either or both primary/secondary formats sends a verification digit to validate the message at the receiver without having to send two message rounds. Selection is valid for 3+1, 4+1, and 4+2 reports.
*50	Sescoa/Radionics Select 0 = disable 1 = enable	If disabled, selects Radionics, which uses hexadecimal 0-9, B-F reporting. If enabled, selects Sescoa, which uses only numeric reporting (0-9). NOTE: The selection applies to both primary and secondary phone numbers.
*51	Dual Reporting 0 = disable 1 = enable	If enabled, all reports are to be sent to both primary and secondary phone numbers. NOTE: If used with Split Reporting option 1 (1*34), alarms go to both primary and secondary numbers, while all other reports go to secondary only. If used with Split Reporting option 2 , alarms go to both, open/close and test messages go to secondary only, while all other reports go to primary. If used with Split Reporting option 3 , fire alarms and supervisory reports go to primary, all other reports go to secondary.
*52	Standard/Expanded Reporting Primary 0 = disable 1 = enable	This field has six entries as follows: Alarm, Restore, Bypass, Trouble, Open/Close, Low Battery. If enabled, expanded reports are sent to the primary phone number if low speed format is selected in field *45. NOTE: Expanded overrides 4+2 format.
*53	Standard/Expanded Reporting Secondary 0 = disable 1 = enable	This field has six entries as follows: Alarm, Restore, Bypass, Trouble, Open/Close, Low Battery. If enabled, expanded reports are sent to the secondary phone number if low speed format is selected in field *47. NOTE: Expanded overrides 4+2 format.
*54	Unattended Mode 0 = disable 1 = enable	If enabled, the system automatically calls the downloader at programmed intervals. NOTE: The following fields must be programmed first: primary subscriber account number – field *32; primary phone number – field *33; downloader phone number – field *35. Or you can go into the Unattended Program Mode, from normal operating mode, by entering Installer Code + [#] + [8] + [9].
*56	Dynamic Signaling Delay Enter 00-15 times 15 seconds.	Select the time the panel should wait for acknowledgment from the first reporting destination before it attempts to send a message to the second destination (first and second destinations are determined in field *57). NOTE: If the acknowledgment is received before the delay time expires, no message is sent to the second destination.
*57	Dynamic Signaling Priority 0 = Primary Dialer 1 = Long Range Radio	Select the initial reporting path for central station messages.

FIELD	TITLE and DATA ENTRIES	EXPLANATION
*58	Long Range Radio Central Station #1 Category Enable 0 = disable 1 = enable	This field has six entries as follows: Alarm, Trouble, Bypass, Open/Close, System, Test. If enabled, the reports are sent to the primary subscriber ID of the Long Range Radio.
*59	Long Range Radio Central Station #2 Category Enable 0 = disable 1 = enable	This field has six entries as follows: Alarm, Trouble, Bypass, Open/Close, System, Test. If enabled, the reports are sent to the secondary subscriber ID of the Long Range Radio.
*77	Auto Trouble Restore 0 = disable 1 = enable	If enabled, each trouble and supervisory condition automatically clears the keypad display and stops the keypad beeping when the zone returns to a "ready/normal" state. This applies to ALL trouble and supervisory types. The system also sends the Trouble/Supervisory Restore report to the central station, if programmed. If a partition has more than one trouble/supervisory condition present at the same time, the system automatically clears the keypad display of each zone as it restores, but the keypad continues to beep until all the zones restore.
*79	Zone Type Restores for Zone Types 1-8 0 = disable 1 = enable	This field has eight entries, one for each zone type. Select the zone types that will send Restore reports.
*80	Zone Type Restores for Zone Types 9 & 10 0 = disable 1 = enable	This field has two entries, one for each zone type. Select the zone types that will send Restore reports.
*83	First Test Report Time Enter 00-07 the for day (01 = Monday) Enter 00-23 for the hour Enter 00-59 for the minutes	Enter the day and time that the first Test report shall be transmitted. Enter 00 in all locations if the Test report is to be sent immediately upon exiting. Enter 00 in the day location if the report is to be sent at the next occurrence of the time that is set.
*84	Swinger Suppression (partition-specific) Enter 01-15. Enter 00 for unlimited reports	This option limits the number of messages (alarms or troubles) sent for a specific zone in an armed period. The system automatically resets the shutdown for a zone after 48 hours if there are no trips on any zone. Must be 00 for UL commercial fire and burglary installations.
*85	Enable Dialer Reports for Panics & Duress (partition-specific) 0 = disable 1 = enable	This field has four entries as follows: Zone 995, 996, 999, Duress Enable for each partition that the panics and duress reporting is desired. NOTE: Non-zero report code must be assigned to zone 992 (duress) to enable Duress reporting.
*87	Entry Warning (partition-specific) 0 = 3 short beeps 1 = slow continuous beeps	Select the type of warning for the entry delay period.
*88	Burglary Alarm Communicator Delay (partition-specific) 0 = no delay 1 = 30-second delay	Select the delay, if any, for burglary alarm communications. Must be 0 for UL installations. Must be 1 for SIA installations.
*89	Restore Report Timing 0 = instant 1 = after bell timeout 2 = when system is disarmed	Select the time when restore reports are sent after an alarm. Must be 2 for UL commercial fire and burglary installations.

FIELD	TITLE and DATA ENTRIES	EXPLANATION
*90	Secondary Subscriber Account Number (partition-specific) Enter 00-09; B-F (11-15)	Enter a 3- or 4-digit (depending on report format) primary subscriber account number. Each number requires a 2-digit entry so as to allow entry of hexadecimal digits (B-F). If a 3-digit account number is to be used, enter data only in the first 3 locations, and enter * in the fourth location. NOTE: This field <i>must</i> be programmed if a secondary phone number is used (field *34). This account number can be the same as the primary account number.
1*15	Cancel Verify 0 = disable 1 = enable	If enabled, the system pulses the alarm output three times and displays "Cancel Sent to Central Station" when it receives a kissoff of a Cancel report. This message can only be cleared by entering the code + off. Enter 0 to disable. NOTE: Field 1*52 determines when a Cancel report is sent to the central station.
1*17	Lobby Partition 0 = none 1-8 = partition number	Select the Common Lobby Partition.
1*18	Affects Lobby (partition-specific) 0 = disable 1 = enable	If enabled, causes lobby partition to disarm when this partition disarms. NOTE: This partition must be armed before lobby can be armed.
1*19	Arms Lobby (partition-specific) 0 = disable 1 = enable	If enabled, arming this partition causes the system to attempt to arm the lobby partition. Field, field 1*18 must also be enabled (partition-specific). NOTES: The lobby cannot be armed unless all partitions programmed for "affect" (field 1*18) is already armed. If his field is enabled, Field 1*18 for this partition must also be enabled.
1*20	Exit Error Logic Enable 0 = disable 1 = enable	If enabled, the system at the end of exit delay, if an entry door or an interior zone is left open, starts the entry delay period, and activates the Notification Appliance Circuit(s), and keypad sounders for the duration of entry delay. This gives the user time to re-enter the premises and disarm the system before exit error occurs. If the user does not re-enter the premises and disarm the system, the system bypasses the faulted entry/exit and/or interior zone(s). The rest of the system is armed. Also, the following dialer reports are sent to the central station if programmed: Exit Error by User (not sent when is using ADEMCO High Speed format); Entry/Exit or Interior Alarm with the zone number; Bypass reports.
UL Exit Error Logic is not suitable for use in a UL installation (must be 0).		
1*21	Exit Delay Reset 0 = disable 1 = enable	If enabled, when the panel is armed, the normal exit delay begins. After the user exits, closes the door and then re-enters the premises, the exit delay time is reset to the programmed value. NOTES: Exit Delay Reset is designed to allow an operator to re-enter the premises to retrieve a forgotten item without triggering an alarm. This feature may only be activated once after arming. The Exit Delay must be enabled for SIA installations.
UL Exit Delay Reset is not suitable for use in a UL installation (must be 0).		

Cross-Zoning

UL Cross Zoning is not suitable for use in a UL installation.

Cross Zoning is designed so that a combination of two zones must be faulted within a 5-minute period of each other to cause an alarm on either zone. This prevents momentary faults from one of the zones from causing an alarm condition. You can select four "sets" of cross-zones (programmed in data fields 1*22, 1*23, 1*24, and 1*25), keeping in mind the following:

- Both zones in each set must protect the same area.
- Both zones in each set must be in the same partition.
- A fire zone must only be crossed to another fire zone protecting the same physical area (**see warning below**).



DO NOT cross-zone a fire zone with a burglary zone. Cross a fire zone with another fire zone only, and BOTH must be protecting the same physical area (no walls or partitions separating them). Consult NFPA 72 standard for exact spacing requirements. We recommend that spacing between fire cross-zones be no farther than 30 ft.

Conditions That Affect Cross-Zone Operation

- In the event of a continuous fault (lasting at least 5 minutes) on one of the paired zones, a fault on the second zone causes an alarm immediately.
- If one of the zones in a pair is bypassed or has a zone response type set to 0, the cross-zoning feature does not apply.
- If an entry/exit zone is paired with an interior follower zone, be sure to enter the entry/exit zone as the first zone of the pair. This ensures that the entry delay time is started before the follower zone is processed.
- If a relay is programmed to activate on a fault of one of the zones, the relay activates without the other zone being faulted.
- If a relay is programmed to activate on an alarm or trouble, both zones must trip before the relay activates, and both zones must restore for the relay to deactivate (if relay is programmed to deactivate on a Zone List Restore).



If the one of the zones trips and the second zone does not trip within the 5-minute period, an "error" message is reported to the central station. The Contact ID event code is 378.

FIELD	TITLE and DATA ENTRIES	EXPLANATION
1*22	Cross Zoning Pair One Enter 001-250 Enter 000,000 to disable	Select the first pair of cross zones, which must both be faulted within a five-minute period to cause an alarm. Must be 000,000 for UL commercial burglary installations.
1*23	Cross Zoning Pair Two Enter 001-250 Enter 000,000 to disable	Select the second pair of cross zones, which must both be faulted within a five-minute period to cause an alarm. Must be 000,000 for UL commercial burglary installations.
1*24	Cross Zoning Pair Three Enter 001-250 Enter 000,000 to disable	Select the third pair of cross zones, which must both be faulted within a five-minute period to cause an alarm. Must be 000,000 for UL commercial burglary installations.
1*25	Cross Zoning Pair Four Enter 001-250 Enter 000,000 to disable	Select the fourth pair of cross zones, which must both be faulted within a five-minute period to cause an alarm. Must be 000,000 for UL commercial burglary installations.
1*26	Panic Button or Speedkey For A, B, C keys: 00 = panic function 01-35 = macro number For D key: 00 = to select a macro to execute when key is pressed 01-35 = macro number	Select for the A, B, and C keys whether the system performs a panic or a speedkey function when the key is pressed. Select for the D key whether the system performs a specific macro or if the user will select a macro when the key is pressed. Instead of the 32 programmable speedkey functions the keys can be programmed for 3 other functions as follows: 33 = fire sounder silence. The key, when pressed, silences fire alarms. 34 = display next fire alarm. The key, when pressed, causes the keypad to display the next fire alarm in the system. 35 = display previous fire alarm. The key, when pressed, causes the keypad to display the previous fire alarm in the system. NOTES: For selection 33 enable field 3*15 for pulsing. For selections 34 and 35 enable Fire Display Lock (field 3*01). If a user code with global arm/disarm is used to execute the macro, the user's global capabilities will override any arm/disarm commands in the macro sequence.

FIELD	TITLE and DATA ENTRIES	EXPLANATION
1*28	RF Transmitter Low Battery Sound 0 = disarmed state only 1 = both armed and disarmed states	Select when the RF transmitter low-battery condition should display and audible beep annunciate on the keypad. Must be 1 for UL installations.
1*29	RF Transmitter Low Battery Reporting 0 = disable 1 = enable	If enabled, the system sends a Trouble message for RF transmitter low-battery condition to the central station. NOTE: The Trouble message will be sent for a transmitter supervision failure, independent of this selection. Must be 1 for UL installations.
1*30	RF Receiver Supervision Check-in Interval Enter 02-15 times 2 hours (4-30 hours). 00 = disable receiver supervision.	Select the check-in monitoring interval for the RF receiver(s). Failure of a receiver to receive any RF signal within the time entered results in the activation of the response type programmed for zone 990 for the first receiver and zone 988 for the second receiver and their related communication reports. Maximum is 2 (4 hr) for UL installations.
1*31	RF Transmitter Check-in Interval Enter 02-15 times 2 hours (4-30 hours). 00 = disable transmitter supervision.	Select the check-in monitoring interval for the RF transmitters. Failure of an individual transmitter to send a supervision signal within the time entered will result in a trouble response and related communication report. Maximum is 2 (4 hr) for UL installations.
1*33	TouchTone with Rotary Backup 0 = disable 1 = enable	If enabled, the system reverts to rotary dialing if communicator is not successful in dialing using TouchTone DTMF on first attempt.
1*34	Communicator Split Reporting 0 = Split Reporting disabled 1 = Alarm, Alarm Restore, and Cancel reports to primary, all others to secondary 2 = Open/Close and Test reports to secondary, all other reports to primary 3 = Fire Alarms and Fire Restores to primary, all others to secondary	Select the type of split reporting for system communication. NOTE: See *51 for split/dual reporting combinations.
1*35	Access Control Dialer Enables 0 = disable 1 = enable	There are six entries for this field as follows: Trace, Trouble, Not Used, Bypass, System, Alarm. If Trace is enabled, access grant/denial events sent to the central station. For the other events, if enabled, a report is sent to the central station.
1*42	Call Waiting Defeat 0 = disable 1 = enable	If enabled, the system defeats Call Waiting on the first outgoing call attempt to both the primary and secondary numbers. NOTES: After the panel's initial call to report the alarm, the panel may attempt to make an additional call, perhaps for a cancel or a zone restoral. If Call Waiting is not defeated, an operator at the central station attempting to contact the premises (to verify whether the alarm is valid) hears the phone ringing indefinitely and must to dispatch on the call. DO NOT enable this feature unless Call Waiting is being used.
1*43	Permanent Keypad Display Backlighting (partition-specific) 0 = disable 1 = enable	If enabled, backlighting for the keypad display remains on at all times. Otherwise the backlighting comes on when a key is pressed. NOTE: When a key is pressed, display backlighting turns on for all keypads in that partition.
1*44	Wireless Keypad Tamper Detect 0 = disable 1 = enable	If enabled, when more than 40 key depressions are received without a valid sequence (arm, disarm, etc.), the control panel disables the wireless keypad. The inhibit is removed once a valid key sequence is received from a wired keypad.

FIELD	TITLE and DATA ENTRIES	EXPLANATION
1*45	Exit Delay Sounding (partition-specific) 0 = disable 1 = enable	If enabled, the system produces slow beeping from the keypads during exit delay and reverts to rapid beeping during the last 10 seconds of the exit delay. NOTES: The duration of the beeping is the programmed value of field *10 regardless of which entry/exit zone is used to exit the premises. Exit Delay Sounding must be enabled for SIA installations. See page 32 in the <i>Programming Guide</i> , "SOUND OPTION", prompt for disabling the entry/exit beeps on individual keypads.
1*47	Chime on Bell 1 (partition-specific) 0 = disable 1 = enable	If enabled, the system produces chime annunciation on the Bell 1 output.
1*48	Wireless Keypad Assignment 0 = none 1-8 = partition number	Select the partition in which RF keypad is used.
1*49	Suppress Transmitter Supervision Sound 0 = disable 1 = enable	If enabled, no trouble soundings occur on the keypad for transmitter check-in failures. Must be 0 for UL installations.
1*52	Send Cancel If Alarm + Off (partition-specific) 0 = disable 1 = enable	If enabled, Cancel reports are sent when the system is disarmed after an alarm, regardless of how much time has gone by. If disabled, Cancel reports are sent within Bell Timeout period only. NOTE: This option must be enabled so Cancel reports are always sent.
1*53	Disable Download Callback 0 = callback required 1 = no callback required	Select whether a callback from the control panel is required for downloading. Must be 0 for UL commercial fire and burglary installations.
1*55	European Date Format 0 = disable (mm/dd/yy) 1 = enable (dd/mm/yy)	Select the date format for display in the event log.
1*56	AC 60Hz or 50Hz 0 = 60Hz 1 = 50Hz	Select the frequency for the AC. Must be set to 0 for U.S. and Canadian installations.
1*57	Enable 5800 RF Button Global Arm 0 = disable 1 = enable	If enabled, the system arms/disarms in accordance with the button's user's global arming settings.
1*58	Enable 5800 RF Button Force Arm 0 = disable 1 = enable	If enabled, allows the RF button user to force a bypass of all faulted zones when arming the system. NOTE: When attempting to arm the system, the keypad beeps once after the button is pressed if any faulted zones are present. The user should then press the button again within 4 seconds to force-bypass those zones and arm the system.
1*60	Zone 5 Audio Alarm Verification 0 = disable 1 = enable	If enabled, zone 5 is used for 2-way audio (AAV). Must be 0 for UL commercial fire and burglary installations. NOTE: Zone 5 cannot be used as protection zone.
1*69	Printer Type 0 = parallel printer 1 = serial printer	Select the printer type for the event log printout. NOTE: if you are using a parallel printer connected to the VA8201 Alpha Pager Module.

FIELD	TITLE and DATA ENTRIES	EXPLANATION
1*70	Event Log Types 0 = disable 1 = enable	This field has five entries as follows: Alarm, Check, Bypass, Open/Close, System. If enabled, the system logs those events into the event log. NOTE: Events are also logged into the PassPoint system, if installed.
1*71	12/24 Hour Type Stamp Format 0 = 12-hour 1 = 24-hour	Select the type of time stamping for the event log.
1*72	Event Log Printer On-Line Mode 0 = disable 1 = enable	If enabled, the system prints the events as they occur. If disabled, the system prints the log only upon request.
1*73	Printer Baud Rate 0 = 1200 1 = 300	Select the baud rate for the serial printer. NOTE: Must be 1 if using the alphanumeric pager interface.
1*74	Relay Timeout XXX Minutes Enter 000-127 times 2 minutes (000-254).	This is used for #80 Menu Mode Time-Driven event relay command numbers "04/09" and <i>Output Programming</i> in the #93 Menu Mode Programming output command "56."
1*75	Relay Timeout YYY Seconds Enter 000-127 seconds.	This is used for #80 Menu Mode Time-Driven event relay command numbers "05/10" and <i>Output Programming</i> in the #93 Menu Mode Programming command "57."
1*76	Access Control Relay (partition-specific) 01-96 = relay number 00 = relay not used.	If enabled, the assigned relay closes for 2 seconds when the user enters his code and presses 0. Must be 00 for UL commercial fire and burglary installations. NOTE: See SECTION 3: <i>Installing the Control</i> for enhanced access control capabilities.
1*77	Log First Maintenance Signal 0 = disable 1 = enable	If enabled, the system logs the first maintenance signal from each smoke detector. If disabled, no logging occurs.
2*00	Number of Partitions Enter 1-8.	Enter the number of partitions used in the system.
2*01	Daylight Saving Time Start/End Month 0 = disable 1 = enable	Enter the months (00-12) in which daylight saving time starts and ends. Enter 00, 00 if daylight saving time does not apply to the user's region. Standard setting for U.S. is 04,10.
2*02	Daylight Saving Time Start/End Weekend 0 = disable 1 = enable	Enter the start and end weekends for daylight saving time as follows: 1=first; 2=second; 3=third; 4=fourth; 5=last; 6=next to last; 7=third from last. Standard setting for U.S. is 1,5.
UL Fields 2*05 – 2*08 must be set to 0 for UL installations.		
2*05	Auto-Arm Delay (partition-specific) 00 = no delay. 01-14 times 4 minutes (04-56) delay. 15 = no auto arming.	This is the time between the end of the arming window and the start of auto-arm warning time (field 2*06).
2*06	Auto-Arm Warning Period (partition-specific) 01-15 times 1-minute warning. 00 = no warning period.	This is the time that the user is warned by a keypad sounding and display to exit the premises prior to auto arming of the system.

FIELD	TITLE and DATA ENTRIES	EXPLANATION
2*07	Auto-Disarm Delay (partition-specific) 00 = no delay. 01-14 times 4 minutes (04-56) delay. 15 = no auto disarming.	This is the time between the end of the disarming window and the start of auto disarming of the system.
2*08	Force Arm Enable for Auto-Arm (partition-specific) 0 = disable 1 = enable	If enabled, the system automatically bypasses any faulted zones when it attempts to auto-arm. If disabled, the system will not auto-arm.
2*09	Open/Close Reports by Exception (partition-specific) 0 = disable 1 = enable	If enabled, Open/Close reports are sent only if the openings/closings occur outside the arm and disarm windows. NOTES: Open reports are also suppressed during the closing window in order to prevent false alarms if the user arms the system, then re-enters the premises, for example to retrieve a forgotten item. Openings and closings are still recorded in the event log. This field must be set to 1 if No Opening and No Closing reports are to be sent.
2*10	Allow Disarming Only During Arm/Disarm Windows (partition-specific) 0 = disable 1 = enable	If enabled, disarming of the system is allowed only during the arming/disarming windows, or if the system is in alarm (if 2*11 is set to 1). NOTE: This applies only to Operator-level users. Installer, Master, and Manager-level users can disarm the system at any time.
2*11	Allow Disarm Outside Window if Alarm Occurs 0 = disable 1 = enable	If enabled, allows the system to be disarmed outside the programmed disarm (opening) window if an alarm has occurred. Otherwise disarming is allowed only during the disarm window. NOTE: Used only if field 2*10 is enabled.
2*18	Enable GOTO for this Partition (partition-specific) 0 = disable 1 = enable	If enabled, this partition can be accessed from another partition's keypad using the GOTO command.
2*19	Use Partition Descriptor 0 = disable 1 = enable	If enabled, the normal keypad display will include a partition number and four-digit descriptor.
2*20	Enable J2 Triggers for Partition (partition-specific) 0 = disable 1 = enable	If enabled, the J2 triggers function for this partition.
2*21	Supervision Pulses for LRR 0 = disable 1 = enable	There are three entries in this field as follows: Fire, Burglary/Audible Panic, Silent Panic/Duress. If enabled, causes the control to send periodic short pulses on the J2 radio triggers to the LRR. The LRR uses these pulses to determine that its connection to the control is still intact. Must be 1 for UL commercial fire and burglary installations.
2*22	Display Fire Alarms of Other Partitions (partition-specific) 0 = disable 1 = enable	If enabled, allows fire alarms that occur on other partitions to be displayed at this partition's keypad(s).

FIELD	TITLE and DATA ENTRIES	EXPLANATION
2*23	Display Burglary & Panic Alarms for Other Partitions (partition-specific) 0 = disable 1 = enable	If enabled, allows burglary and panic alarms that occur on other partitions to be displayed at this partition's keypad(s).
2*24	Display Troubles of Other Partitions (partition-specific) 0 = disable 1 = enable	If enabled, allows troubles that occur on other partitions to be displayed at this partition's keypad(s).
2*30	Pager Installed 0 = disable 1 = enable	Enable if the Alphanumeric Pager Module (VA8201) interface is installed. NOTE: The APM is needed for alphanumeric type paging and/or printing to a parallel printer.
2*31	Delay Paging 0 = disable 1 = enable	This field has eight locations, one for each pager. If enabled, the system waits the delay time specified in field 2*32 before transmitting the message after the dialer completes sending the message.
2*32	Time to Delay Pager After Dialer 000-024 times 10 seconds (010-240).	This delay should be set to allow enough time for the central station to call back the premises in order to verify an alarm condition. Field 2*31 must be enabled.
2*33	Pager 1 Phone Number Enter 0-9; #11 for *, #12 for #, #13 for a 2-second pause.	Enter the paging service phone number for Pager 1. Enter up to 17 digits. Do not fill unused spaces.
2*34	Pager 1 ID Number Enter 0-9	Enter the Pager ID number for Pager 1. Enter up to 10 digits.
2*35	Pager 1 Format 0 = numeric 1 = ID 2 = alphanumeric	Enter the pager format for Pager 1.
2*36	Pager 1 Delay 1 000-060 seconds.	This delay occurs after the phone number is dialed and before the pager ID is sent, giving the pager system time to answer the phone call. NOTE: Program only if using numeric format.
2*37	Pager 1 Delay 2 000-060 seconds.	This delay occurs after the pager ID is sent and before the event information is sent. NOTE: Program only if using numeric format.
2*38	Pager 1 Partition Enable 0 = disable 1 = enable	This field has eight entries, one for each partition. If enabled, the system sends messages to Pager 1 for the partition(s).
2*39	Pager 1 Trigger Event Enables 0 = disable 1 = enable	This field has six entries as follows: Alarm, Trouble, Bypass, Open/Close, System, Test. If enabled, the system sends a signal to the pager.
2*40	Pager 2 Phone Number Enter 0-9; #11 for *, #12 for #, #13 for a 2-second pause.	Enter the paging service phone number for Pager 2. Enter up to 17 digits. Do not fill unused spaces.
2*41	Pager 2 ID Number Enter 0-9	Enter the Pager ID number for Pager 2. Enter up to 10 digits.

FIELD	TITLE and DATA ENTRIES	EXPLANATION
2*42	Pager 2 Format 0 = numeric 1 = ID 2 = alphanumeric	Enter the pager format for Pager 2.
2*43	Pager 2 Delay 1 000-060 seconds.	This delay occurs after the phone number is dialed and before the pager ID is sent, giving the pager system time to answer the phone call. NOTE: Program only if using numeric format.
2*44	Pager 2 Delay 2 000-060 seconds.	This delay occurs after the pager ID is sent and before the event information is sent. NOTE: Program only if using numeric format.
2*45	Pager 2 Partition Enable 0 = disable 1 = enable	This field has eight entries, one for each partition. If enabled, the system sends messages to Pager 2 for the partition(s).
2*46	Pager 2 Trigger Event Enables 0 = disable 1 = enable	This field has six entries as follows: Alarm, Trouble, Bypass, Open/Close, System, Test. If enabled, the system sends a signal to the pager.
2*47	Pager 3 Phone Number Enter 0-9; #11 for *, #12 for #, #13 for a 2-second pause.	Enter the paging service phone number for Pager 3. Enter up to 17 digits. Do not fill unused spaces.
2*48	Pager 3 ID Number Enter 0-9	Enter the Pager ID number for Pager 3. Enter up to 10 digits.
2*49	Pager 3 Format 0 = numeric 1 = ID 2 = alphanumeric	Enter the pager format for Pager 3.
2*50	Pager 3 Delay 1 000-060 seconds.	This delay occurs after the phone number is dialed and before the pager ID is sent, giving the pager system time to answer the phone call. NOTE: Program only if using numeric format.
2*51	Pager 3 Delay 2 000-060 seconds.	This delay occurs after the pager ID is sent and before the event information is sent. NOTE: Program only if using numeric format.
2*52	Pager 3 Partition Enable 0 = disable 1 = enable	This field has eight entries, one for each partition. If enabled, the system sends messages to Pager 3 for the partition(s).
2*53	Pager 3 Trigger Event Enables 0 = disable 1 = enable	This field has six entries as follows: Alarm, Trouble, Bypass, Open/Close, System, Test. If enabled, the system sends a signal to the pager.
2*54	Pager 4 Phone Number Enter 0-9; #11 for *, #12 for #, #13 for a 2-second pause.	Enter the paging service phone number for Pager 4. Enter up to 17 digits. Do not fill unused spaces.
2*55	Pager 4 ID Number Enter 0-9	Enter the Pager ID number for Pager 4. Enter up to 10 digits.
2*56	Pager 4 Format 0 = numeric 1 = ID 2 = alphanumeric	Enter the pager format for Pager 4.

FIELD	TITLE and DATA ENTRIES	EXPLANATION
2*57	Pager 4 Delay 1 000-060 seconds.	This delay occurs after the phone number is dialed and before the pager ID is sent, giving the pager system time to answer the phone call. NOTE: Program only if using numeric format.
2*58	Pager 4 Delay 2 000-060 seconds.	This delay occurs after the pager ID is sent and before the event information is sent. NOTE: Program only if using numeric format.
2*59	Pager 4 Partition Enable 0 = disable 1 = enable	This field has eight entries, one for each partition. If enabled, the system sends messages to Pager 4 for the partition(s).
2*60	Pager 4 Trigger Event Enables 0 = disable 1 = enable	This field has six entries as follows: Alarm, Trouble, Bypass, Open/Close, System, Test. If enabled, the system sends a signal to the pager.
2*61	Pager 5 Phone Number Enter 0-9; #11 for *, #12 for #, #13 for a 2-second pause.	Enter the paging service phone number for Pager 5. Enter up to 17 digits. Do not fill unused spaces.
2*62	Pager 5 ID Number Enter 0-9	Enter the Pager ID number for Pager 5. Enter up to 10 digits.
2*63	Pager 5 Format 0 = numeric 1 = ID 2 = alphanumeric	Enter the pager format for Pager 5.
2*64	Pager 5 Delay 1 000-060 seconds.	This delay occurs after the phone number is dialed and before the pager ID is sent, giving the pager system time to answer the phone call. NOTE: Program only if using numeric format.
2*65	Pager 5 Delay 2 000-060 seconds.	This delay occurs after the pager ID is sent and before the event information is sent. NOTE: Program only if using numeric format.
2*66	Pager 5 Partition Enable 0 = disable 1 = enable	This field has eight entries, one for each partition. If enabled, the system sends messages to Pager 5 for the partition(s).
2*67	Pager 5 Trigger Event Enables 0 = disable 1 = enable	This field has six entries as follows: Alarm, Trouble, Bypass, Open/Close, System, Test. If enabled, the system sends a signal to the pager.
2*68	Pager 6 Phone Number Enter 0-9; #11 for *, #12 for #, #13 for a 2-second pause.	Enter the paging service phone number for Pager 6. Enter up to 17 digits. Do not fill unused spaces.
2*69	Pager 6 ID Number Enter 0-9	Enter the Pager ID number for Pager 6. Enter up to 10 digits.
2*70	Pager 6 Format 0 = numeric 1 = ID 2 = alphanumeric	Enter the pager format for Pager 6.
2*71	Pager 6 Delay 1 000-060 seconds.	This delay occurs after the phone number is dialed and before the pager ID is sent, giving the pager system time to answer the phone call. NOTE: Program only if using numeric format.

FIELD	TITLE and DATA ENTRIES	EXPLANATION
2*72	Pager 6 Delay 2 000-060 seconds.	This delay occurs after the pager ID is sent and before the event information is sent. NOTE: Program only if using numeric format.
2*73	Pager 6 Partition Enable 0 = disable 1 = enable	This field has eight entries, one for each partition. If enabled, the system sends messages to Pager 6 for the partition(s).
2*74	Pager 6 Trigger Event Enables 0 = disable 1 = enable	This field has six entries as follows: Alarm, Trouble, Bypass, Open/Close, System, Test. If enabled, the system sends a signal to the pager.
2*75	Pager 7 Phone Number Enter 0-9; #11 for *, #12 for #, #13 for a 2-second pause.	Enter the paging service phone number for Pager 7. Enter up to 17 digits. Do not fill unused spaces.
2*76	Pager 7 ID Number Enter 0-9	Enter the Pager ID number for Pager 7. Enter up to 10 digits.
2*77	Pager 7 Format 0 = numeric 1 = ID 2 = alphanumeric	Enter the pager format for Pager 7.
2*78	Pager 7 Delay 1 000-060 seconds.	This delay occurs after the phone number is dialed and before the pager ID is sent, giving the pager system time to answer the phone call. NOTE: Program only if using numeric format.
2*79	Pager 7 Delay 2 000-060 seconds.	This delay occurs after the pager ID is sent and before the event information is sent. NOTE: Program only if using numeric format.
2*80	Pager 7 Partition Enable 0 = disable 1 = enable	This field has eight entries, one for each partition. If enabled, the system sends messages to Pager 7 for the partition(s).
2*81	Pager 7 Trigger Event Enables 0 = disable 1 = enable	This field has six entries as follows: Alarm, Trouble, Bypass, Open/Close, System, Test. If enabled, the system sends a signal to the pager.
2*82	Pager 8 Phone Number Enter 0-9; #11 for *, #12 for #, #13 for a 2-second pause.	Enter the paging service phone number for Pager 8. Enter up to 17 digits. Do not fill unused spaces.
2*83	Pager 8 ID Number Enter 0-9	Enter the Pager ID number for Pager 8. Enter up to 10 digits.
2*84	Pager 8 Format 0 = numeric 1 = ID 2 = alphanumeric	Enter the pager format for Pager 8.
2*85	Pager 8 Delay 1 000-060 seconds.	This delay occurs after the phone number is dialed and before the pager ID is sent, giving the pager system time to answer the phone call. NOTE: Program only if using numeric format.
2*86	Pager 8 Delay 2 000-060 seconds.	This delay occurs after the pager ID is sent and before the event information is sent. NOTE: Program only if using numeric format.
2*87	Pager 8 Partition Enable 0 = disable 1 = enable	This field has eight entries, one for each partition. If enabled, the system sends messages to Pager 8 for the partition(s).

FIELD	TITLE and DATA ENTRIES	EXPLANATION
2*88	Pager 8 Trigger Event Enables 0 = disable 1 = enable	This field has six entries as follows: Alarm, Trouble, Bypass, Open/Close, System, Test. If enabled, the system sends a signal to the pager.
3*00	Check or TRBL Display 0 = CHECK 1 = TRBL	Select whether the system should display CHECK or TRBL when a trouble condition occurs.
3*01	Fire Display Lock 0 = disable 1 = enable	If enabled, the system locks the display on the first fire alarm. Press * to display the next fire alarm in the system. If disabled, the system scrolls all alarms automatically.
3*12	Zone Type 18 Delay Use 0 = disable 1 = enable	If enabled, use the delay time programmed in field 3*16.
3*13	Supervisory on Open and Short 0 = disable 1 = enable	If enabled, the system produces a supervisory response on an open or short circuit. If disabled, a short circuit produces a supervisory response and an open produces a trouble response.
3*14	Waterflow Alarm Silence Option 0 = silenced by User Code + OFF 1 = silenced when zone restores	Select how the Waterflow zone type will be silenced. NOTE: This feature may be set to 1 only by permission of the local authority.
3*15	Alarm Sounds Bell 1 & 2 0 = pulsing 1 = steady	This field has two entries, one for each Notification Appliance Circuits. If set for pulsing, field *08 applies.
3*16	Zone Types 17 & 18 Delay Enter 01-15 times 2 seconds Enter 00 for no delay	Select the delay time for zone types 17 and 18. The zone must be faulted for entire delay time before an alarm or supervisory condition occurs. This may prevent alarms due to minor fluctuations in waterflow.
3*17	Zone 6 Alternate Function Enable 0 = disable 1 = enable	If enabled, zone 6 may be used as a tamper zone (bell and cabinet tampers).
3*18	Extended Delay for Zone Types 17 & 18 0 = no extended delay 1 = multiply delay by 4	This option allows the delay programmed in field 3*16 for Waterflow and Supervisory zones to be extended by 4 times.
UL For Waterflow alarms, total maximum allowable time delay (device and panel) is 90 seconds. For Fire Supervisory signals, total maximum allowable time delay (device and panel) is 200 seconds.		
3*19	Auxiliary Input Alternate Function Enable 0 = disable 1 = enable	If enabled, pins 5 and 9 on the J2 connector function as RS232 output and input, respectively. If disabled, they function as fire alarm trigger and LRR Xmit Okay. See the chart at field 3*20 for the J2 trigger configurations. NOTE: If field 3*19 is enabled, you cannot use a LRR connected to the J2 trigger.

FIELD	TITLE and DATA ENTRIES	EXPLANATION
-------	------------------------	-------------

3*20 **Trigger Outputs Function Selection** Select the function of the J2 trigger outputs. See chart below.

0 = remote keypad sounder
 1 = keyswitch LEDs
 2 = 5140LED connection

J2 Pin	Field 3*19 = 0 Field3*20 = 0	Field 3*19 = 0 Field3*20 = 1	Field 3*19 = 0 Field3*20 = 2	Field 3*19 = 1
1	Panic Alarm	Panic Alarm	5140LED Dialer 1 Fail LED	As selected in field 3*20
2	Trouble	Trouble	Trouble	As selected in field 3*20
3	Burglary Alarm	Burglary Alarm	5140LED COMM Fail LED	As selected in field 3*20
4	Fire Supervisory	Fire Supervisory	Fire Supervisory	As selected in field 3*20
5	Fire Alarm	Fire Alarm	Fire Alarm	RS232 Output
6	Remote Console Sounder	Keyswitch Ready LED	5140LED Dialer 2 Fail LED	As selected in field 3*20
7	Open/Close	Keyswitch Armed LED	5140LED AC Fail LED	As selected in field 3*20
8	Ground	Ground	Ground	Ground
9	LRR Xmit Okay	LRR Xmit Okay	LRR Xmit Okay	RS232 Input

3*21 **Maximum Number of Dialer Attempts** Select the maximum number of dialer attempts for the system.

Enter the number of dialing attempts 1-8. **NOTE:** Must be 3, 4, or 5 for NFPA 72 compliant systems if a secondary phone number is programmed.

3*30 **Dialer Selection** This field has two entries, one for each dialer (main and backup). Enter 1 if the dialer is being used.

0 = disable
 1 = enable

3*31 **Backup Dialer TouchTone or Rotary** Select the dialing method for the backup dialer.

0 = rotary
 1 = touchtone

3*50 **Zone Type Restore Enables for Types 16-18** This field has three entries, one for each zone type. Select the zone types that will send Restore reports.

0 = disable
 1 = enable Must be 1 for UL commercial fire and burglary installations.

3*55 **Reset on Second OFF for Bell 1** If enabled, the system resets bell 1 output when the second **User Code + OFF** Code is entered after a fire alarm. If disabled, the system resets bell 1 output after the first **User Code + OFF**.

0 = disable
 1 = enable

3*56 **Reset on Second OFF for Bell 2** If enabled, the system resets bell 2 output when the second **User Code + OFF** Code is entered after a fire alarm. If disabled, the system resets bell 2 output after the first **User Code + OFF**.

0 = disable
 1 = enable

3*57 **Confirmation of Arming Ding Bell 2 & Auxiliary Relay** This field has two entries, one for bell 2 and one for the auxiliary relay. If enabled, produces ½-second external alarm sounding (“ding”) at the end of exit delay (or after kissoff from the central station, if sending closing reports).

0 = disable
 1 = enable Must be 1 for UL commercial burglary installations.

3*59 **Enable Bell 2 & Auxiliary Relay Chime Annunciation** This field has two entries, one for bell 2 and one for the auxiliary relay. If enabled, the system produces chime annunciation on the output.

0 = disable
 1 = enable

FIELD	TITLE and DATA ENTRIES	EXPLANATION
3*60	Bell 2 & Auxiliary Relay Timeout Enter 01-15 multiplied by 2 minutes. 00 = no timeout.	This field has two entries, one for bell 2 and one for the auxiliary relay. Defines the length of time the output and the keypad's sounder will sound for all audible alarms. Must be a minimum of 16 minutes for UL commercial burglary installations and a minimum 6 minutes for UL commercial fire installations.
3*61	Auxiliary Relay Function Selection 0 = trouble/supervisory 1 = alarm, silenced by User Code + OFF 2 = smoke detector reset 3 = battery save 4 = alarm, silenced by User Code + # + 67	Select the condition that will trigger the auxiliary relay. NOTES: Smoke detector reset triggers the relay momentarily (approximately 6 seconds) on the second User Code + OFF entry. Battery save is used to disconnect power from non-critical loads 4 hours after AC loss.
3*82	Burglary Features on Partition 1 Enable 0 = disable 1 = enable	If enabled, arming, test and chime modes can be used on partition 1. NOTE: These features are automatically enabled on all other partitions.
3*85	System Zone Bypass Inhibit 0 = prevent bypass 1 = allow only installer to bypass 2 = allow only installer and master codes to bypass	Select which codes, if any, can bypass fire zones and systems zones. NOTES: This applies to fire zones programmed with zone types 9, 16, 17, and 18 and system zones 970-977. The bypassing can only be done from partition 1.

Scheduling Options

UL

- You must program Bypass and Auto-Arm Fail reports for UL installations.
- Auto-disarming is not permitted in UL installations.
- You must not program Random Scheduling of Time Driven Events for UL installations.

General

The scheduling features allow certain operations to be automated, such as arming, disarming, bypassing of zones, and activating relay outputs.

The system uses time windows (a programmed period of time with a start and stop time) for defining open/close schedules, holiday schedules, user-defined temporary schedules, and access schedules for users.

Scheduled events are programmed by user-friendly menu modes of programming (#80, #81, #83, and #93 modes), explained in detail in this section. These menus take you step by step through the options.

Auto Arming

The system can automatically arm (AWAY Mode) a partition at the end of a pre-determined closing (arming) time window.

Auto Arming can be delayed three ways: by use of the Auto-Arm Delay, the Auto-Arm Warning, or by manually extending the closing (arming) time window with a keypad command.

The system can also automatically bypass any open zones when auto arming.

Auto-Arm Delay

Auto-Arm Delay provides a delay (grace period) before auto arming. It starts at the end of the closing time window.

The delay is set in 4-minute increments, up to 56 minutes in partition-specific program field 2*05. At the expiration of this delay, the Auto-Arm Warning will start.

Auto-Arm Warning

The Auto-Arm Warning causes the keypad sounder to warn the user of an impending Auto-Arm.

The warning can be set from 1 to 15 minutes prior to the arming in partition-specific program field 2*06. During this period the keypad beeps every 15 seconds and displays "AUTO ARM ALERT." During the last 60 seconds, the keypads beep every 5 seconds.

The panel arms at the conclusion of the Auto-Arm Warning period.

Extend Closing Window

A user can manually delay the arm (closing) time window by 1 or 2 hours. This is done by entering a keypad command (User Code + #82), which then prompts the user to enter the desired extension time of 1 or 2.

This feature is useful if a user must stay on the premises later than usual.

The Auto-Arm delay and warning periods begin at the end of the extension.

Force Arm

The Force Arm option causes the panel to attempt to bypass any faulted zones prior to auto arming (panel performs a force-arm).

This option is set in partition-specific program field 2*08.

Auto Disarming

The system can automatically disarm a partition at the end of a pre-determined opening (disarm) time window.

The disarming time can be delayed by using the Auto-Disarm Delay feature.

Disarm Delay

Auto-Disarm Delay provides a delay before auto disarming. This delay is added to the end of the disarm time window.

The delay is set in 4-minute increments, up to 56 minutes, in partition-specific program field 2*07.

Restrict Disarming

This option allows disarming by users only during the disarm time window and during the arming time window (in case user needs to re-enter premises after manually arming the partition).

This option is set in partition-specific field 2*10. If field 2*10 is set, we highly recommend setting field 2*11, as well. This field allows the partition to be disarmed outside the arm/disarm time windows only if the partition is in alarm.

Exception Reports

This option allows the reporting of openings and closings to the central station only if the arming and disarming occurs outside of the predetermined opening and closing time windows. It is set in partition-specific field 2*09.

The system can be programmed to send Failed to Open and Failed to Close reports if the partition is not armed or disarmed by the end of the corresponding time window.

Limitation of Access of Users by Time

A user’s access to the system can be limited to a certain time period. Outside this time, that user’s code is inactive. The system provides up to 8 access schedules, each consisting of two time windows (typically one for opening, one for closing) for each day of the week and two time windows for holidays.

The access schedules are programmed in the #80 Menu Mode, and enabled when a user’s access code is added to the system.

If a user tries to operate the system outside the schedule, the alpha keypad displays “Access Denied.”

Time-Driven Events

The system can automatically activate and de-activate relays at predetermined times to turn lights or other devices on and off. The Time-Driven events can be activated at different times in relation to a time window:

- At the beginning of a time window
- At the end of a time window
- During a time window (on at beginning of window, off at end)
- At both the beginning and end of the time window (e.g., to sound a buzzer at the beginning and end of a coffee break)
- Random time at the start of the time window (occurs within 30 minutes after the start of the time window)
- Random time at the end of the time window (occurs within 30 minutes after the end of the time window)
- Random during the time window (begins within 30 minutes after the start of the time window and ends within 30 minutes after the end of the time window)

The system can perform the same actions on a daily basis, or can perform an action only once (e.g., turn on the porch light this Wednesday at 8:00 PM).

The system also provides up to 20 programmable “timers” available to the end user for the purpose of activating output devices at preset times and days.

Time Window Definitions

Scheduled events are based on time windows, (periods of time) during which an event may take place. The system supports up to 20 time windows, each defined by a “Start” time and a “Stop” time.

The windows are shared by all 8 partitions, and are used when programming the various schedules (open/close, limitation of access), as well as for Time-Driven event control.

Scheduling Example

A store that has the following hours:

Monday to Friday	9am to 6pm
Saturday	10am to 4pm
Sunday	Closed
Holidays	Closed

The owner desires the following time windows to allow time for employees to arm or disarm the system:

Monday to Friday	Open (disarm)	8am to 9am
	Close (arm)	6pm to 6:30pm
Saturday	Open (disarm)	9am to 10am
	Close (arm)	4pm to 4:30pm
Sunday & Holidays	Closed	

For this schedule, the four time windows need to be programmed:

Window	Start	Stop	Purpose
1	8am	9am	Monday-Friday open window
2	9am	10am	Saturday open window
3	4pm	4:30pm	Saturday close window
4	6pm	6:30pm	Monday-Fri. close window

Using the #80 Menu Mode, the installer can program open/close schedules by assigning a time window to a day of the week (windows are entered as 2-digit entries)

Mon	Tue	Wed	Thu	Fri	Sat	Sun	Hol
Op/Cl	Op/Cl	Op/Cl	Op/Cl	Op/Cl	Op/Cl	Op/Cl	Op/Cl
01/04	01/04	01/04	01/04	01/05	02/03	00/00	00/00

NOTE: 00 is entered for those days on which the store is closed.

Employees can arm and disarm the system, when programmed, within the open and close time windows without causing a report to be sent to the central station (reporting by exception, field 2*09). The system can be programmed to automatically arm/disarm in case an employee fails to arm/disarm manually (auto-arm/auto-disarm).

Open/Close Schedules Definitions

General

The open/close scheduling is controlled by one of three schedules. Each schedule consists of one time window for openings and one time window for closings.

There are three types of schedules available: Daily, Holiday, and Temporary.

Daily Schedule

Each partition can have one daily schedule consisting of one opening window and one closing window per day.

Holiday Schedule

A holiday schedule overrides the regular daily schedule on selected holidays throughout the year.

The opening and closing windows are programmed in the daily schedule, but the holidays themselves are defined in *Holiday Schedule Programming* in the #80 *Menu Mode*.

Temporary Schedule

The temporary schedule provides a method for the end user to override the daily and holiday schedules. It consists of one opening window and one closing window for each day of the week. The schedule takes effect for up to one week, after which it is automatically deactivated.

This schedule is programmed using the #81 Temporary Schedule Menu Mode.

Additional Schedules

Additional opening and closing schedules can be programmed using the *Time-Driven Event Programming*. For example, a schedule for normal store openings/closings can be programmed with a daily open/close schedule, and another open/close schedule for a lunch hour can be programmed using the Time-Driven event schedule programming.

Refer to “Time-Driven Events” later in this section for detailed information.

Open/Close Reports by Exception

The system can help reduce communication traffic to the central station by using the Open/Close Reports by Exception feature. The Open/Close by Exception option suppresses these reports from being sent to the central station if an arm or disarm is done *within* the expected time window. Reports are only sent if the arm or disarm occurs outside the assigned time window.

The system keeps a record of *all* openings/closings in its event log.

If a disarming occurs during a closing window (for example, a person who arms the system forgets something and has to re-enter), the Opening report (although outside of the opening window) will not be sent (as long as that disarming occurs within the closing window).

This option is programmed in partition-specific program field 2*09.

Example of Open/Close Exception Reporting & Scheduling

The following chart gives an example of how the Open/Close by Exception reporting works.

6:01PM	5:59AM	6AM	9AM	9:01AM	3:59PM	4PM	6PM	6:01PM	5:59AM
<p>Early Opening reports are sent if system is manually disarmed before opening window begins.</p> <p>Early and Late Opening and Closing reports are programmable options in Report Code Programming in the Programming Guide. They are not dependent on the programming of the Exception Reporting option.</p>	<p style="text-align: center;">Opening Window</p> <p>No reports are sent if system is disarmed during this time window.</p> <p>If an arming occurs, a Closing report is sent to the central station regardless of how the Exception Reporting option is set.</p>	<p>Auto-disarm delay begins.</p> <p>Auto-disarm occurs after delay (if auto-disarm is enabled).</p> <p>Missed Opening reports are sent if manual disarming has not occurred at expiration of opening window.</p> <p>Late Opening reports are sent if disarm occurs after the opening window expires.</p> <p>Early Closing reports are sent if manual arming occurs before the closing window begins.</p> <p>Missed Opening/Closing type reports are programmed in Report Code Programming in the Programming Guide. The Exception Reporting option must be set for these to be sent.</p>	<p style="text-align: center;">Closing Window</p> <p>No reports are sent if system is armed* during this time window.</p> <p>* or disarmed if user needs to re-enter premises.</p>	<p>Auto-arm delay begins.</p> <p>Auto-arm warning begins.</p> <p>Auto-arm occurs after warning expires (if auto-arm is enabled).</p> <p>Missed Closing reports are sent if manual arming has not occurred at expiration of closing window.</p> <p>Late Closing reports are sent if system is manually armed after the closing window expires.</p>					

Scheduling Menu Mode

The #80 Scheduling Menu Mode is used to program most of the scheduling and timed-event options. Enter **Installer Code + [#] + [8] + [0]** from the normal operating mode. **NOTE:** Only users with an Installer or Master level user code may enter the #80 mode.

The following can be programmed while in this mode:

- time windows
- open/close schedules to each partition
- holiday schedules
- Time-Driven events (for system functions and relay activation)
- limitation of access schedules

Some scheduling features are programmed in Data Field Programming Mode (**Installer Code + 8 0 0 0**). Some features are programmed in the #93 Menu Mode. The programming scheduling fields are listed below.

System-Wide Fields:	
*04	Enable Random Timers
1*74 –1*75	Relay timeout values
2*01-2*02	Daylight saving time options
2*11	Allow disarming outside window if alarm occurs
Partition-Specific fields:	
1*76	Access control relay for this partition
2*05	Auto-arm delay value
2*06	Auto-arm warning time
2*07	Auto-disarm delay value
2*08	Force-arm enable
2*09	Open/Close Reporting by Exception
2*10	Restrict disarm only during windows
#93 Menu Mode (System Group #3)	
Scheduling related report codes	

Event-driven options are programmed using *Output Programming in #93 Menu Mode*. Relay activation can also be Time-Driven and that those are programmed using the *#80 Menu Mode*. Refer to the *Time-Driven Event Programming* later in this section for the procedure.

There are 6 procedures of scheduling menus accessed via #80, as shown below. Entering **1** at a displayed main menu prompt selects that menu procedure. Prompts for programming that scheduling feature then appear. Enter **0** to skip a procedure and display the next menu option.

PROMPT	EXPLANATION
Time Window ? 1 = YES 0 = NO 0	Upon entering Schedule Menu Mode, this prompt appears. Enter 1 to program time windows. Refer to <i>Time Windows Programming</i> later in this section for detailed procedures. Enter 0 to move to the “O/C Schedules?” prompt.
O/C Schedules ? 1 = YES 0 = NO 0	Enter 1 to program opening and closing schedules. Refer to <i>Open/Close Schedules Programming</i> later in this section for detailed procedures. Enter 0 to move to the “Holidays?” prompt.
Holidays ? 1 = YES 0 = NO 0	Enter 1 to program holiday schedules. Refer to <i>Holiday Schedule Programming</i> later in this section for detailed procedures. Enter 0 to move to the “Timed Events?” prompt.
Timed Events ? 1 = YES 0 = NO 0	Enter 1 to program timed events for relay outputs, additional schedules, and other system functions. Refer to <i>Time-Driven Event Programming</i> later in this section for detailed procedures. Enter 0 to move to the “Access Sched?” prompt.

Steps to Program Scheduling Options



This section contains examples of the worksheets only. For complete worksheets, see the *Programming Guide* accompanying this Installation and Setup Guide.

In order to use #80 Scheduling Menu Mode, use the worksheets to do the following:

1. Define time windows (up to 20)
2. Define the daily open/close schedules (one schedule per day, per partition)
3. Define the holidays to be used by the system (up to 16)
4. Define limitation of access times (up to 8 schedules)
5. Define the Time-Driven events (up to 20)

NOTE: Temporary schedules are programmed using #81 Menu Mode.

Use #80 Scheduling Menu Mode to perform the following functions:

6. Program the time windows
7. Program the open/close schedules
8. Program the Time-Driven events
9. Program the access schedules

Scheduling Menu Structure

To program schedules, enter Scheduling Program Mode: **Installer Code + [#] + [80]**. (Installer or Master level user code.)



Scheduling Program Mode can be entered only when all partitions are disarmed.

PROMPT	EXPLANATION
Access Sched. ? 1 = YES 0 = NO 0	Enter 1 to program access schedules. Refer to <i>Limitation of Access Schedules Programming</i> later in this section for detailed procedures. Enter 0 to move to the “Quit?” prompt.
Quit ? 1 = YES 0 = NO 0	Enter 1 to quit <i>#80 Scheduling Menu Mode</i> and return to normal operating mode. Enter 0 to make any changes or review the scheduling programming options. If you press 0 , the “Time Window?” prompt is displayed.

Time Windows

The system provides 20 time windows that are defined with start and stop times. These windows are used for various open/close and access schedules, as well as for output controls, and are the basis of the scheduling system. These windows are shared among all 8 partitions.

Time Windows Worksheet

The following worksheet is an example of the worksheet found in the *Programming Guide*. This worksheet will help you define time windows and scheduling aspects of this system before you program them. Note that time windows **can** span midnight; for example, from 11 PM to 1 AM.

Time Window Number	Start Time (HH:MM)	Stop Time (HH:MM)
1		
2		
3.....20		

A time window must have a start and a stop time.

Time Windows Programming

Enter Scheduling Mode by entering **Installer Code + [#] + [80]**. The keypad displays the *Time Window Programming* prompt.

PROMPT	EXPLANATION
Time Window ? 1 = YES 0 = NO 0	Enter 1 at this main menu prompt to program time windows.
Time Window # ? 01-20, 00 = Quit 01	Enter the 2-digit time window number (01-20) to be programmed. Press [*] to accept the entry. Enter 00 + [*] at the “Time Window #?” prompt to quit time window programming and display the “Quit ?” prompt.
01 TIME WINDOW 00:00AM 00:00AM	If you entered a time window number, the cursor is now positioned on the tens of hours digit of the start of window entry. Enter the desired start of window hour and press [*]. The cursor moves to the minutes position. Enter the desired minutes and press [*]. Toggle the AM/PM indication by pressing any key 0-9 while the cursor is under the A/P position and then press [*]. Repeat this to program the stop of window entry. When the entry is completed, the “Time Window #?” prompt is displayed again. Enter the next time window number to be programmed and repeat the procedure.
Quit ? 1 = YES 0 = NO 0	Enter 0 at the Quit ? prompt to return to the main menu choices and continue programming. Enter 1 to quit Scheduling Menu Mode.



Because the time windows are shared among all partitions, it is important to make sure that changing a time window does not adversely affect desired actions in other partitions.

Daily Open/Close Schedules

Each partition can be assigned one daily open/close schedule, plus a holiday schedule. Temporary schedules are programmed separately, using the *#81 Temporary Schedule Menu Mode*. To program additional open/close schedules, see *Time-Driven Events Programming* later in this section for the procedure.

Open/Close Schedule Worksheet

The following worksheet is an example of the worksheet found in the *Programming Guide*. Write the previously defined time window numbers for open and close for each partition.

Part	Mon		Tues		Wed		Thur		Fri		Sat		Sun		Hol	
	Op	Cl	Op	Cl	Op	Cl	Op	Cl	Op	Cl	Op	Cl	Op	Cl	Op	Cl
1																
2																
3...8																

Open/Close Schedule Programming

After entering Scheduling Menu Mode, press [0] until the “O/C Schedules?” prompt appears.

PROMPT	EXPLANATION
O/C Schedules ? 1 = YES 0 = NO 0	Enter 1 to program opening and closing schedules.
Partition # ? 01-08, 00 = Quit 01	Enter the appropriate partition number for which the following open/close schedules will apply. Enter 00 + [*] at the “Partition #?” prompt to quit open/close schedules programming and display the “Quit ?” prompt.
Mon P1 OP WIND.? 00:00 00:00 00	Enter the time window number 01-20 for the displayed day’s opening schedule beginning with Monday. Enter 00 if no schedule is desired for a particular day. As the number is keyed in, the actual time that has been stored for that window number is displayed as a programming aid. Press [*] to accept the entry.
Mon P1 CL WIND.? 00:00 00:00 00	Enter the time window number for the displayed day’s closing schedule. As the number is keyed in, the actual time that has been stored for the window number is displayed. Press the [*] key to accept the entry.
Tue P1 OP WIND.? 00:00 00:00 00	The keypad now prompts for Tuesday’s open/close schedule. Follow the procedure for Monday’s prompts. When the last day of the week has been programmed, the holiday opening and closing window prompts are displayed.
Hol P1 OP WIND.? 00:00 00:00 00	Repeat the procedure for the holiday opening and closing time windows. Press the [*] key to accept the entry. When the entries are completed, the “Partition #?” prompt is displayed again. Repeat this procedure for each partition in the system.
Quit ? 1 = YES 0 = NO 0	Enter 0 at the “Quit ?” prompt to return to the main menu choices and continue programming. Enter 1 to quit Scheduling Menu Mode.

Holiday Schedules

A holiday schedule overrides the regular daily open/close schedule on the programmed holidays throughout the year.

The system provides up to 16 holidays that can be assigned for the system. Each holiday can be assigned to any combination of partitions. List the desired holidays in a Month/Day format on the worksheet. Check the partitions for which these holidays apply.

Holiday Schedule Worksheet

The following worksheet is an example of the worksheet found in the *Programming Guide*.

HOL	Partition								
	Month/Day	1	2	3	4	5	6	7	8
1	/								
2	/								
3...16									

Holiday Schedule Programming

After entering Scheduling Menu Mode, press [0] until the “Holidays ?” prompt appears.

PROMPT	EXPLANATION
Holidays ? 1 = YES 0 = NO 0	Enter 1 to program holiday schedules.
HOLIDAY NUMBER ? 01-16,00=Quit 01	Enter the 2-digit holiday number (01-16) to be programmed and press [*] to accept entry. Enter 00 + [*] at the “Holiday Number?” prompt to quit the holiday menus and display the “Quit ?” prompt.
01 ENTER DATE 00/00	The cursor is now positioned on the tens of months digit. Enter the appropriate month, then press [*] to proceed to the day field. Enter the appropriate day for the holiday. Press [*] to accept the entry.
Part ? 12345678 Hit 0-8 x x	Holidays can be set for any partition, as follows. Press [0] to turn all partitions on or off, or use keys 1-8 to toggle the letter “x” under the partition to which this holiday will apply. Press the [*] key when all desired partitions have been assigned. The “Holiday Number?” prompt is displayed again. Repeat the procedure for each holiday to be programmed.
Quit ? 1 = YES 0 = NO 0	Enter 0 at the “Quit ?” prompt to return to the main menu choices and continue programming. Enter 1 to quit Scheduling Menu Mode.

Time-Driven Events

These schedules are used to activate outputs, bypass zones, etc. based on time. There are 20 of these schedules that may be programmed for the system, each governed by the previously defined time windows.

The actions that can be programmed to automatically activate at set times are: relay commands, arm/disarm commands, zone bypassing commands, and open/close access conditions.

Time-Driven Events Worksheet

The following worksheet is an example of the worksheet found in the *Programming Guide*. Fill out the worksheet using the steps outlined below.

Sched Num.	Time Window	Days								Action Desired	Action Specifier	Activation Time
		M	T	W	T	F	S	S	H			
1												
2												
3...20												

1. **Enter the schedule number (01-20) and time window number (01-20)**, and note the day of the week the action is desired.
2. **Enter the code for the desired action and action specifier.** The action codes represent the events that are to take place when the scheduled time is reached. Each action also requires an action specifier, which defines what the action will affect (relay, relay group, partition, zone list, user group). The action specifier varies, depending on the type of action selected.

Automatic Refresh Feature

The system automatically updates the status of all Time-Driven Events upon any of the following occurrences:

- Changing of the time or date via #63 mode
- Exiting #80 Scheduling Menu mode
- Exiting Program mode
- After a disconnect from the downloader
- On a power-up
- At Daylight Saving Time adjustment.

The following is a list of the Action Codes (desired actions) used when programming Time-Driven events. Note that these codes are independent of the relay codes programmed during *Output Programming* in the #93 Menu Mode.

Relay Commands

Action Code	Action	Action Specifier
01	Relay On	Relay #
02	Relay Off	Relay #
03	Relay Close for 2 seconds	Relay #
04	Relay Close XX minutes (set in field 1*74)	Relay #
05	Relay Close YY seconds (set in field 1*75)	Relay #
06	Relay Group On	Relay Group #
07	Relay Group Off	Relay Group #
08	Relay Group Close for 2 seconds	Relay Group #
09	Relay Group Close XX minutes (set in field 1*74)	Relay Group #
10	Relay Group Close YY seconds (set in field 1*75)	Relay Group #

Arm/Disarm Commands

Action Code	Action	Action Specifier
20	Arm-STAY	Partition(s)
21	Arm AWAY	Partition(s)
22	Disarm	Partition(s)
23	Force Arm STAY (Auto-bypass faulted zns)	Partition(s)
24	Force Arm AWAY (Auto-bypass faulted zns)	Partition(s)
25	Arm INSTANT	Partition(s)
26	Arm MAXIMUM	Partition(s)



- The auto-arm warning (field 2*06) applies when using Time-Driven events to auto-arm.
- Temporary schedules do not override an auto-arming or auto-disarming programmed in Time-Driven events.
- The auto-arming window cannot be extended using the Installer Code + #82 Mode.

Bypass Commands

Action Code	Action	Action Specifier
30	Auto bypass – Zone list	Zone list #
31	Auto unbypass – Zone list	Zone list #

Open/Close Windows

Action Code	Action	Action Specifier
40	Enable Opening Window by partition	Partition(s)
41	Enable Closing Window by partition	Partition(s)
42	Enable Access Window for access group	Access Group
50	Off-Normal Reminder (starts local keypad beeping if fire or system trouble condition exists)	None

Access Control Commands

Action Code	Action	Action Specifier
55	Access Point Grant	Access Point #
56	Access Point Grant with Override	Access Point #

Action Code	Action	Action Specifier
57	Access Point Protect	Access Point #
58	Access Point Bypass	Access Point #
59	Access Point Lock	Access Point #
60	Access Point Exit	Access Point #
61	Access Point Group Grant	Group #
62	Access Point Group Grant with Override	Group #
63	Access Point Group Protect	Group #
64	Access Point Group Bypass	Group #
65	Access Point Group Lock	Group #
66	Access Point Group Exit	Group #
67	Access Point Partition Grant	Partition #
68	Access Point Partition Grant with Override	Partition #
69	Access Point Protect by Partition	Partition #
70	Access Point Bypass by Partition	Partition #
71	Access Point Lock by Partition	Partition #
72	Access Point Exit by Partition	Partition #
73	Access Point Trigger On	Trigger #
74	Access Point Trigger Off	Trigger #
77	Access Point Group Enable	Group #
78	Access Point Group Disable	Group #

3. **Enter the desired activation time** (when the action is to take place). Select from:

Activation Time	Description
1	Beginning of time window.
2	End of time window.
3	During time window active period only (on at beginning of window, off at end). For example, if bypass is selected to activate during the window, zones in a zone list are bypassed at the beginning of the window and unbypassed at the end of the window.
4	Beginning and end of time window (e.g., a coffee break buzzer). In this example, if relay pulse is selected, the relay pulses for 2 seconds at the beginning of the window, signaling the beginning of the coffee break. At the end of the window it pulses again, signaling the end of coffee break.
5	Random time at the start of the time window (occurs within 30 minutes after the start of the time window). NOTE: Since the randomization for choice "5" occurs within 30 minutes after the start of the window, the time window must be of a duration of at least 30 minutes.
6	Random time at the end of the time window (occurs within 30 minutes after the end of the time window).
7	Random during the time window (begins within 30 minutes after the start of the time window and ends within 30 minutes after the end of the time window). NOTE: Since the randomization for choice "7" occurs within 30 minutes after the start of the window, the time window must be of a duration of at least 30 minutes.

Field *04 must be enabled for randomization. A user must initiate a random schedule by entering one of the following sequences:

- **[User Code] + [#] + [41]**. This will randomize, up to 30 minutes, the activation time of all devices, programmed for randomization, assigned to the partition the sequence is entered in. Enter the sequence again to turn off the random schedule.
- **[User Code] + [#] + [42]**. This is the same as the method above, except the randomization occurs only on devices with activation times within 6 PM and 5 AM. Enter the same sequence again to turn off the random schedule.

Time-Driven Event Programming

The following menu items must first be programmed in *Output Programming in the #93 Menu Mode*:

Enter Relay No.	(reference identification number)
Output Group	(if applicable)
Restriction	
Output Type	(V-Plex, 4204/4204CF, or FSA)
Zone No.	(V-Plex)
ECP Address	(4204/4204CF or FSA)
Relay No.	(4204/4204CF)
LED No.	(FSA)

UL You must not program Random Scheduling of Time Driven Events for UL installations.

After entering Scheduling Menu Mode, press [0] until the “Timed Events ?” prompt appears.

PROMPT	EXPLANATION
--------	-------------

Timed Events ? 1 = YES 0 = NO 0	Enter 1 to program timed events.
---	----------------------------------

TIMED EVENT # ? 01-20, 00=Quit 01	Enter the timed event number to be programmed (01-20). Press [*]. The system then prompts the user to enter the desired action to be taken. Enter 00 at the “TIMED EVENT #?” prompt to quit the timed event menus and display the “Quit ?” prompt.
--------------------------------------	---

01 ACTION ? none 00	Enter the action code for this timed-event number from the list at the left. This could be an output command, an arming command, or any other Time-Driven event. Press [*] to accept the entry. The prompt for the action specifier appears.
---	---

ACTION CODES	EXPLANATION	ACTION SPECIFIER
--------------	-------------	------------------

01=Relay On 02=Relay Off 03=Relay Close for 2 seconds 04=Relay Close XX minutes 05=Relay Close YY seconds	Actions 01-05 If you selected actions 01-05 , the prompt at the right appears. Enter the relay number. Press [*] to accept entry. The “Time Window ?” prompt appears.	01 RELAY # ? 00
---	---	------------------------

06=Relay Group On 07=Relay Group Off 08=Relay Group Close for 2 seconds 09=Relay Group Close XX minutes 10=Relay Group Close YY seconds	Actions 06-10 If you selected actions 06-10 , the prompt at the right appears. Enter the relay group number. Press [*] to accept entry. The “Time Window ?” prompt appears.	01 RELAY GRP # ? 00
---	---	----------------------------

20=Arm-STAY 21=Arm AWAY 22=Disarm 23=Force Arm STAY 24=Force Arm AWAY 25=Arm INSTANT 26=Arm MAXIMUM 40=Enable Open Window by Part. 41=Enable Close Window by Part.	Actions 21-26 and 40-41 If you selected actions 21-26 or 40-41 , the prompt at the right appears. Enter the partition to which the action applies. Enter 0 to select all partitions. Enter a partition number again to deselect it. Press [*] to accept entry. The “Time Window ?” prompt appears.	PART? 12345678 HIT 0-8 X X
--	---	-------------------------------

ACTION CODES	EXPLANATION	ACTION SPECIFIER
30=Auto bypass – Zone list 31=Auto unbyypass – Zone list	<p>Actions 30-31</p> <p>If you selected actions 30-31, the prompt at the right appears. Enter the zone list number that contains the zones to be bypassed or unbyypassed.</p> <p>Press [*] to accept entry. The “Time Window ?” prompt appears.</p>	<div style="border: 1px solid black; padding: 2px;"> 01 ZONE LIST ? ENTER 01-15 01 </div>
42=Enable Access Window for Access group(s)	<p>Action 42</p> <p>If you selected action 42, the prompt at the right appears. Enter the group number to which the time window will apply.</p> <p>Press [*] to accept entry. The “Time Window ?” prompt appears.</p>	<div style="border: 1px solid black; padding: 2px;"> GROUP ? 12345678 HIT 0-8 X </div>
50=Off-Normal Reminder	<p>Action 50</p> <p>No action specifier is required for this action since the condition that this occurs for are system-wide.</p>	
55=Access Point Grant 56=Access Point Grant w/Override 57=Access Point Protect 58=Access Point Bypass 59=Access Point Lock 60=Access Point Exit	<p>Actions 55-60</p> <p>If you selected actions 55-60, the prompt at the right appears. Enter the access point number.</p> <p>Press [*] to accept entry. The “Time Window ?” prompt appears.</p>	<div style="border: 1px solid black; padding: 2px;"> 01 ACCESS POINT # 000 </div>
61=Access Point Group Grant 62=Access Point Group Grant w/Override 63=Access Point Group Protect 64=Access Point Group Bypass 65=Access Point Group Lock 66=Access Point Group Exit 77=Access Point Group Enable 78=Access Point Group Disable	<p>Actions 61-66 and 77-78</p> <p>If you selected actions 61-66, the prompt at the right appears. Enter the group number.</p> <p>Press [*] to accept entry. The “Time Window ?” prompt appears.</p>	<div style="border: 1px solid black; padding: 2px;"> 01 GROUP # 00 </div>
67=Access Point Partition Grant 68=Access Point Partition Grant w/Override 69=Access Point Protect by Partition 70=Access Point Bypass by Partition 71=Access Point Lock by Partition 72=Access Point Exit by Partition	<p>Actions 67-72</p> <p>If you selected actions 67-72, the prompt at the right appears. Enter the partition to which the action applies. Enter 0 to select all partitions. Enter a partition number again to deselect it.</p> <p>Press [*] to accept entry. The “Time Window ?” prompt appears.</p>	<div style="border: 1px solid black; padding: 2px;"> PART? 12345678 HIT 0-8 X X </div>
73=Access Point Trigger On 74=Access Point Trigger Off	<p>Actions 73-74</p> <p>If actions 73-74 were selected, the prompt at the right will be displayed. Enter the trigger number.</p> <p>Press [*] to accept entry. The “Time Window ?” prompt appears.</p>	<div style="border: 1px solid black; padding: 2px;"> 01 TRIGGER # 00 </div>
PROMPT	EXPLANATION	
<div style="border: 1px solid black; padding: 2px;"> 01 Time Window ? 00:00 00:00 01 </div>	<p>Enter the time window number (01-20) for which this timed event is to occur. As the number is keyed in, the actual time that has been stored for the time window number is displayed.</p> <p>Press [*] to accept entry.</p>	

PROMPT	EXPLANATION
01 Active time ? 0	Enter the activation time from 1-10 (listed below). As the number is keyed in, the activation time is displayed. The choices are: 1: Trigger at the start of the window. 2: Trigger at the end of the window. 3: Take effect only for the duration of the window. 4: Trigger at both the start and the end of the window. Example: coffee break buzzer. 5: Random trigger, up to 30 minutes, after the start of the window. 6: Random trigger, up to 30 minutes, after the end of the window. 7: Take effect only for the duration of the window, but random start and end the window up to 30 minutes. Press [*] to accept entry.
Days ? MTWTFSSH Hit 0-8 x x	The system then asks for which days the event is to be activated. Press 0 to toggle all days on or off; or press keys 1-8 to toggle the letter “x” under the day on or off (Monday = 1, Holiday = H = 8). When all entries have been made, the “TIMED EVENT #?” prompt is displayed again. Repeat the procedure for each timed event for the installation.
Quit ? 1 = YES 0 = NO 0	Enter 0 at the “Quit ?” prompt to return to the main menu choices and continue programming. Enter 1 to quit Scheduling Menu Mode.

Limitation of Access Schedules

Limitation of Access is a means by which a user’s access code is limited to working during a certain period of time. The system provides 8 Access Schedules, each of which consists of two time windows for each day of the week and two time windows for holidays (typically, one for an opening time window and the second for a closing time window). A user, required to follow a schedule, would be assigned to an access group of the same number (e.g., schedule 1= group 1).

The user’s access code is assigned to a group when that user is added to the system. If no limitations apply, enter **0**.

Limitation of Access Schedule Worksheet

Enter the appropriate time window numbers for each access schedule.

Acc Sch	Mon		Tues		Wed		Thurs		Fri		Sat		Sun		Hol	
	W1	W2	W1	W2	W1	W2	W1	W2	W1	W2	W1	W2	W1	W2	W1	W2
1																
2																
3...8																

NOTE: The holidays used for the access groups are the same as those defined in the holiday schedule.

Limitation of Access Schedules Programming

To program access schedules enter Scheduling Menu Mode **Installer Code + # 80**. After entering Scheduling Menu Mode, press [0] until the “Access Sched. ?” prompt appears.

PROMPT	EXPLANATION
Access Sched. ? 1 = YES 0 = NO 0	Enter 1 to program access schedules.
ACCESS SCHED # ? 01-08, 00 = Quit 01	Enter the access control schedule number between 01 and 08 . Press [*] to accept entry. Enter 00 at the “Access Sched #?” prompt to quit the access control menus and display the Quit ? prompt.

PROMPT	EXPLANATION
MON A1 Window 1 ? 00:00 00:00 00	Enter the first time-window number (01-20) for this access schedule for the displayed day. As the number is keyed in, the actual time that has been stored for the window is displayed. Press [*] to continue.
MON A1 Window 2 ? 00:00 00:00 00	Enter the second time-window number from 01-20 for this access schedule for the displayed day. As the number is keyed in, the actual time that has been stored for the window is displayed. Press [*] to continue.
TUE A1 Window 1 ? 00:00 00:00 00	Repeat the procedure for the other days of the week. When the last day of the week has been programmed, the windows for holidays may be entered.
Hol A1 Window 1 ? 00:00 00:00 00	Enter the first time-window number for holidays for this access schedule. As the number is keyed in, the actual time that has been stored for the window is displayed. Press [*] to continue.
Hol A1 Window 2 ? 00:00 00:00 00	Enter the second time-window number for holidays for this access schedule. As the number is keyed in, the actual time that has been stored for the window is displayed. Press [*] to continue.
Quit ? 1 = YES 0 = NO 0	Enter 0 at the "Quit ?" prompt to return to the main menu choices and continue programming. Enter 1 to quit Scheduling Menu Mode.

Temporary Schedules

Each partition can be assigned a temporary schedule, which overrides the regular open/close schedule (and the holiday schedule). This schedule takes effect as soon as it is programmed, and remains active for up to one week.

Only users with the authority level of manager or higher can program temporary schedules.

A temporary schedule affects only the partition from which it is entered. Temporary schedules can also be reused at later dates simply by scrolling (pressing [#]) to the "DAYS?" prompt and activating the appropriate days. This should be considered when defining daily time windows.

Temporary Schedule Worksheet

Partition/Windows	Mon	Tue	Wed	Thu	Fri	Sat	Sun
1 Disarm Window							
Start Time HH:MM							
Stop Time HH:MM							
Arm Window							
Start Time HH:MM							
Stop Time HH:MM							
2...8 Disarm Window							
Start Time HH:MM							
Stop Time HH:MM							
Arm Window							
Start Time HH:MM							
Stop Time HH:MM							

Temporary Schedules Programming

Enter **User Code + [#] + 81** to enter this mode.

PROMPT	EXPLANATION
Mon DISARM WIND. 00:00AM 00:00AM	<p>This prompt is for entering the start and end times of the disarm (opening) window for Monday. Upon entry of this mode, the cursor is positioned on the tens of hours digit of the start time of the disarm window. Enter the desired hour.</p> <p>Press [*] to move to the minutes field. The minutes are entered in the same manner.</p> <p>Press [*] to move to the AM/PM position. Pressing any key in the 0-9 range toggles the AM/PM indication. Repeat the procedure for the stop time entry.</p> <p>Press [*] to store the entries and move to the arming (closing) window for Monday.</p> <p>Pressing [#] scrolls you through the prompts without making any changes.</p>
Mon ARM WINDOW 00:00AM 00:00AM	<p>This prompt is for entering the start and end times of the arm (closing) window for Monday. The cursor is positioned on the tens of hours digit of the start time of the arm window. Enter the hour.</p> <p>Press [*] to move to the minutes field. The minutes are entered in the same manner.</p> <p>Press [*] to move to the AM/PM position. Pressing any key in the 0-9 range toggles the AM/PM indication. Repeat the procedure for the stop time entry.</p> <p>After the windows for that day have been completed, the system prompts for disarm and arm time windows for the next day.</p> <p>Press [#] if no changes are desired.</p>
Tue DISARM WIND. 00:00AM 00:00AM	<p>Repeat the procedure described above for all days of the week.</p> <p>When all the windows for all the days have been completed, the system prompts for which days of the schedule are to be activated.</p>
Days ? MTWTFSS Hit 0-7 x x	<p>This is the prompt that actually activates the temporary schedule.</p> <p>To select the days to be activated, enter 1-7 (Monday = 1). An "X" appears under that day, indicating the temporary schedule for that day is active. Entering a day's number again deactivates that day. Pressing 0 toggles all days on/off.</p> <p>The temporary schedule is in effect only for the days highlighted with the letter "x" under them. As the week progresses, the selected days are reset to the inactive state, but all other entries for the temporary schedule remain programmed.</p> <p>Press [*] to store the entries or press [#] to exit the Temporary Schedule Entry Mode without making any changes.</p>

User Scheduling Menu Mode

The system provides up to 20 "timers" available to the end user to control output devices. The output devices themselves are programmed into the system by the installer during *Output Programming* in the #93 Menu Mode. The end user needs only to know the output device number and its alpha descriptor.

The installer may set certain outputs to be "restricted" during *Output Programming* (this prevents the end user from controlling doors, pumps, Notification Appliance Circuits, etc.)

To enter this mode, the user enters **User Code + [#] + 83**.

PROMPT	EXPLANATION
Output Timer # ? 01-20, 00=Quit 01	<p>Enter the output timer number to be programmed (01-20). Press [*] to accept entry and move to the next prompt.</p> <p>Enter 00 to quit and return to normal operating mode.</p>
06 07:00P 11:45P PORCH LITE 04	<p>If that timer number has already been programmed, a summary screen appears. In this example:</p> <p>06 = Timer # 07:00PM = Start Time 11:45PM = Stop Time PORCH LITE = Descriptor for Output Device # 4 04 = Output Device # affected by this timer</p> <p>Press [*] to continue.</p>

PROMPT	EXPLANATION
06 ENTER OUTPUT# PORCH LITE 04	Enter the desired output number (01-96). As the number is entered, the descriptor for that output device is displayed. Press [*] to continue.



Entering **00** as the output number deletes the timer (Timer 06, in this example) and displays an output descriptor of "None." Output devices are programmed via #93 Menu Mode.

PROMPT	EXPLANATION
06 ON TIME ? 07:00 PM	The cursor is positioned on the tens of hours digit of the ON time. Enter the desired hour. Press [*] to move to the minutes field. The minutes are entered in the same manner. The AM/PM indication is toggled by hitting any key from 0-9 while the cursor is under the AM/PM position. Press [*] to continue.
06 OFF TIME ? 11:45 PM	The cursor positioned on the tens of hours digit of the OFF time. Enter the desired hour. Press [*] to move to the minutes field. The minutes are entered in the same manner. The AM/PM indication is toggled by hitting any key in the 0-9 range while the cursor is under the AM/PM position. Press [*] to continue.
06 DAYS? MTWTFSS HIT 0-7 x x	To select the days to be activated, enter 1-7 (Monday = 1). An "x" appears under that day, indicating the output for that day is active. Entering a day's number again deactivates that day. Pressing 0 toggles all days on/off. The outputs are in effect only for the days highlighted with the letter "x" under them. As the week progresses, the selected days are reset to the inactive state, unless the permanent option is selected (next screen prompt). When completed, press [*] to continue.
06 Permanent ? 0 = NO, 1 = YES 0	Selecting "Permanent" (1) means that this schedule will be in effect on a continuous basis. Selecting 0 means that this schedule will be in effect for one week only. The letter "x" under the day is then cleared, but all other entries for the output device remain programmed. Press [*] to accept entry. The system quits User Scheduling Mode and returns to normal operating mode.

Downloading Primer

(Remote Downloading is not a UL Listed feature)

General Information

Downloading allows the operator to remotely access, program, and control the security system over normal telephone lines. Anything that can be done directly from the keypad can be done remotely, using COMPASS downloading software. To communicate with the control panel, the following is required:

1. IBM PC-compatible 486 33MHz PC or better with 100 MB of available hard disk space and at least 8MB of RAM (12MB is preferred). Windows 3.X, Windows 95, 98, or Windows NT.
2. One of the following modems:
 - ADEMCO CIA
 - Hayes Smartmodem 1200 (external: level 1.2 or higher; internal: level 1.1 or higher)
 - Hayes Optima 24 + Fax 96 external
 - Hayes Optima 336
 - BizComp Intellimodem 1200 w/volume
 - BizComp Intellimodem 2400

Other brands are not compatible, even if claimed to be 100% compatible.

3. COMPASS DOWNLOADING software available on CD ROM with a complete User's Manual. It may also be downloaded from the ADEMCO web page. The web address is <http://www.ademco.com>.



Internal modems must have a 4-position DIP switch. Modems with a 6-position DIP switch will not work.

Access Security

The following four levels of protection guard the control against compromise while it is being accessed from a remote location:

1. Security code handshake: The subscriber's account number as well as an 8-digit ID number (known only to the office) must be matched between the control and computer.
2. Hang-up and callback: The control panel "hangs up" and calls the computer back at the pre-programmed number only if the security codes match.
3. Data encryption: All data that is exchanged between the computer and control is encrypted to reduce the possibility of anyone "tapping" the line and corrupting data.
4. Operator access levels: Operators may be assigned various levels of access to the downloader, each having its own log-on code. The access levels allow the operators read/write capabilities of the customers' account information. For a detailed explanation of the access levels, see the downloading software User Manual.

NOTES:

- Each time the control panel is accessed successfully, a Callback Requested report is sent to the central station, if Opening reports are programmed.
- When the system is downloading, the keypad displays "MODEM COMM."
- After each download or save, an automatic time stamp is done, to indicate the last download (or save) and the operator ID number.
- A complete hard copy of each individual account can be obtained by connecting a printer to the computer. Refer to your computer Owner's Manual or contact your dealer for printer recommendations.

Unattended Download

Unattended download allows the control panel to communicate with the download computer without an operator at the computer. This feature is useful on new installations.

The installer can mount the control, attach a keypad and phone line, and continue to wire the rest of the installation while the system is automatically downloaded.

The following items must be programmed for unattended download:

- The account number (field *32)
- Primary central station telephone number (field *33)
- The download telephone number (field *35)
- Unattended Mode (enable in field *54.)

NOTE: The default for field *54 is enabled (1).

Installer Unattended Program Mode

The Installer Unattended Program Mode allows the installer to program fields *32, *33, and *35 without entering the normal program mode.

Press 0 (NO) or 1 (YES) in response to the displayed menu selection. Pressing 0 displays the next choice in sequence.

To access this mode, enter **Installer Code + [#] + [89]**. The following prompt appears:

PROMPT	EXPLANATION
Unattend. Phone 1 = YES 0 = NO 0	Press 1 to enter the unattended phone number.
Unattend. Phone 1	Enter the telephone number of the download software modem. Enter up to 17 digits, 0-9 ; A key = * , B key = # , C key = 2-Sec. Pause . Do not fill unused spaces. Press the * key to accept the phone number and exit. Press the # key to exit without changing any data. The system displays the Quit menu prompt. Press 1 to exit the Installer Unattended Program Mode, or 0 to continue to the next prompt.
Unattended Acct# 1 = YES 0 = NO 0	Press 1 to enter the unattended account number.
Unattended Acct# 15-15-15-15	Enter a 3- or 4-digit (depending on report format) account number 00-09 ; B-F (11-15) . Each number requires a 2-digit entry so as to allow entry of hexadecimal digits (B-F). If a 3-digit account number is to be used, enter digits in the first 3 locations, and enter 00 in the last location. Press the * to exit without changing any data. The system displays the Quit menu prompt. Press 1 to exit, or 0 to continue.
Primary Phone 1 = YES 0 = NO 0	Press 1 to enter the primary phone number.
Primary Phone 0	Enter the primary central station telephone number. Enter up to 17 digits, 0-9 ; A key = * , B key = # , C key = 2-Sec. Pause . Do not fill unused spaces. Press the D key accept the phone number and exit. Press the * to exit without changing any data. The system displays the Quit menu prompt. Press 1 to exit, or 0 to continue.
Quit ? 1 = YES 0 = NO 0	Enter 1 to quit the Installer Unattended Program Mode. Enter 0 at the "Quit ?" prompt to return to the first menu prompt, "UNATTEND. PHONE".
Trig. Unattended 1 = YES 0 = NO 0	Enter 1 to initiate the unattended download at this time. Otherwise enter 0. NOTE: The Compass Downloader must be in Unattended Mode.

An unattended download may be initiated by the installer or end user at any time by entering **User Code + [#] + [1]**.

Getting On-Line with a Control Panel

At the protected premises, the control panel must be connected to the existing telephone line (refer to the *SECTION 3: Installing the Control*). No programming of the panel is required before downloading to an initial installation unless you are performing an unattended download.

When establishing a connection between the computer and the control panel, the following occurs:

Stage	What Happens
1	The computer calls up the control panel. (The phone number for each customer must be entered into the customer's account file on the computer.)
2	The control panel answers the phone call at the pre-programmed ring count and executes a handshake with the computer.

Stage	What Happens
3	The computer sends a request for callback to the control, unless callback is not required.
4	The panel acknowledges the request and hangs up. During the next few seconds, the control processes the request, making sure certain encrypted information received from the computer matches its own memory.
5	Upon a successful match, the control panel seizes the phone line and calls the computer back, unless callback is not required. (The phone number to which the computer's modem is connected must be programmed into the control field *35.)
6	The computer answers, usually by the second ring, and executes a handshake with the panel.
7	The panel then sends other default information to the computer. If this information matches the computer's information, a successful link is established. The system is now "on-line" with the computer.



- Alarms and Trouble responses and reports are disabled during actual uploading or downloading sessions. If you are on-line, but not actively uploading or downloading, all alarms report immediately. All other reports are delayed until you complete the session.
- The keypads remain active when on-line with a control, but are inactive during actual uploading or downloading sessions.

To download a control without programming any information, perform the following steps:

Step	Action
1	Enter the Installer Code + [#] + [5] . The panel temporarily enables a ring count of 5 and sets the Download Callback option to "1" (callback not required).
2	From the computer, call the panel using the downloader software set to "First Communication" Mode. The downloader establishes a session with no callback. The panel information can then be downloaded.

On-Line Control Functions

The following functions can be performed while on-line with a control panel (see field *37):

- Arm the system in the AWAY Mode; disarm the system
 - Bypass a zone
 - Force the system to accept a new program download
 - Shut down communication (dialer) functions (for nonpayment of monitoring fees in an owned system)
 - Shut down all security system functions (for nonpayment for a leased system)
 - Inhibit local keypad programming (prevents takeover of your accounts)
 - Leave a message for customer
- NOTE:** Messages sent to the control panel from the downloader will be viewable at ALL partitions.
- Command the system to upload a copy of its resident program to the office
 - Read: arming status, AC power status, list of faulted zones, list of bypassed zones, 1024 event log, list of zones currently in alarm, list of zones currently in trouble, and ECP equipment list
 - Set the real-time clock

Scheduled Download

The FA1700C can be programmed to periodically and automatically call the downloader. When this option is set up, the system will call the downloader at a scheduled time. Once the connection is established with the modem, the downloader controls which functions are performed (download, arm, upload event log, etc.).

The programmable options for the scheduled download are located in the #93 Menu Mode in the *Programming Guide* under the main menu prompt *Scheduled Check-in*.

The options are as follows:

- Check-in interval (weekly, monthly quarterly, yearly)
- Quarter of the year (if quarterly is selected)
- Month of the year (if monthly, quarterly, or yearly is selected)
- Day of the month (if monthly, quarterly, or yearly is selected)
- Day of the week (if weekly is selected)
- Time of day

Refer to the #93 Menu Mode in the *Programming Guide* for sequence of the prompts.

Direct-Wire Downloading

The FA1700C can be downloaded without using a modem or telephone line by using a 4100SM Serial Module and Compass Downloading Software. The direct-wire downloading connection is to be temporary, and is not part of the permanent installation. Direct-wire downloading is meant as a tool for the installer during the installation process.

Connector J2 on the main PC board (see the *Summary of Connections* diagram on the inside back cover of this manual) is intended to be interfaced to either a local serial printer (see *Event Log Connections* in *SECTION 3 Installing the Control*) or a computer. Make connections to a computer as shown below. **Note that the violet wire connection for a computer differs from that used when connecting a serial printer.**



The connections between the control and the 4100SM are different than those shown in the 4100SM Installation Instructions. See Figure 7-1 for the correct connections. In addition, in place of the green wire, referred to in step 2 of the "IN CASE OF DIFFICULTY" section of the 4100SM Instructions, use the violet wire instead.



Remove the VA8201 Alpha Pager Module, if it is installed, before performing the direct-wire download. It may be reconnected once the direct-wire download is completed.

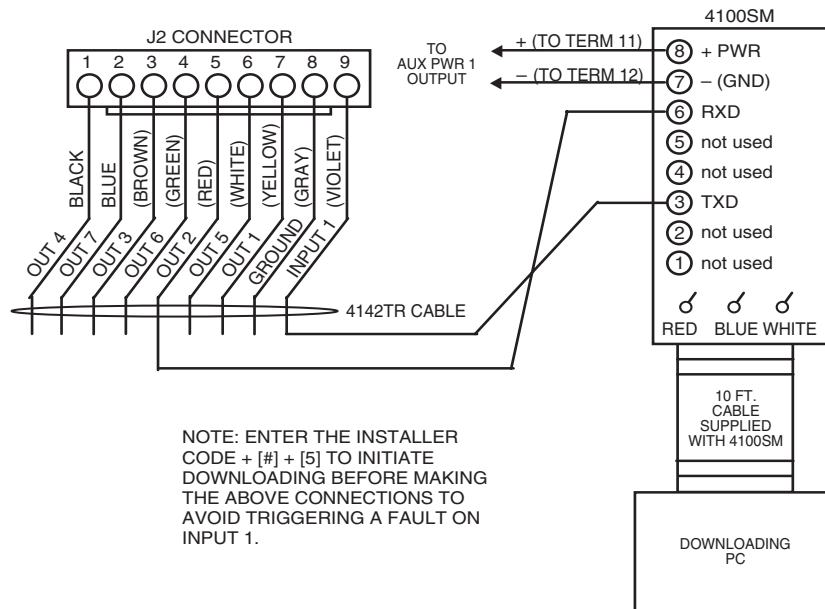

Figure 7-1: Direct-Wire Downloading Connections

Telco Handoff

Telco handoff is another method of getting on-line with the downloader. The installer or customer enters the **User Code + [#] + [1]**, while on the phone line with the computer's modem phone line. The customer will get cut-off and the panel and download computer will establish a connection.

Setting the Real-Time Clock

General Information

This system provides a real-time clock, which must be set in order for the system's event log to keep track of events by time and date. It must also be set in order to execute scheduling programs (Time-Driven events). If you are using Panel Linking, you can set the Real-Time clock at one panel and have the system automatically update the time and date at the other control panels.



Use a FA560KP alpha keypad to set the real-time clock, or set the clock via the downloader software. Only users with Installer or Master authority level can set the clock.

Setting the Time and Date

To set the real time clock, perform the following steps:

Step	Action
1	Enter Installer or Master Code + [#] 63 . Typical display shows: <div style="border: 1px solid black; padding: 5px; width: fit-content; margin: 5px 0;"> TIME/DATE — THU 12:01 AM 01/01/90 </div> The day of the week is automatically calculated based on the date entered. Time and date entries are made by simply entering the appropriate hour, minute, month, day and year. Press [*] to move the cursor to the right of the display, to the next position. Press [#] to move the cursor to the left of the display, to the previous position.
2	Enter the correct hour. Then press [*] to move to the "minutes" field.
3	Enter the correct minutes. Press [*] to move to the AM/PM position.

Step	Action
4	Press any key 0-9 to change AM to PM, or PM to AM. Press [*] to move cursor to the "month" field position.
5	Enter the correct month using a 2-digit entry. Press [*] to move cursor to the "day" field position.
6	Enter the correct day using a 2-digit entry. Press [*] to move cursor to the "year" field position.
7	Enter the correct year. Press [*] to continue.
8	The following display appears: <div style="border: 1px solid black; padding: 5px; width: fit-content; margin: 5px 0;"> Broadcast Time? 1=YES 0=NO 0 </div> If panel linking is being used, enter 1 (YES) to send this time and date setting to all the other panels. Otherwise enter 0 . Press [*] to exit the real-time clock edit mode.

User Access Codes

General Information

The FA1700C allows a total of 250 security access codes to be allocated. Each security access code is identified by a user ID number. **Regardless of the number of partitions each code has access to, it occupies only one user slot in the system. If a particular code is not used in all partitions, that user ID number cannot be used again.**

The Quick Arm feature can also be programmed (partition-specific program field *29). The Quick Arm feature allows the user to arm the system by pressing the [#] key instead of the security code. The security code must always be entered to disarm the system.



- A user code other than the installer code must be programmed in order for the Quick Arm feature to function.
- Users 001-050 are the only users that can perform panel linking and are automatically assigned panel linking access.

The system is shipped with the following defaults for the user codes:

User	4-Digit Code	Alpha Descriptor
User 1 (Installer)	5140	INSTLR
User 2	1234	MASTER

User Codes & Levels of Authority

Each user of the system can be assigned a level of authority, which authorizes the user for certain system functions. A user can have different levels of authority within different partitions

Use the “View Capabilities” keypad function (**User Code + [*] + [*]**) to view the partitions and authority levels for which a particular user is authorized. These levels are described below.

Level 0: Installer (User 1) Code

- Programmed in field *00 (default = 5-1-4-0). Installer Open/Close reporting selected in field *39.
- Can perform all system functions (arm, disarm, bypass, etc.), but **cannot disarm** if armed by another code (or by Quick Arm).
- Can add, delete, or change all other codes, and can select Open/Close reports for any user.
- Is the only code that can be used to enter program mode. The Installer Code can be prevented from re-entering the Program Mode by exiting using *98.
- Must program at least one Master Code during initial installation. Master Codes are codes intended for use by the primary user(s) of the system.

Level 1: Master Codes

- Can perform all normal system functions.
- Can be used to assign up to 148 lower-level codes, which can be used by other users of the system.
- Cannot assign anybody a level of 0 or 1.
- May change his own code.
- Can add, delete, or change Manager or Operator Codes. Each user’s code can be individually eliminated or changed at any time.
- Open/Close reporting is automatically the **same** as that of the Master who is adding the new user.

Level 2: Manager Codes

- Can perform all system functions (arm, disarm, bypass, etc.) programmed by Master.
- May add, delete, or change other users of the system below this level (Manager cannot assign anybody a level of 0, 1, or 2).
- May change his own code.
- Open/Close reporting is automatically the **same** as that of the Manager who is adding the new user.

Levels 3-5: Operator Codes

- Can operate a partition, but cannot add or modify any user code (see table below).

Level	Title	Functions Permitted
3	Operator A	Arm, Disarm, Bypass
4	Operator B	Arm, Disarm
5	Operator C	Arm, Disarm only if armed with same code

- Operator C (sometimes known as the Babysitter Code) cannot disarm the system **unless** the system was armed with that code. This code is usually assigned to persons who may need to arm and disarm the system at specific times only (e.g., a babysitter needs to control the system only when babysitting).

Level 6: Duress Codes

- Sends a silent alarm to a central monitoring station if the user is being forced to disarm (or arm) the system under threat (system must be connected to a central station).
- When the system’s Auxiliary Voltage Triggers are connected to another communication’s media (Derived Channel/Long Range Radio), note that duress is signaled on the same trigger that signals silent panic (whereas duress has its own unique report when digitally communicated).
- Assigned on a partition-by-partition basis, and can be any code or codes desired.



Duress Reporting NOTE: A non-zero report code for zone 992 (duress) must be programmed, and partition-specific field *85 duress location enabled, to enable Duress reporting.

- The Duress report-triggering logic activates on the 5th key depression (such as OFF), not the 4th key depression (last digit of code). Duress reports are not triggered if the 5th key is a [*], such as when you perform a GOTO or view the capabilities of a user.

General Rules on Authority Levels and Changes

The following rules apply to users when making modifications within the system based on the user code authority levels:

- Master Codes and all lower-level codes can be used interchangeably when performing system functions within a partition (a system armed with a user’s temporary code can be disarmed with the Master Code or another user’s temporary code), except the Operator Level C Code described above.
- A user may not delete or change the user code of the SAME or HIGHER authority than that which he is assigned.
- A user (levels 0, 1 and 2 only) may only ADD users to a LOWER authority level.
- A user may assign other users access to only those partitions to which he himself has access.
- A user code can be DELETED or CHANGED only from within the partition it was created in.
- User numbers must be entered in 3 digits. Single-digit user numbers must, therefore, always be preceded by a “00” (e.g., 003, 004, 005, etc.). Make sure the end user understands this requirement. Temporary codes are entered as 4-digit numbers.

Open/Close Reporting Note: When a user is added, the system prompts for Open/Close reporting capability only if the installer is adding the new user. When a Master or Manager adds a new user, the new user’s Open/Close reporting is the same as that of the Master or Manager who is adding the user. If Open/Close reports are required to be selectable by the Master or Manager, the Installer should assign two Master or Manager user codes: one with Open/Close reporting enabled, and one without.

Note that Open/Close reporting of Quick Arm is enabled if User 002 is enabled for Open/Close reporting, and that Quick Arm reports as User 000. In order for Quick Arm reports to be sent for all partitions, User 002 must have authority and Open/Close must be enabled for all partitions. If a code with access to all partitions is not desired, it is suggested that user 002 be assigned authority level 5 in all partitions, and that the code be kept secret. Authority level 5 cannot disarm the system unless armed by that user.



ADEMCO Contact ID format is capable of reporting Users 001-150 uniquely. If any other report format is used, only user numbers 001 – 015 can uniquely report to the central station. Users 016 – 150 will report as User 015.

Multiple Partition Access

Each user is programmed for a primary (home) partition. A user can also be given access to operate one or more additional partitions. Within each partition, each user may be programmed to have different levels of authority. For example, User 003, the VP of Engineering, could be assigned to work within the Engineering Department (Partition 1) of ABC Manufacturing. Because he needs the full capabilities in his area, he is assigned as a MASTER with Level 1 authority.

He must also be able to gain access to the manufacturing area (Partition 2) on an emergency basis. You can set this up easily by requesting that he also be assigned to Partition 2, with a level of authority set lower, such as Level 4 (OPERATOR Level B).

The control automatically assigns him the same user number within Partition 2.

EXAMPLE OF MULTIPLE PARTITION ACCESS

Part 1	Part 2	Part 3	Part 4	Part 5	Part 6	Part 7	Part 8
User 3	User 3						
Level 1	Level 4						
Master	Oper B						

In the above example, User 3 has MASTER authority in Partition 1 and OPERATOR B authority in Partition 2. His user number is the same for both partitions. Note that if a user number is already being used in a partition, the system will automatically assign a new user an unused number. Also notice that no access is allowed for this user into Partitions 3 – 8. Attempts to access these partitions would be denied automatically.

Adding a Master, Manager, or Operator Code



During user code entry, normal key depressions at other keypads in a partition are ignored. However, panic key depression causes an alarm and terminates user entry.



When entering panel link users (001-050) on the local panel, the other remote panels will be prevented from entering panel link user data until the local panel exits User Edit Mode.

Enter **Installer Code† + [8] + new user no. (002-250) + new user's code**

†Or Master or Manager Code, but the code must be a higher level of authority than the code being changed (e.g., a Manager Code can add an Operator-level Code, but cannot add a Master or another Manager Code). Keypad prompts for the authority level for this user.

PROMPT	EXPLANATION
User Number = 003 Enter Auth. Level	Enter the level number as follows: 1 = Master 2 = Manager 3 = Operator Level A 4 = Operator Level B 5 = Operator Level C 6 = Duress Keypad then prompts for Open/Close reporting option for this user.
Open/Close Rep.? 0 = NO , 1 = YES	Press 0 (NO) or 1 (YES), depending on whether or not arming/disarming by this user will trigger Opening and Closing reports. This prompt appears only if the Installer Code is used to add a user.
Group Bypassing? 0 = NO , 1 = YES	Enter 1 (YES) to allow this user to perform group bypasses. Enter 0 (NO) this user will not be able to perform group bypasses. NOTE: In addition to enabling the user for group bypassing, the user must also have access to the partition(s) containing the zones being bypassed and have global arming capability.
Access Group? Enter 0-8	If access schedules have been programmed, this prompt appears. Enter the user's access group number (1-8) if this user should have limited access to the system. Enter 0 if no access group should be assigned.
RF Button ? 0=NO , 1=YES	If a 5800 Series button transmitter has been enabled for arming/disarming functions, and is not assigned to a user, this prompt appears. Press 0 (NO) or 1 (YES).
Enter Button ZN # (001-087)	If you answered "yes" to the RF button question, the zone number for the button is requested. Enter any one of the zone numbers assigned to the button transmitter as AWAY, STAY, or DISARM. The system then assigns all buttons of the transmitter to this user number.
Multi-Access ? 0 = NO , 1 = YES	Press 0 (NO) if the user is to have access to this partition only. Press 1 (YES) if the user is to have access to more than one partition. If NO, the program exits this mode. If YES, the keypad prompts for the Global Arm option for this user.
Global Arm ? 0 = NO , 1 = YES	Press 0 (NO) or 1 (YES), depending on whether this user will be allowed to arm more than one partition via Global Arm prompts (described in the <i>FA1700C User Guide</i>). The keypad now prompts for the user's access to the next partition.
Part. 2 – SHOP ? 0 = NO , 1 = YES	Press 0 (NO) or 1 (YES), depending on whether this user will have access to the displayed partition number. If NO, the keypad displays this prompt for the next partition number in sequence. If YES, the keypad prompts for the following: <ul style="list-style-type: none"> • User's authority level in the displayed partition (see Authority Level prompt above). • Open/Close option for this user in the displayed partition (see Open/Close prompt above). • Global Arm option for this user in the displayed partition. When all partitions have been displayed, the keypad will scroll through all partitions to which access has been assigned, and will display the user number, authority level, open/close and global arm options that were programmed for each partition to which the user was granted access. For example:

PROMPT	EXPLANATION
XMT USER DATA 1 = YES 0 = NO	If the user number is from 001-050 this appears. Answer YES (1) to have the system send the user's attributes to all the other control panels that are "linked" to this control. If you answer NO (0), the system displays the following prompt on the next page.
INDV USER PGM 1 = YES 0 = NO	Answer YES (1) to link to another control panel and manually enter the user into partition(s) in that control panel. If you answer NO (0), the system scrolls through each partition displaying a summary of the user's attributes in each partition (see next prompt).
Part. 1 A0* WHSE User 003 Auth=3G.	Note that the "G" following the authority level indicates that the global arm feature is enabled for this user in the displayed partition, and that the period at the end of the second line indicates Open/Close reporting is enabled for this user in the displayed partition. The "*" indicates the partition from which the user may be changed or deleted.

Changing a Master, Manager, or Operator Code

Enter **Installer Code** * + [8] + **new user no. (002-250) + new user's code**

*Or Master or Manager Code, but the code must be a higher level of authority than the code being changed (e.g. a Manager Code can add an Operator-level Code, but cannot add a Master or another Manager Code).

PROMPT	EXPLANATION
User Number = 003 NEW USER?	The system detects that the user number is already assigned, and prompts if this is a new user. Press 0 (NO). The system then confirms that the change is allowed based on authorization level.

Adding an RF Key to an Existing User

To add an RF key to an existing user, or to change a user's global arm option, first delete that user's code, then re-add the user code as described in the "Adding a Master, Manager, or Operator Code" paragraph.

Deleting a Master, Manager, or Operator Code

Enter **your code** * + [8] + **new user no. (002-250) + your code again**

*Or Master or Manager Code, but the code must be a higher level of authority than the code being changed (e.g. a Manager Code can add an Operator-level Code, but cannot add a Master or another Manager Code).

PROMPT	EXPLANATION
OK TO DELETE 003? 0=NO 1=YES	The system prompts to confirm that you want to delete this user. Press 0 (NO) or 1 (YES). If you answered "yes," that user's code is removed from all partitions to which it was assigned, and all authorization levels and other information about that user are deleted. Note that a user can be deleted only by a user with a higher authority level. A user cannot delete himself.



A user code can be deleted only from the partition through which it was entered. If an attempt is made to delete from another partition, the message "User [XXX] Not Deleted" is displayed.

Exiting the User Edit Mode

Press either [*] or [#], or don't press any key for 10 seconds.

Testing the System

Battery Test

When AC power is present, the FA1700C runs a brief battery test every 60 seconds to determine if there is a battery connected, and runs an extended battery test every 4 hours to check on the battery's condition.

If the FA1700C finds that the battery voltage is low (less than approximately 11.5V), it initiates a keypad "SYSTEM LOBAT" display and a rapid keypad beeping sound. It also sends a Low Battery report to the central station (if programmed). The keypad is cleared by entering any security code + OFF, and a Restore report is sent to the central station if the situation has been corrected.

Dialer Test

The FA1700C may be programmed to automatically transmit test reports to a central station at intervals ranging from once per hour to once per 9999 hours (field *27).

UL requires the test report to be transmitted at least once every 24 hours. The system can be programmed to send the first report at any time of the day, or on any day of the week (field *83).

Fire Drill Test (Code + [#] + 69)

This test causes fire Notification Appliance Circuits (or any NAC having a non-zero response type programmed) to be activated (in either steady or pulsing manner, as programmed in field 3*15, for the purpose of conducting a fire drill or bell test. This test can only be activated by the installer or master users from partition 1 keypads by entering the corresponding security code + [#] + 69. The burglary portion of the system must be disarmed.

Keypads display "FIRE DRILL ACTIVE" while the test is active. The test is stopped by entering any user code + OFF.

The system continues to monitor all 24-hour type zones (fire, panic, etc.) and ends the test if any of these zone types produce an alarm condition.

This test should be conducted at periodic intervals, as determined by the local authority having jurisdiction.

One-Man Fire Walk-Test (Code + [#] + 68)

This test causes the system to sound console beeps and Notification Appliance Circuit dings in response to fire zone faults (zone type 9, 16 & 17) for the purpose of allowing proper zone operation to be checked without triggering alarms. Note that the system will not be operational as an alarm system (i.e., cannot sense alarms) while this test is active. The test can only be activated by the installer by entering the Installer's Code and pressing [#] + 68 while the burglary portion of the system is disarmed.

This test should be conducted at periodic intervals, as determined by the local authority having jurisdiction.



When testing non-latching devices, such as heat detectors, be sure to keep the device faulted until the system responds with the keypad beep or siren sound. If the device is faulted only momentarily, the system may not respond to the fault.

When this test is first activated, the system will display:

PROMPT	EXPLANATION
USE BELL DING? 0=NO 1=YES	Enter 1 (YES) to have the fire Notification Appliance Circuits associated with each point sound for 3 seconds when a point is faulted. Enter 0 (NO) if only keypad sounders are desired. The next prompt will be displayed.

PROMPT	EXPLANATION
AUTO-TEST DET? 0=NO 1=YES	Enter 1 (YES) to have the system automatically test all polling loop points with a fire response type 9 or 16. Other fire zones will have to be tested manually. Enter 0 (NO) to test every point manually. The next prompt will be displayed.



For true detector sensitivity tests, and for compliance with fire codes, you must enter **0 (NO)** to this question.

LOG RESULTS? 0=NO 1=YES	Enter 1 (YES) to have the system log each point as it is tested. A list of untested points will also be logged. Enter 0 (NO) if you do not want to log the results. The next prompt will only be displayed if Contact ID report format has been selected.
C.S. TRANSMIT? 0=NO 1=YES	Enter 1 (YES) to have the results of the test sent to the central station. This report will consist of a list of points that have been tested followed by a list of points that have not been tested. Enter 0 (NO) if you do not want to report the results. A Walk-Test Start and Walk-Test End report will be sent in either case (if programmed).

When the Test Mode is activated, the system will sound fire Notification Appliance Circuits (or any NAC having a non-zero response type programmed in the #93 Menu Mode) for 3 seconds. The system will also send a Start of Walk-Test message to the central station, and will light all keypad indicators (except the ARMED LED) and display window segments to verify that they are working properly. The keypads will then display Fire Walk-Test in Progress and will sound a single beep every 15 seconds while this test is active.

The system will build a list of all the fire zones (response types 9, 16, 17, 18) that need to be tested. These points will be scrolled on the display. For each point, the keypad will display "UNTST XXX," where XXX is the point number, followed by an alpha descriptor for the point.

If the auto-test option has been selected, the control panel will attempt to automatically test all of the polling loop points that have a zone response type of 9 or 16. For points that must be manually tested, fault and reset each fire alarm sensor in turn.

Each action should cause keypads to beep and fire Notification Appliance Circuits to ding. The keypads will display the zone number and the associated alpha descriptor while the zone remains faulted. The system automatically issues a smoke detector power reset about 10 seconds after it finds a fault on one of these zones, to allow faulted detectors to be reset.



The system will automatically perform the smoke detector reset on zones 1 & 2, if programmed for fire, and on the auxiliary relay and any other output device (relay) that is programmed for smoke detector reset.

To end the test, enter any security code and press OFF. An End of Walk-Test message will be sent to the central station (if programmed). Note that the test will automatically end if no faults are detected within a 60-minute time period.

Burglary Walk-Test (Code + [5] TEST)

This test causes the system to sound keypad beeps in response to faults on zones for the purpose of allowing proper zone operation to be checked without triggering alarms. This test can be activated by any user by entering the corresponding security code and pressing TEST while the burglary portion of the system is disarmed. UL requires that this test be conducted on a weekly basis.

When this test is first entered, the system activates the alarm output for 3 seconds. The system sends a Start of Walk-Test message to the central station. The keypad displays "Burg Walk Test in Progress" and sounds a single beep every 15 seconds while the test remains active.

Open and close each protected door and window in turn. Each action should produce 3 beeps from the keypad. Walk in front of any motion detectors. Listen for three beeps when the detector senses movement. The keypad displays the zone number and alpha descriptor while a door or window remains open or while a detector remains activated. The system automatically issues a Zone 8 Glassbreak Detector Power Reset about 10 seconds after it finds a fault on this zone, to allow faulted detectors to be reset.

To end this test, enter any security code and press OFF. An End of Walk-Test message is sent to the central station.



The system automatically exits the Test mode if there is no activity (no doors or windows are opened and closed, no motion detectors are activated, etc.) for 60 minutes. The system beeps the keypad(s) twice every 5 seconds during the last 5 minutes as a warning that it is about to exit the Test mode and return to normal operation.

Armed Burglary System Test



- Alarm messages are sent to the central station during the armed tests. Notify the central station that a test will be in progress.
- A display of “COMM FAILURE” indicates a failure to communicate (no kiss-off by the receiver at the central station). If this occurs, verify that the phone line is connected, the correct report format is programmed, etc.

To perform an armed burglary test, proceed as follows:

Step	Action
1	Notify the central station that a test of the system is being performed.
2	Arm the system.
3	Fault one or more zones.
4	Silence alarm sounder(s) each time by entering the code and pressing OFF. NOTE: The system must be rearmed after each code + off sequence.
5	Check that entry/exit delay zones provide the assigned delay times.

Step	Action
6	Check the keypad-initiated alarms, if programmed, by pressing the panic key pairs (* and #, 1 and *, and/or 3 and #). The word ALARM and a descriptor “999” are displayed for * and #. If [1] and [*] are pressed, “995” is displayed; if [3] and [#] are pressed, “996” is displayed.
7	If the system has been programmed for audible emergency, the keypad emits a loud, steady alarm sound. Silence the alarm by entering the security code and pressing OFF. If the system has been programmed for silent panic, there are no audible alarms or displays. A report is sent to the central station, however.
8	Notify the central station that all tests are finished, and verify results with them.

Testing Wireless Transmitters

Transmitter ID Sniffer Mode

Use the Transmitter Sniffer Mode to test that transmitters have all been properly programmed.



If a transmitter does not have its serial number “enrolled,” it will not turn off its zone number.

To enter the Transmitter ID Sniffer Mode, proceed as follows:

Step	Action
1	Enter Installer Code + [#] + [3] . The keypad displays all zone numbers of wireless units programmed into the system.
2	Fault each wireless zone, causing each device to transmit. As the system receives a signal from each of the transmitters, the zone number of that transmitter disappears from the display.
3	Enter Installer Code + OFF to exit the Sniffer Mode.

Go/No Go Test Mode

This mode assists in determining good mounting locations, and that the RF transmission has sufficient signal amplitude margin for the installed system.



- All partitions with wireless transmitters must be placed in the test mode for RF receiver sensitivity reduction (50%). Otherwise, the RF receiver remains at full strength.
- Make sure that all partitions are disarmed for this test.

To enter the Go/No Go Test Mode, proceed as follows:

Step	Action
1	Enter Installer Code + [5] .
2	Fault each wireless transmitter, causing each device to transmit. The keypad will beep three times if the signal is received.
3	If the keypad does not beep, reorient or move the transmitter to another location. Usually a few inches in either direction is all that is required.
4	Enter Installer Code + OFF to exit the Go/No Go Test Mode.

Trouble Conditions

Supervisory Messages

Display	Description
SUPV + Zone Number	This indicates that a fire supervisory condition exists on the zone number displayed. This means that the operation of the fire alarm system may be compromised.

Check or Trouble Messages

Display	Description
CHECK or TRBL (as per field 1*07)	<p>This indicates that a problem exists on the zone number displayed. Zone trouble may be caused by one of the following conditions:</p> <ul style="list-style-type: none"> • A hardwired fire zone is open (broken wire). • A Day/Night zone (zone type 5) is faulted. • A polling loop zone is not seen by the control panel. • A polling loop zone has been tampered (cover removed on a 4190). • A wireless zone has not checked in during the time programmed in field 1*31. • A 5800 Series transmitter has been tampered (cover removed).
CHECK 6XX XX = 01-32	This indicates a trouble on a 4204CF Supervised Notification Appliance Circuit (corresponding relay number 01-32).
CHECK 8XX XX = 00-30	This indicates a trouble on a peripheral device (connected to the panel's keypad terminals) of the corresponding device address (00-30).
CHECK 9XX XX = 00-99	This indicates that a system trouble exists (RF receiver, Notification Appliance Circuit, etc.).



If the problem has been corrected, enter an OFF sequence (**Security Code + OFF**) twice to clear the display.

Power Failure

Display	Description
AC LOSS POWER LED is off	This indicates that the system is operating on battery power only. Check to see that the circuit breaker for the branch circuit that your system's transformer is wired to has not been accidentally turned off. Instruct the user to call a service representative immediately if AC power cannot be restored.

Other System Messages

Display	Description
COMM FAILURE	Indicates a failure occurred in the telephone communication portion of your system.
LO BAT	Indicates a low-battery condition exists in the wireless transmitter displayed. Pressing any key silences the audible warning sound.
SYSTEM LO BAT	This indicates that a low-battery condition exists with the system's backup battery.
HSENS	Indicates a smoke detector with a high sensitivity level, which may cause a false alarm. The detector should be cleaned or replaced.
LSENS	Indicates a smoke detector with a low sensitivity level. The detector may not detect a smoke condition. The detector should be cleaned or replaced.
RCVR SETUP ERROR	Indicates the system has more wireless zones programmed than the RF receiver can support. If this is not corrected, none of the zones in the system will be protected. If additional wireless zones are desired, use an appropriate receiver.
MODEM COMM	This indicates that the control is on-line with a remote computer.

System Off-Normal Report

If programmed, an Off-Normal report is generated instead of the periodic test report if any of the following conditions are present at the time of the report:

- Fire trouble on any zone (zone types 9, 16, 17, 18)
- Fire supervisory present (zone type 18)
- Unrestored fire alarm on any zone
- Bypass of any fire zone
- A fault for any supervised fire Notification Appliance Circuit
- Bypass/disable of any supervised fire Notification Appliance Circuit
- Telco fault of either dialer line
- Bypass/disable of either dialer line
- Earth ground fault
- Bypass of earth ground supervisory zone
- Fault on LORRA "XMIT OK" signal (if enabled)
- LORRA trigger bypassed
- AC failure
- Low system battery
- Keypad supervision fault

The Off-Normal report is sent as follows:

- Contact ID: Code 608
- High Speed: Channel 3 of system report used (channel 9=6)
- Low Speed: Digits programmed in System Group #4 report codes

To the Installer

Regular maintenance and inspection (at least annually) by the installer and frequent testing by the user are vital to continuous satisfactory operation of any alarm system.

The installer should assume the responsibility of developing and offering a regular maintenance program to the user as well as acquainting the user with the proper operation and limitations of the alarm system and its component parts. Recommendations must be included for a specific program of frequent testing (at least weekly) to ensure the system's proper operation at all times.

Turning the System over to the User

Fully explain the operation of the system to the user by going over each of its functions, as well as the User's Manual supplied.

In particular, explain the operation of each zone (entry/exit, perimeter, interior, fire, etc.). Be sure the user understands how to operate any emergency feature(s) programmed into the system.

Contacting Technical Support

PLEASE, before you call Technical Support, be sure you:

- READ THE INSTRUCTIONS!
- Check all wiring connections.
- Determine that the power supply and/or backup battery are supplying proper voltages.
- Verify your programming information where applicable.
- Verify that all keypads and devices are addressed properly.
- Note the proper model number of this product, and the version level (if known) along with any documentation that came with the product.
- Note your FIRST ALERT customer number and/or company name.

Having this information handy will make it easier for us to serve you quickly and effectively.

You may contact Technical Support via Toll-Free Fax. Please include your return fax number. You will receive a reply within 24 hours.

Technical Support: 1-800-645-7492 (8 a.m.-8 p.m. EST)
 ATLIS-FAX FAXBACK Automated Fax Retrieval System: 1-800-573-0153 or
 1-516-921-6704 / ext. 1667
 World Wide Web Address: [HTTP://WWW.ADEMCO.COM](http://WWW.ADEMCO.COM)

Regulatory Agency Statements

UL Installation Requirements

The following requirements apply to both UL residential and UL commercial burglary installations:

1. All partitions must be owned and managed by the same person(s).
2. All partitions must be part of one building at one street address.
3. The audible alarm device(s) must be placed where it/they can be heard by all partitions.
4. The control cabinet must be protected from unauthorized access. This can be done by installing a tamper switch on the cabinet door (supplied with FA1700C) or by installing a UL Listed passive infrared detector positioned to detect cabinet access. Wire the selected device to any EOLR-supervised zone (Zone 1-8). Program this zone for day trouble/night alarm (type 05) or 24-hour audible alarm (type 07) response. The 24-hour alarm response must be used for multiple partitioned systems.
5. Remote downloading and auto-disarming are not UL Listed features.

UL864/NFPA Local Fire

Configure at least one Notification Appliance Circuit for supervision and wire polarized fire alarm indicators to it. Program this circuit for temporal sounding.

UL864/NFPA Central Station and Remote Station Fire

1. Size the backup battery for 24-hour standby (central station) or 60-hour standby (remote station) time.
2. For central station service, you may use the 7720ULF or 7920SE LORRAs alone, the main dialer with a LORRA, or the main dialer with the 5140DLM Backup Dialer Module. For remote station service, you must use the main dialer with the 5140DLM Backup Dialer Module.
3. When using the LORRA, connect its channel inputs to the FA1700C's fire alarm, fire supervisory (if used), and trouble triggers. Also connect its XMIT OKAY output to Input 1 on the FA1700C's J2 header. Program J2 Input 1 system Zone 973 for 24-hour trouble response (type 19) to send radio faults.
4. When the main dialer is used, enable it (field 3*30) and connect it to a telephone line. Assign a 24-hour trouble response (type 19) to system Zone 974 to enable main dialer supervision. The FA1700C will activate the trouble trigger when it detects a main dialer supervision fault.
5. When the backup dialer is used, install it on the FA1700C's PCB shield. Enable it (field 3*30) and connect it to a separate telephone line. Assign a 24-hour trouble response (type 19) to system Zone 975 to enable backup dialer supervision.
6. When the dialer is used, program it to send fire alarm, fire supervisory (if used), trouble, AC loss, low battery, normal dialer test, and off-normal dialer test reports. Field *27 must be set to "024" maximum so that test reports are sent at least once every 24 hours.
7. If a secondary number is programmed, set the maximum number of dialer re-tries to 3, 4, or 5 in field 3*21.

UL609 Grade A Local Mercantile Premises/Local Mercantile Safe & Vault

1. Use the FA1700C.
2. All zones must be configured for EOLR supervision (*41=0). Wireless sensors may not be used. If 4190WH RPMs are used, set field *24 to "0" to enable tamper detection.
3. Attach a door tamper switch (supplied) to the FA1700C cabinet backbox. For safe and vault installations, a shock sensor (not supplied) must also be attached to the backbox. (Also see *Mounting the Cabinet* in *SECTION 3: Installing the Control*)
4. Wire an ADEMCO AB12 Grade A Bell/Box to the Notification Appliance Circuit. Bell wires must be run in conduit. Program the Notification Appliance Circuit for 16 minutes or longer timeout and for confirmation of arming ding. (Also see *SECTION 3: Installing the Control*)

5. Wire the FA1700C tamper switch and AB12 Bell/Box tamper switches to any EOLR supervised zone (zones 1-8). Program this zone for day trouble/night alarm (type 05) or 24-hour audible alarm (type 07) response. The 24-hour alarm response must be used for multiple partitioned systems.
6. Entry delays must not exceed 45 seconds, and exit delays must not exceed 60 seconds.

UL365 Police Station Connected Burglar Alarm

Follow the instructions for UL609 local installations given above.

For Grade A Service:

- You may use the FA1700C dialer alone, or the 7720 Long Range Radio alone.
- When using the dialer, program it to send Burglary Alarm, Low Battery and Communicator Test reports. Field *27 must be set to "024" (or less) so that test reports are sent at least once every 24 hours.
- If using the 7720, connect it to the FA1700C burglary/audible panic alarm trigger.

For Grade AA Service:

- You must use a 7920SE Long Range Radio.
- Connect the 7920SE to the FA1700C burglary/audible panic alarm trigger.

UL611/UL1610 Central Station Burglary Alarm

Follow the instructions for UL609 local installations given above.

For Grade A Service:

- You must use the FA1700C's dialer with a 7720 Long Range Radio.
- Connect the control's burglary/audible panic alarm trigger (on J2 header) to the 7720. Program a 24-hour trouble response for Zone 974 to enable main dialer supervision. The FA1700C will activate the burglary/audible panic trigger when a corresponding alarm is detected, and will activate the trouble trigger when a main dialer fault is detected.
- Also connect the 7720's radio fault output to one of the FA1700C's EOLR-supervised zones (i.e., 1-8). Program this zone for a trouble by day/alarm by night (type 05) or a 24-hour alarm (type 07, 08) response to radio faults.
- Program the control's dialer to send Burglary Alarm, Trouble, Opening/Closing, and Low Battery reports.

For Grade AA Service:

Follow the instructions for Grade A service, except use the 7920SE in place of the 7720.

California State Fire Marshal (CSFM) Requirements.

24-hour backup: The California State Fire Marshal has published new regulations which require that all residential fire alarm control panels installed after June 30, 1993 must be provided with a backup battery which has sufficient capacity to operate the panel and its attached peripheral devices for 24 hours in the intended standby condition, followed by at least 4 minutes in the intended fire alarm signaling condition. Be sure to size the battery to meet this requirement.

FEDERAL COMMUNICATIONS COMMISSION (FCC) PART 15 STATEMENT

NOTE: This equipment has been tested and found to comply with the limits for a Class B digital device, pursuant to part 15 of the FCC Rules. These limits are designed to provide reasonable protection against harmful interference in a residential installation. This equipment generates, uses, and can radiate radio frequency energy and, if not installed and used in accordance with the instructions, may cause harmful interference to radio communications. However, there is no guarantee that interference will not occur in a particular installation. If this equipment does cause harmful interference to radio or television reception, which can be determined by turning the equipment off and on, the user is encouraged to try to correct the interference by one or more of the following measures:

- Reorient or relocate the receiving antenna.
- Increase the separation between the equipment and receiver.
- Connect the equipment into an outlet on a circuit different from that to which the receiver is connected.
- Consult the dealer or an experienced radio/TV technician for help.

IN THE EVENT OF TELEPHONE OPERATIONAL PROBLEMS

In the event of telephone operational problems, disconnect the control panel by removing the plug from the RJ31X (CA38A in Canada) wall jack. We recommend that you demonstrate disconnecting the phones on installation of the system. Do not disconnect the phone connection inside the control panel. Doing so will result in the loss of your phone lines. If the regular phone works correctly after the control panel has been disconnected from the phone lines, the control panel has a problem and should be returned for repair. If upon disconnection of the control panel, there is still a problem on the line, notify the telephone company that it has a problem and request prompt repair service. The user may not under any circumstances (in or out of warranty) attempt any service or repairs to the system. It must be returned to the factory or an authorized service agency for all repairs.

FCC PART 68 NOTICE

This equipment complies with Part 68 of the FCC rules. On the front cover of this equipment is a label that contains, among other information, the FCC registration number and ringer equivalence number (REN) for this equipment. If requested, this information must be provided to the telephone company.

This equipment uses the following jacks:

An RJ31X is used to connect this equipment to the telephone network.

The REN is used to determine the quantity of devices that may be connected to the telephone line. Excessive RENs on the telephone line may result in the devices not ringing in response to an incoming call. In most, but not all areas, the sum of the RENs should not exceed five (5.0). To be certain of the number of devices that may be connected to the line, as determined by the total RENs, contact the telephone company to determine the maximum REN for the calling area.

If this equipment causes harm to the telephone network, the telephone company will notify you in advance that temporary discontinuance of service may be required. If advance notice is not practical, the telephone company will notify the customer as soon as possible. Also, you will be advised of your right to file a complaint with the FCC if you believe necessary.

The telephone company may make changes in its facilities, equipment, operations, or procedures that could affect the operation of the equipment. If this happens, the telephone company will provide advance notice in order for you to make the necessary modifications in order to maintain uninterrupted service.

If trouble is experienced with this equipment, please contact the manufacturer for repair and warranty information. If the trouble is causing harm to the telephone network, the telephone company may request that you remove the equipment from the network until the problem is resolved.

There are no user serviceable components in this product, and all necessary repairs must be made by the manufacturer. Other repair methods may invalidate the FCC registration on this product.

This equipment cannot be used on telephone company-provided coin service. Connection to Party Line Service is subject to state tariffs.

This equipment is hearing-aid compatible.

When programming or making test calls to an emergency number, briefly explain to the dispatcher the reason for the call. Perform such activities in the off-peak hours, such as early morning or late evening.

CANADIAN EMISSIONS STATEMENTS

This Class B digital apparatus complies with Canadian ICES-003

NOTICE

The Industry Canada Label identifies certified equipment. This certification means that the equipment meets telecommunications network protective, operational and safety requirements as prescribed in the appropriate Terminal Equipment Technical Requirements document(s). The Department does not guarantee the equipment will operate to the user's satisfaction.

Before installing this equipment, users should ensure that it is permissible to be connected to the facilities of the local telecommunications company. The equipment must also be installed using an acceptable method of connection. The customer should be aware that compliance with the above conditions may not prevent degradation of service in some situations.

Repairs to certified equipment should be coordinated by a representative designated by the supplier. Any repairs or alterations made by the user to this equipment, or equipment malfunctions, may cause the telecommunications company to request the user to disconnect the equipment.

Users should ensure for their own protection that the electrical ground connections of the power utility, telephone lines, and internal metallic water pipe system, if present, are connected together. This precaution may be particularly important in rural areas.

Caution: Users should not attempt to make such connections themselves, but should contact an appropriate electric inspection authority, or electrician, as appropriate.

NOTICE: The **Ringer Equivalence Number** (REN) assigned to each terminal device provides an indication of the maximum number of terminals allowed to be connected to a telephone interface. The termination on an interface may consist of any combination of devices subject only to the requirement that the sum of the Ringer Equivalence Numbers of all the devices does not exceed 5.

AVIS

L'étiquette d'Industrie Canada identifie le matériel homologué. Cette étiquette certifie que le matériel est conforme aux normes de protection, d'exploitation et de sécurité des réseaux de télécommunications, comme le prescrivent les documents concernant les exigences techniques relatives au matériel terminal. Le Ministère n'assure toutefois pas que le matériel fonctionnera à la satisfaction de l'utilisateur. Avant d'installer ce matériel, l'utilisateur doit s'assurer qu'il est permis de le raccorder aux installations de l'entreprise locale de télécommunication. Le matériel doit également être installé en suivant une méthode acceptée de raccordement. L'abonné ne doit pas oublier qu'il est possible que la conformité aux conditions énoncées ci-dessus n'empêche pas la dégradation du service dans certaines situations.

Les réparations de matériel homologué doivent être coordonnées par un représentant désigné par le fournisseur. L'entreprise de télécommunications peut demander à l'utilisateur de débrancher un appareil à la suite de réparations ou de modifications effectuées par l'utilisateur ou à cause de mauvais fonctionnement.

Pour sa propre protection, l'utilisateur doit s'assurer que tous les fils de mise à la terre de la source d'énergie électrique, de lignes téléphoniques et des canalisations d'eau métalliques, s'il y en a, sont raccordés ensemble. Cette précaution est particulièrement importante dans les régions rurales.

Avertissement : L'utilisateur ne doit pas tenter de faire ces raccordements lui-même; il doit avoir recours à un service d'inspection des installations électriques, ou à un électricien, selon le cas.

AVIS : L'indice d'équivalence de la sonnerie (IES) assigné à chaque dispositif terminal indique le nombre maximal de terminaux qui peuvent être raccordés à une interface. La terminaison d'une interface téléphonique peut consister en une combinaison de quelques dispositifs, à la seule condition que la somme d'indices d'équivalence de la sonnerie de tous les dispositifs n'excède pas 5.

Summary of System Commands

User Code Commands	<p>Add A User Code = User Code + 8 + New User Number + New User's Code Change a Code = User Code + 8 + User Number + New User's Code Delete a User's Code = Your User Code + 8 + User Number to Be Deleted + Your Code Again View User Capability = User's Code + [*] + [*] Set Real-Time Clock (Installer, Master Only) = Code + [#] + 63</p>												
Programming Commands	<p>Site Initiated Download = User Code + [#] + 1. Direct-Wire Download Enable = User Code + [#] + 5. Enter Program Mode = Installer Code + 8000. Enter Interactive Program Mode = Installer Code + 8000 + [#] + 93 Exit Program Mode = *99 or *98.</p>												
Event Logging Commands	<p>Event Log Display = Code + [#] + 60 (Installer or Master Only) Event Log Print = Code + [#] + 61 (Installer or Master Only) Clear Event Log = Code + [#] + 62 (Installer or Master Only)</p>												
Wireless System Commands	<p>House ID Sniffer Mode = Code + [#] + 2 (Installer Only) Transmitter ID Test = Code + [#] + 3 (Installer Only) Go/No Go Test = Code + 5 (Test Key)</p>												
Additional Commands	<table border="1"> <tr> <td data-bbox="410 1054 808 1094">Partition GOTO</td> <td data-bbox="808 1054 1464 1094">User Code + [*] + Partition Number 0-8.</td> </tr> <tr> <td data-bbox="410 1098 808 1138">GOTO Home Partition</td> <td data-bbox="808 1098 1464 1138">User Code + [*] + 0.</td> </tr> <tr> <td data-bbox="410 1142 808 1262">Panics</td> <td data-bbox="808 1142 1464 1262"> [*] + 1 or A Key (Zone 995). [*] + [#] or B Key (Zone 999). [#] + 3 or C Key (Zone 996). </td> </tr> <tr> <td data-bbox="410 1266 808 1306">View Downloaded Messages</td> <td data-bbox="808 1266 1464 1306">Press 0 for 5 Seconds.</td> </tr> <tr> <td data-bbox="410 1310 808 1350">Display All Zone Descriptors</td> <td data-bbox="808 1310 1464 1350">Press [*] for 5 Seconds.</td> </tr> <tr> <td data-bbox="410 1354 808 1388">Display User Self Help</td> <td data-bbox="808 1354 1464 1388">Hold Any Key for 5 Seconds.</td> </tr> </table>	Partition GOTO	User Code + [*] + Partition Number 0-8.	GOTO Home Partition	User Code + [*] + 0.	Panics	[*] + 1 or A Key (Zone 995). [*] + [#] or B Key (Zone 999). [#] + 3 or C Key (Zone 996).	View Downloaded Messages	Press 0 for 5 Seconds.	Display All Zone Descriptors	Press [*] for 5 Seconds.	Display User Self Help	Hold Any Key for 5 Seconds.
Partition GOTO	User Code + [*] + Partition Number 0-8.												
GOTO Home Partition	User Code + [*] + 0.												
Panics	[*] + 1 or A Key (Zone 995). [*] + [#] or B Key (Zone 999). [#] + 3 or C Key (Zone 996).												
View Downloaded Messages	Press 0 for 5 Seconds.												
Display All Zone Descriptors	Press [*] for 5 Seconds.												
Display User Self Help	Hold Any Key for 5 Seconds.												
Output Device Control Commands	<p>Activate Output Device as Programmed = User Code + [#] + 71. Activate Output Device as Programmed = User Code + [#] + 72. Activate Output Device Manually = User Code + [#] + 70. Activate Output Device or System Event Instantly = User Code + [#] + 77. Randomize Output Devices = User Code + [#] + 41 Randomize Output Devices Programmed with Activation Times Between 6 PM and 5 AM = User Code + [#] + 42. De-activate Randomization = Enter the sequence used to activate randomization.</p>												
Test Mode Commands	<p>Burglary Walk-Test = User Code + 5. Fire Drill Test = User Code + [#] + 69 (Installer or Master Only). One-Man Fire Walk-Test = User Code + [#] + 68 (Installer Only)</p>												

<p>Scheduling Commands</p>	<p>Installer-Programmed Schedule Events = Installer Code + [#] + 80 (Installer or Master Only). Temporary Schedule Editing = User Code + [#] + 81 (Installer, Master, Manager Only). Extend Closing Window = User Code + [#] + 82 (Installer, Master, Manager Only). End User Output Device Programming = User Code + [#] + 83.</p>
<p>Access Control Commands</p>	<p>Activate Access Relay for Current Partition = User Code + 0. Request to Enter/Exit = User Code + [#] + 73. Request to Enter/Exit at Access Point = User Code + [#] + 74 + Access Point Number. Change Access Point State = User Code + [#] + 75 + Access Point + State. Perform a Test of the VistaKey Module = Installer Code + [#] + 78. Perform an Access Control Card Function = User Code + [#] + 79.</p>
<p>Panel Linking Commands</p>	<p>Only user 001 – 050 can perform panel linking. Activate Single-Partition, Single-Panel Mode = User Code + [#] + 86. Exit Single-Partition, Single-Panel Mode = User Code + [#] + 85. Activate Multi-Partition, Multi-Panel Mode = User Code + [#] + 87. Exit Multi-Partition, Multi-Panel Mode = Enter [0]. Activate Multi-Panel View Mode = User Code + [#] + 88. Exit Multi-Panel View Mode = Enter [0].</p>

Specifications

FA1700C CONTROL

Physical:	18"H X 14-1/2"W X 4.3"D
Electrical:	
Primary Power:	From ADEMCO No. 1451 Transformer with enclosure; rated 18VAC, 72VA.
Backup Battery:	12VDC, 12AH min to 34.4AH max lead acid battery (gel type).
Alarm Power:	12VDC, 1.7 amps max for each Notification Appliance Circuit.
Aux. Standby Pwr	12VDC, 1 amp max.
Total Power	Combined auxiliary standby and alarm currents must not exceed 2.3 amps.
Standby Time:	24 hours with 1 amp aux standby load or 60 hours with 205ma aux. Standby load using 34.4AH battery.
Fusing:	Battery input, auxiliary and Notification Appliance Circuits are protected using PTC circuit protectors. All outputs are power limited.

Main Dialer

Line Seize:	Double Pole
Ringer Equivalence:	0.7B
FCC Registration No.:	AC3-USA-68192-AL-E
TLM Threshold	Good line when tip-to-ring voltage greater than approximately 25V (13 when blue jumper cut) or when handset current greater than approximately 10ma. Bad line when both voltage and current below these levels.
Formats:	ADEMCO High Speed, ADEMCO 4 + 2 Express, ADEMCO Low Speed, ADEMCO Contact ID, SESCOA and Radionics Low Speed

Agency Listings:

Burglary:	UL609 Grade A Local Mercantile Premises and Mercantile Safe and Vault. UL611/UL1610 Grades A, AA Central Station. UL365 Grades A, AA Police Connect.
Fire:	UL864-NFPA 72 Local, Central Station, and Remote Station

5140DLM BACKUP DIALER MODULE

Physical:	2.75"H X 4"W X 1"D Mounts on VISTA-128FB main PC board shield using standoffs supplied. Connects to VISTA-128FB main PC board J3 header using ribbon cable supplied.
FCC Registration:	AC3-USA-62628-MO-N

5140LED ANNUNCIATOR MODULE

Physical:	4.5"H X 2.75"W X 1.5"D Mounts to single-gang electrical box.
Indicators:	AC Power, Comm Failure, Dialer 1 Fault and Dialer 2 Fault. Connect indicator inputs to VISTA-128FB trigger outputs (J2 header).

Remote Keypads

FA560KP

Physical:

Width: 5-3/8 inches
Height: 7-5/16 inches
Depth: 1-3/8 inches

Electrical:

Voltage Input: 12VDC
Current Drain: 130mA

Interface Wiring:

RED: 12VDC input (+) auxiliary power
BLUE: Not Used
GREEN: Data to control panel
YELLOW: Data from control panel
BLACK: Ground and (-) connection from supplemental power supply

Contact ID and Pager Event Codes

TABLE OF CONTACT ID EVENT CODES

Code	Definition
110	Fire Alarm
111	Smoke Alarm
121	Duress
122	Silent Panic
123	Audible Panic
124	Duress Access Grant
125	Duress Egress Grant
131	Perimeter Burglary
132	Interior Burglary
133	24-Hour Burglary
134	Entry/Exit Burglary
135	Day/Night Burglary
140	ACS Zone Alarm
142	Polling Loop Short Alarm
150	24-Hour Auxiliary
200	Fire Supervisory
301	AC Loss
302	Low System Battery
305	System Reset
306	Program Tamper
308	System Shutdown
309	Battery Test Fail
310	Ground Fault
313	System Engineer Reset
320	ACS Relay Supervision
321	Bell 1 Trouble
322	Bell 2 Trouble
332	Poll Loop Short-Trouble
333	Expansion Module Failure
338	ACS Module Low Battery
339	ACS Module Reset
342	ACS Module AC Loss
343	ACS Module Self-Test Fail
351	Main Dialer Trouble
352	Backup Dialer Trouble
354	ACS RS232 Fail
373	Fire Loop Trouble
378	Cross Zone Trouble
380	Trouble (global)
381	Loss of Supervision (RF)
382	Loss of RPM Supervision
383	RPM Sensor Tamper
384	RF Transmitter Low Battery

Code	Definition
385	High Sensitivity Maintenance Signal
386	Low Sensitivity Maintenance Signal
389	Detector Self-Test Failed
401	O/C by User
403	Power-Up Armed/Auto-Arm
406	Cancel by User
407	Remote Arm/Disarm (Download)
408	Quick Arm
409	Keyswitch O/C
411	Callback Requested
421	Access Denied
422	Access Granted
423	Door Force Open
424	Egress Denied
425	Egress Granted
426	Door Prop Open
427	Access Point DSM Trouble
428	Access Point RTE Trouble
429	ACS Program Entry
430	ACS Program Exit
431	ACS Threat Change
432	Access Point Relay/Trigger Fail
433	Access Point RTE Shunt
434	Access Point DSM Shunt/Unshunt
441	Armed STAY
451	Early Open/Close
452	Late Open/Close
453	Fail to Open
454	Fail to Close
455	Auto-Arm Fail
457	Exit Error by User
459	Recent Close
501	ACS Reader Disable
520	ACS Relay Disable
521	Bell 1 Bypass
522	Bell 2 Bypass
524	Auxiliary Relay Bypass
551	Main/Backup Dialer Bypass
570	Bypass
576	ACS Zone Shunt
577	ACS Point Bypass
579	Vent Zone Bypass
602	Communicator Test

Code	Definition
604	Fire Test
606	Listen-In to Follow
607	Burglary Walk-Test
608	Off-Normal
611	Fire Walk-Test – Point Tested
612	Fire Walk-Test – Point Not Tested
621	Event Log Reset

Code	Definition
622	Event Log 50% Full
623	Event Log 90% Full
624	Event Log Overflow
625	Time/Date Reset
631	Exception Schedule Change
632	Access Schedule Change

Event Log and Pager Alpha Descriptors

Alpha	Event Description
FIRE	Fire Alarm
DURESS	Duress Alarm
PANIC	Silent or Audible Panic Alarm
BURGLARY	Burglary Alarm
EXP SHRT	Polling Loop Short
RF EXPND	Expander Module Failure
AUXILIARY	Non-burglary Alarm
TROUBLE	Trouble
AC LOSS	AC Loss
LOW BATTERY	System Low Battery
SYSTEM RESET	System Reset
PROG CHANGE	Program Change
BATTERY FAIL	System Battery Failure
RF SUPR	RF Supervision
RPM SUPR	RPM Supervision
RF LBAT	RF Low Battery
EXP TRBL	Expander Module Trouble
RF TRBL	RF Trouble
TAMPER	Tamper
FIRE TRB	Fire Trouble
FAIL TO COMM	Failure to Communicate
BELL TROUBLE	Bell Trouble
DISARMED	Disarmed
DISARMED-REM	Disarmed Remotely
DISARMED-KEY	Disarmed Via RF Key
DISARM-AUTO	Auto-Disarm
CALL BACK	Callback Requested
CANCEL	Cancel
DISRMD-EARLY	Disarmed Early
DISRMD-LATE	Disarmed Late
MISSED DISRM	Missed Disarm
SKED CHANGE	Schedule Change
ACC SKED CHG	Access Control Schedule Change
ARM FAILED	Failed to Arm
DIALER SHUT	Dialer Shutdown
SYSTEM SHUT	System Shutdown

Alpha	Event Description
BYPASS	Bypass
SELF TEST	Self-test
TEST ENTRY	Manual Test Entry
TEST EXIT	Manual Test Exit
LOG 50% FULL	Event Log 50% Full
LOG 90% FULL	Event Log 90% Full
LOG OVERFLOW	Event Log Overflow
LOG CLEARED	Event Log Cleared
TIME SET	Time Set
TIME ERROR	Time Error
PROGRM ENTRY	Program Entry
PROGRAM EXIT	Program Exit
Uxxx ADD BY	User XXX Added BY
Uxxx DEL BY	User XXX Deleted BY
Uxxx CHG BY	User XXX Changed BY
PRINTER FAIL	Event Log Printer Failure
PAGER FAILED	Pager Failure
TESTED	Zone Tested
UNTESTED	Zone Untested
FAILED	Zone Test Failed
RLY TRBL	Relay Trouble
EXP TMPR	Expansion Module Tamper
VENT BYPASS	Vent Zone Bypass
RF JAM	RF Jam Detected
JAM RSTR	RF Jam Restore
FIRE RST	Fire Alarm Restore
DURE RST	Duress Alarm Restore
PNC RST	Panic Alarm Restore
BURG RST	Burglary Alarm Restore
EXP RST	Expansion Module Restore
RF RST	RF Restore
AUX RST	Auxiliary Restore
MED RST	Medical Restore
TRBL RST	Trouble Restore
AC RESTORE	AC Restore
LOW BATT RST	System Low Battery Restore

Alpha	Event Description
RESET	
PROG CHANGE	Program Change
BAT TST FAIL	Battery Test Failure
RPM RST	RPM Restore
RFLB RST	RF Low Battery Restore
EXP RST	Expansion Module Failure Restore
TMPR RST	Tamper Restore
FRTR RST	Fire Trouble Restore
COMM RESTORE	Communication Restore
RLY RST	ECP Relay Trouble Restore
ARMED	Armed
ARMED-STAY	Armed Stay
ARMED-REM	Armed Remotely
ARMED-QUICK	Quick Armed
ARMED-KEY	Armed Via RF Key
ARMED-AUTO	Auto-Armed
PARTIAL ARM	Partial Armed
ARMED-EARLY	Armed Early
ARMED-LATE	Armed Late
MISSED ARM	Missed Arm
DIALER RST	Dialer Restore (Shutdown)
SYSTEM RST	System Restore (Shutdown)
BYP RST	Bypass Restore
TEST EXIT	Test Mode Exit
PRINTER RSTR	Printer Restore
PAGER RSTR	Pager Restore
BELL RESTORE	Bell Restore
EXIT ERR	Exit Error
RECENT ARM	Recent Arm
VENT BYP RST	Vent Zone Bypass Restore
Access Control Events	
ACS MOD	VGM/Access Control Module Failure
ACS PNT	Access Point Failure
DSM SHNT	Door Status Monitor Shunt
DUR ACCS	Duress Access Grant
NO ENTRY	Access Denied
DR OPEN	Door Propped Open
DR FORCE	Door Forced Open
ENTERED	Access Granted
NO EXIT	Egress Denied
ACPT BYP	Access Point Bypass
RTE SHNT	Request to Exit Shunt

Alpha	Event Description
EXITED	Egress Granted
ACLO MOD	AC Loss at Module
LBAT MOD	Low Battery at Module
COMM MOD	Comm Failure from MLB to Module
RES MOD	Access Control Module Reset
ACPT RLY	Access Point Relay Supervision Fail
SELF MOD	Module Self-Test Failure
ACZN CHG	Access Control Zone Change
ACS PROG	Access Control Program Entry
ACS PRGX	Access Control Program Exit
THRT CHG	Access Control Threat Change
SYS SHUT	System Shutdown
SYS RST	System Engineer Reset
ZN SHUNT	Access Control Zone Shunt
ZN ALARM	Access Control Zone Alarm
RDR DISA	Access Control Reader Disable
RLY DISA	Access Control Relay/Trigger Disable
RTE TRBL	Request to Exit Point Trouble
DSM TRBL	Door Status Monitor Point Trouble
DUR EXIT	Duress Egress Grant
BGN ACS TEST	Access Control Test Mode Start
MOD RST	VGM/Access Control Module Restore
ACPT RST	Access Point Restore
ACRST MOD	AC Loss at Module Restore
LBAT RST	Low Battery at Module Restore
COMM RST	Comm Fail MLB to Module Restore
RLY RST	Access Point Relay Supervision Rest
SELF RST	Self-Test at Module Restore
ACPT UNB	Access Point Unbypass
DSM UNSH	Door Status Monitor Unshunt
RTE UNSH	Request to Exit Point Unshunt
DRFO RST	Door Forced Open Restore
DRPO RST	Door Propped Open Restore
DSM RST	Door Status Monitor Trouble Restore
RTE RST	Request to Exit Point Trouble Rest
RLY ENAB	Access Control Relay/Trigger Enable
RDR ENAB	Access Control Reader Enable
ZNAL RST	Access Control Zone Restore
ZN UNSHT	Access Control Zone Unshunt
SYSHTRST	System Shutdown Restore
END ACS TEST	Access Control Test Mode End

Index

#93 Menu Mode Programming	4-2
#93 Menu Mode Programming Commands	4-4
12/24 Hour Type Stamp Format	5-11
1361	3-30
1451 Transformer	C-1
24-hour Audible Alarm Type 07	4-6
24-hour Auxiliary Alarm Type 08	4-6
24-hour Silent Alarm Type 06	4-6
2-Wire Latching Glassbreak Detectors	3-10, 3-11
2-Wire Smoke Detectors	3-8
333 PRM	3-9
4100SM Serial Module	7-4
4101SN Relay Modules	3-18
4197 Polling Loop Extender	3-13
4204 and 4204CF Relay Modules	3-17
4285/4286 VIP Module	3-27
4297 Polling Loop Extender	3-13
4-Wire Smoke Detector Reset	3-6
4-Wire Smoke Detectors	3-8
5140DLM BACKUP DIALER MODULE	C-1
5140LED ANNUNCIATOR MODULE	C-1
5800 Series Transmitters	3-16
5800TM Module	3-16
5869	1-2, 3-14
5881ENHC	1-2, 3-14
7720	3-23
7720ULF	3-23
7920SE	3-23

A

AAV	3-27
ABB1031	3-4
AC 60Hz or 50Hz	5-10
AC Loss Keypad Sounding	5-2
Access Group	9-3
Access Control	3-25, 3-26, 4-9
Access Control Commands	6-8, B-2
Access Control Dialer Enables	5-9
Access Control of an Entry/Exit Point	4-9
Access Control of Lighting and Appliances	4-10
Access Control Using RF Transmitter	4-9
ACCESS GRP PGM	4-3
ACCESS POINT PGM	4-3
Access Point Type 27	4-7
Access Relay Number	5-11
Access Schedules	6-5
Action Code	6-8
Action Specifier	6-8
Activation Time	6-8
Adding a User Code	9-3
Adding an RF Key to a User Code	9-4
Addressing the Keypads	3-3
ADEMCO 4+2 Express	3-7
ADEMCO 4+2 EXPRESS	C-1
ADEMCO 4146	3-19
ADEMCO 685 receiver	3-7
ADEMCO 685 Receiver	3-27
Ademco AB12	3-1
ADEMCO Contact ID	3-6, 3-7

ADEMCO CONTACT ID	C-1
ADEMCO HIGH SPEED	C-1
ADEMCO Low Speed	3-7
ADEMCO LOW SPEED	C-1
Affects Lobby	2-2, 5-7
Agency Listings	C-1
Agency Statements	A-1
Alarm Activation	3-5
Alarm Output Current Load	3-32, 3-33
Alarm Output Supervision	3-4
Alarm Power	C-1
Allow Disarm Outside Window if Alarm Occurs	5-12
Allow Disarming Only During Arm/Disarm Windows ..	5-12
Alpha Pager Module	3-23, 4-8
ALPHA PROG	4-3
Antenna Fault	3-22
Arm/Disarm Commands	6-8
Arm-Away Type 21	4-7
Arms Lobby	2-2, 5-7
Arm-STAY Type 20	4-7
Audio Alarm Verification Module	3-27
Auto Arming	6-1
Auto Disarming	6-1
Auto-Arm Delay	5-12, 6-1
Auto-Arm Warning	6-1
Auto-Arm Warning Period	5-12
Auto-Disarm Delay	5-12
Aux. Standby Pwr	C-1
Auxiliary Power Current Load	3-32
Auxiliary Relay Connections	3-5

B

Backup Battery	C-1
Battery Capacity Worksheet	3-34
Battery Selection Table	3-34
Battery Test	10-1
Burglary Alarm Communicator Delay	5-7
Burglary or RS232 Input	5-2
Burglary Trigger for Response Type 8	5-3
Burglary Walk Test	10-2
Button RF	3-16
Button RF (BR) Type 05	4-8
Bypass Commands	6-8

C

California State Fire Marshal	A-2
Call Waiting Defeat	5-10
Callback	7-3
Callback Requested	7-1
CANADIAN EMISSIONS STATEMENTS	A-4
Cancel Verify	5-7
Changing a User Code	9-4
Check Messages	10-4
Checksum Verification	5-5
Code + TEST [5]	10-1, 10-2
COMM FAILURE	10-4
Common Lobby	2-1

Communication Defaults 4-5
 Communicator Split Reporting Selection 5-9
 Compass Downloading Software 7-4
 COMPASS downloading software 7-1
 Compatible 2-Wire Smoke Detectors 3-8
 Compatible 4-Wire Smoke Detectors 3-8, 3-9
 Compatible 5800 Series Transmitters 3-17
 Compatible Alarm Indicating Devices 3-4
 Compatible Glass Break Detectors 3-11
 Confirmation of Arming Ding 5-2
 Console Input (CS) Type 09 4-8
 Contact ID 1-3
 CONTACT ID EVENT CODES D-1
 Contacting Technical Support 10-5
 Control Unit Power Supply Load 3-31
 Conventions Used in This Manual vii
 Cross Zoning Pair Four 5-8
 Cross Zoning Pair One 5-8
 Cross Zoning Pair Three 5-8
 Cross Zoning Pair Two 5-8
 Cross-Zoning 5-8
 CUSTOM INDEX 4-3

Enable Dialer Reports for Panics & Duress 5-6
 Enable GOTO for this Partition 5-12
 Enable J7 Triggers for Partition 5-13
 Enable Open/Close Report for Installer Code 5-4
 Enable Open/Close report for Keyswitch 5-4
 Enable Random Timers For Partitions 1-8 5-1
 Entering Programming Mode 4-1
 Entry Delay #1 5-2
 Entry Delay #2 5-2
 Entry Warning 5-6
 Entry/Exit #1 Type 01 4-6
 Entry/Exit #2 Type 02 4-6
 Event Log 3-27, 4-10
 Event Log and Pager Alpha Descriptors D-2
 Event Log Printer On-Line Mode 5-11
 Event Log Types 5-11
 Event Logging Commands B-1
 EVENT/ACTION PGM 4-3, 4-4
 Exception Reports 6-2
 Exit Delay #1 5-2
 Exit Delay #2 5-2
 Exit Delay Sounding 5-10
 Exit Error 1-2
 Exit Error Logic Enable 5-7
 Exiting the User Edit Mode 9-5
 EXPERT MODE 4-3
 Extend Closing Window 6-1
 External Sounders 3-4

D

Data Encryption 7-1
 Data Field Descriptions 5-1
 Data Field Programming Mode 4-1
 Daylight Saving Time Start/End Month 5-11
 Daylight Saving Time Start/End Weekend 5-12, 5-17
 Deleting a User Code 9-5
 DEVICE PROG 4-3
 Dial Tone Detection 5-4
 Dial Tone Pause 5-4
 Dialer Test 10-1
 DIGITAL COMMUNICATOR C-1
 DIP Switch Loop (DP) Type 07 4-8
 Direct-Wire Downloading 7-4
 Disable Download Callback 5-10
 Disarm Delay 6-1
 Disarm Type 22 4-7
 Display Burglary & Panic Alarms for Other Partitions .. 5-13
 Display Fire Alarms of Other Partitions 5-13
 Display Troubles of Other Partitions 5-13
 Door Status Monitor (DSM) Type 11 4-8
 Download Command Enables 5-4
 Download ID Number 5-4
 Download Phone Number 5-4
 Downloading 7-1
 Downloading Access Security 7-1
 Downloading Requirements 7-1
 Dual Reporting 5-5
 Duress Codes Level 6 9-2
 Duress Reporting 9-2
 Dynamic Signaling Delay 3-21, 5-6
 Dynamic Signaling Priority 3-21, 5-6

E

Early Power Detect 3-22
 Earth Ground 3-31
 ECP Wire Run 3-20
 Enable 5800 RF Button Force Arm 5-11
 Enable 5800 RF Button Global Arm 5-11

F

FA560KP C-2
 FCC Part 15 STATEMENT A-3
 FCC PART 68 NOTICE A-3
 FCC REGISTRATION NO. C-1
 Fire With Verification Type 16 4-7
 First Communication 7-3
 First Test Report Time 5-6
 Force Arm 6-1
 Force Arm Enable for Auto-Arm 5-12
 Frwd. Power Loss 3-22
 FSA Modules 3-18
 Fusing C-1

G

General Description 1-1
 General Purpose (GP) Type 13 4-8
 Getting On-Line with a Control Panel 7-2
 Global Arm ? 9-3
 Go/No Go Test Mode 10-1
 Grade A Mercantile Premises Listing 3-1
 Grade A Mercantile Safe and Vault Listing 3-2
 Grade A Service A-2
 Grade AA Service A-2

H

Hardwire and Optional Expansion Zones 1-1
 Hardwired (HW) Type 01 4-7
 Holiday Schedule Programming 6-7
 Holiday Schedules 6-3, 6-4, 6-6
 House ID Sniffer Mode 3-16
 How to Use Panel Linking B-2

I

Ignore Expansion Zone Tamper	5-3
Installer (User 1) Code Level 0	9-1
Installer Code	5-1
Installer Unattended Program Mode	7-2
Installing RPM Devices	3-12
Installing The Control	3-1
Installing the Control's Circuit Board	3-2
Intelligent Test Report	5-3
Interior w/Delay Type 10	4-7
Interior, Follower Type 04	4-6

K

Keypad Panic Enables	5-3
Keypads	2-1
Keyswitch	3-19
Keyswitch Assignment	5-2
Keyswitch Tamper	3-19

L

Limitation of Access Schedules	6-2, 6-11
Limitation Of Access Schedules Programming	6-11
LINE SEIZE	C-1
List of Figures	vi
LO BAT	10-4
Lobby Partition	5-7
Long Range Radio Central Station #1 Category Enable	5-6
Long Range Radio Central Station #2 Category Enable	5-6
Long Range Radio ECP	3-21, 4-10
Long Range Radio to J7 Triggers	3-23
Low Speed Format (Primary)	5-5
Low Speed Format (Secondary)	5-5
LRR Battery	3-22
LRR CRC is bad	3-22
LRR reporting options	3-22
LRR Trouble Messages	3-22

M

Main Logic Board	3-26
Main Logic Board Supervision Type 28	4-7
Manager Codes Level 2	9-1
Master Codes Level 1	9-1
Master Keypad	2-3
MODEM COMM	7-1, 10-4
Modems	7-1
Momentary Exit Type 29	4-7
Mounting The Control Cabinet	3-1
Multi-Access ?	9-3
Multi-Panel View Mode	2-7
Multi-Partition Multi-Panel Mode	2-6
Multiple Alarms	5-3
Multiple Partition Access	9-2

N

No Alarm Response Type 23	4-7
Normally Closed or EOLR (Zones 2-8)	5-4
Number of Partitions	5-11

O

OC or OPEN CIRCUIT	3-3
Off-Normal Report	10-4
On-Line Control Functions	7-3
Open/Close Reporting	9-2
Open/Close Reports by Exception	5-12, 6-3
Open/Close Schedule	6-3
Open/Close Schedule Programming	6-6
Open/Close Schedules	6-4, 6-5
Open/Close Windows	6-8
Operator Access Levels	7-1
Operator Codes Levels 3-5	9-1
Output Device Control Commands	B-1
Output Devices	3-17
OUTPUT PGM	4-3
Overvoltage Protection	3-7

P

PABX Access Code	5-3
Pager 1 Delay 1	5-13
Pager 1 Delay 2	5-13
Pager 1 Format	5-13
Pager 1 ID Number	5-13
Pager 1 Partition Enable	5-14
Pager 1 Phone Number	5-13
Pager 1 Trigger Event Enables	5-14, 5-17
Pager 2 Delay 1	5-14
Pager 2 Delay 2	5-14
Pager 2 Format	5-14
Pager 2 ID Number	5-14
Pager 2 Partition Enable	5-14
Pager 2 Phone Number	5-14
Pager 2 Trigger Event Enables	5-14
Pager 3 Delay 1	5-14
Pager 3 Delay 2	5-14
Pager 3 Format	5-14
Pager 3 ID Number	5-14
Pager 3 Partition Enable	5-14
Pager 3 Phone Number	5-14
Pager 3 Trigger Event Enables	5-15
Pager 4 Delay 1	5-15
Pager 4 Delay 2	5-15
Pager 4 Format	5-15
Pager 4 ID Number	5-15
Pager 4 Partition Enable	5-15
Pager 4 Phone Number	5-15
Pager 4 Trigger Event Enables	5-15
Pager 5 Delay 1	5-15
Pager 5 Delay 2	5-15
Pager 5 Format	5-15
Pager 5 ID Number	5-15
Pager 5 Partition Enable	5-15
Pager 5 Phone Number	5-15
Pager 5 Trigger Event Enables	5-15
Pager 6 Delay 1	5-16
Pager 6 Delay 2	5-16

Pager 6 Format 5-16
 Pager 6 ID Number 5-16
 Pager 6 Partition Enable..... 5-16
 Pager 6 Phone Number..... 5-16
 Pager 6 Trigger Event Enables 5-16
 Pager 7 Delay 1..... 5-16, 5-17, 5-18
 Pager 7 Delay 2..... 5-16, 5-17, 5-19
 Pager 7 Format 5-16, 5-17, 5-18
 Pager 7 ID Number 5-16, 5-17, 5-18
 Pager 7 Partition Enable..... 5-16, 5-17, 5-19
 Pager 7 Phone Number..... 5-16, 5-17, 5-18
 Pager 7 Trigger Event Enables 5-16, 5-17, 5-19
 Pager 8 Delay 1..... 5-17, 5-18
 Pager 8 Delay 2..... 5-17, 5-18
 Pager 8 Format 5-17, 5-18
 Pager 8 ID Number 5-16, 5-18
 Pager 8 Partition Enable..... 5-17, 5-18
 Pager 8 Phone Number..... 5-16, 5-17, 5-19
 Pager Format 3-23
 Pager Installed 5-13
 Paging Service 3-23
 Panel Link Module..... 2-4, 3-20
 Panel Link Module Supervision 2-5
 Panel Linking..... 2-4, 4-8
 Panel Linking Commands..... B-2
 panel linking users..... 2-5, 9-1
 Panic Button or Speedkey..... 5-9
 Partitioned System 2-1
 Partitioning 1-2, 2-1
 PassPoint Access Control (ACS) Type 10..... 4-8
 PassPoint Access Control System 3-26
 PassPoint Dialer Events 4-9
 Perimeter Type 03..... 4-6
 Peripherals Devices 1-2
 Permanent Keypad Display Backlighting..... 5-10
 Phone Module Access Code 5-2
 PLL out of Lock 3-22
 PLM 2-4
 polling loop 3-12
 Polling Loop Current Draw 3-32
 Polling Loop Supervision..... 3-13
 Power Failure 10-4
 Power Unattained..... 3-22
 Power-Up in Previous State 5-3
 Prevent Zone XXX Bypass 5-4
 Primary Format..... 5-5
 Primary Phone Number..... 5-4
 Primary Subscriber's Account Number..... 5-3
 Printer Baud Rate 5-11
 Printer Configurations..... 3-27
 Printer Type..... 5-11
 Priority of Displays for Panel Linking 2-7
 Program Modes..... 4-1
 Programming Commands..... B-1
 PROGRAMMING COMMANDS 4-1
 Programming Entry Errors..... 4-2
 Programming Overview 4-1
 Programming Partition-Specific Data Fields 4-2
 Programming Scheduling Options..... 6-4
 Programming System-Wide Data Fields..... 4-2

Q

Quick Arm..... 5-3, 9-1
 Quick Exit 5-1

R

Random time 6-8
 Randomize AC Loss Report..... 5-2
 RCVR SETUP ERROR 10-4
 Real-Time Clock..... 8-1
 Recent Close..... 1-2
 Refresh Feature 6-7
 Regulatory Agency Statements A-1
 Relay commands..... 6-8
 Relay Timeout XXX Minutes 5-11
 Relay Timeout YYY Seconds 5-11
 REPORT CODE PROG 4-3
 Reporting Formats..... 3-7
 Request to Exit (RTE) Type 12 4-8
 Restore Report Timing 5-7
 Restrict Disarming..... 6-1
 RF Motion..... 3-16
 RF Motion (RM) Type 02..... 4-7
 RF Receiver Supervision Check-in Interval..... 5-9
 RF System Installation Advisories..... 3-15
 RF System Operation and Supervision 3-14
 RF Transmitter Check-in Interval 5-9
 RF Transmitter Low Battery Reporting..... 5-9
 RF Transmitter Low Battery Sound 5-9
 Ring Count 7-2
 Ring Detection Count 5-5
 RINGER EQUIVALENCE..... C-1
 RJ31X 3-7
 RJ31X jack..... 3-28
 RLY VOICE DESCR..... 4-3
 RS-485 2-4
 RS-485 Bus 3-21
 RTE 4-8

S

Scheduled Check-in 7-3
 Scheduled Download 7-3
 Scheduling 6-1
 Scheduling Commands B-2
 Scheduling Menu Mode..... 6-4
 Scheduling Menu Structure 6-4
 Secondary Format..... 5-5
 Secondary Phone Number 5-4
 Secondary Subscriber Account Number 5-7
 Send Cancel If Alarm + Off..... 5-10
 Send Message to Pager After Dialer..... 5-13
 serial number devices 3-13
 Serial Number Polling Loop (DS) Type 08 4-8
 Serial Number Polling Loop (SL) Type 06 4-8
 SESCOA C-1
 SESCOA/Radionics..... 3-7
 SESCOA/Radionics Select..... 5-5
 Single-Partition Single-Panel Mode..... 2-5
 Smoke Detector Reset 3-20
 Specifications C-1
 Standard/Expanded Reporting Primary..... 5-5
 Standard/Expanded Reporting Secondary 5-5
 Standby Battery Size..... 3-33
 Supervised Fire (Without Verification) Type 09 4-7
 Supervised RF 3-16
 Supervised RF (RF) Type 03 4-8
 Supervision Pulses for LRR 5-13

Supervisory Messages	10-4
Supplementary Power Supply	3-3
Suppress Transmitter Supervision Sound	5-10
Swinger Suppression	5-6
System Commands	B-1
System Communication.....	1-3
System Events Notify	5-1
SYSTEM LO BAT	10-4
System LoBat"	10-1
System Messages	10-4
System Sensor A77-716B EOL Relay Module	3-9
System Sensor MA 12/24D	3-4
System Sensor P12575.....	3-4

T

Tamper Supervision	3-11
TAP protocol.....	3-23
Telephone Line Connections.....	3-7
TELEPHONE OPERATIONAL PROBLEMS	A-3
TeleSmart.....	4-8
Temporary Schedule	6-3
Temporary Schedules	6-12
Temporary Schedules Programming.....	6-13
Test Report Interval.....	5-3
Testing The System	10-1
Time Driven Events	6-2
Time Driven Events Worksheet.....	6-7
Time to Delay Pager After Dialer.....	5-13
Time Window Definitions.....	6-2
Time Windows.....	6-4, 6-5
Time Windows Programming	6-5
Timed Events	6-4
Time-Driven Event Programming	6-9
Time-Driven Events.....	6-7
Time-Driven Events Programming	6-7
TouchTone or Rotary Dial	5-3
TouchTone with Rotary Backup	5-9
Transformer Connections.....	3-30
Transmitter Battery Life	3-17
Transmitter ID Sniffer Mode	10-1
Transmitter Input Types.....	3-16
Transmitter Supervision.....	3-16
Trouble by Day/Alarm by Night Type 05.....	4-6
Trouble Conditions	10-4
Trouble Messages.....	10-4
Trouble/Supervisory Activation.....	3-6
Turning the System Over to the User	10-5

U

UL Installation Requirements	A-1
UL365 Police Station Connected Burglar Alarm.....	A-2
UL609 Grade A Local Mercantile Premises/Local Mercantile Safe & Vault.....	A-1
UL611/UL1610 Central Station Burglary Alarm	A-2
UL864/NFPA Central Station and Remote Station Fire.....	A-1
UL864/NFPA Local Fire.....	A-1
UNABLE TO ARM LOBBY PARTITION	2-2
Unattended Download.....	7-1

Unattended Mode.....	5-5
Unsupervised RF.....	3-16
Unsupervised RF (UR) Type 04	4-8
Use Partition Descriptor	5-12
User Access Codes.....	9-1
User Code Authority Levels.....	9-1
User Code Commands.....	B-1
user code defaults.....	9-1
User Code Rules.....	9-2
User Scheduling Menu Mode	6-13
Users.....	2-1
Using ACS Zone Inputs.....	4-9

V

VA8200	2-4, 3-20
VA8201	3-23
View Capabilities.....	9-1
VIP Module.....	3-27
VIP Module Phone Code.....	5-2
Vista Gateway Module	3-26
VISTA Gateway Module	4-9
VISTA-128B Plus as Stand-Alone Access Control	4-10
VISTA-128B PLUS Current Load	3-33
VistaKey	3-25, 4-9
VistaKey Dialer Enables.....	4-9

W

Wire Run Length	3-20
Wire Run Length/Gauge.....	3-3
Wireless Keypad Assignment.....	5-10
Wireless Keypad Tamper Detect.....	5-10
Wireless System Commands	B-1
Wireless Zone Expansion.....	3-14
Wiring Devices to Zones 1-9	3-8
Wiring the Alarm Output.....	3-4
Wiring the Keypads	3-3
Worksheets to calculate the total current	3-31
World Wide Web Address	10-5

Y

Yuasa	3-34
-------------	------

Z

Zone 5 Audio Alarm Verification	5-11
Zone 804	3-28
Zone Defaults.....	4-4
Zone Index	4-4
Zone Input Type Definitions	4-7
Zone Number Designations.....	4-4
ZONE PROG.....	vii, 4-3
Zone Response Type Definitions	4-6
Zone Type Restores for Zone Types 1-8.....	5-6
Zone Type Restores for Zone Types 9, 10 and 16.....	5-6
Zones	2-1

WARNING!

THE LIMITATIONS OF THIS ALARM SYSTEM

While this System is an advanced wireless security system, it does not offer guaranteed protection against burglary, fire or other emergency. Any alarm system, whether commercial or residential, is subject to compromise or failure to warn for a variety of reasons. For example:

- Intruders may gain access through unprotected openings or have the technical sophistication to bypass an alarm sensor or disconnect an alarm warning device.
- Intrusion detectors (e.g., passive infrared detectors), smoke detectors, and many other sensing devices will not work without power. Battery-operated devices will not work without batteries, with dead batteries, or if the batteries are not put in properly. Devices powered solely by AC will not work if their AC power supply is cut off for any reason, however briefly.
- Signals sent by wireless transmitters may be blocked or reflected by metal before they reach the alarm receiver. Even if the signal path has been recently checked during a weekly test, blockage can occur if a metal object is moved into the path.
- A user may not be able to reach a panic or emergency button quickly enough.
- While smoke detectors have played a key role in reducing residential fire deaths in the United States, they may not activate or provide early warning for a variety of reasons in as many as 35% of all fires, according to data published by the Federal Emergency Management Agency. Some of the reasons smoke detectors used in conjunction with this System may not work are as follows. Smoke detectors may have been improperly installed and positioned. Smoke detectors may not sense fires that start where smoke cannot reach the detectors, such as in chimneys, in walls, or roofs, or on the other side of closed doors. Smoke detectors also may not sense a fire on another level of a residence or building. A second floor detector, for example, may not sense a first floor or basement fire. Finally, smoke detectors have sensing limitations. No smoke detector can sense every kind of fire every time. In general, detectors may not always warn about fires caused by carelessness and safety hazards like smoking in bed, violent explosions, escaping gas, improper storage of flammable materials, overloaded electrical circuits, children playing with matches, or arson. Depending on the nature of the fire and/or location of the smoke detectors, the detector, even if it operates as anticipated, may not provide sufficient warning to allow all occupants to escape in time to prevent injury or death.
- Passive Infrared Motion Detectors can only detect intrusion within the designed ranges as diagrammed in their installation manual. Passive Infrared Detectors do not provide volumetric area protection. They do create multiple beams of protection, and intrusion can only be detected in unobstructed areas covered by those beams. They cannot detect motion or intrusion that takes place behind walls, ceilings, floors, closed doors, glass partitions, glass doors, or windows. Mechanical tampering, masking, painting or spraying of any material on the mirrors, windows or any part of the optical system can reduce their detection ability. Passive Infrared Detectors sense changes in temperature; however, as the ambient temperature of the protected area approaches the temperature range of 90° to 105°F (32° to 40°C), the detection performance can decrease.
- Alarm warning devices such as sirens, bells or horns may not alert people or wake up sleepers if they are located on the other side of closed or partly open doors. If warning devices are located on a different level of the residence from the bedrooms, then they are less likely to waken or alert people inside the bedrooms. Even persons who are awake may not hear the warning if the alarm is muffled by noise from a stereo, radio, air conditioner or other appliance, or by passing traffic. Finally, alarm warning devices, however loud, may not warn hearing-impaired people.
- Telephone lines needed to transmit alarm signals from a premises to a central monitoring station may be out of service or temporarily out of service. Telephone lines are also subject to compromise by sophisticated intruders.
- Even if the system responds to the emergency as intended, however, occupants may have insufficient time to protect themselves from the emergency situation. In the case of a monitored alarm system, authorities may not respond appropriately.
- This equipment, like other electrical devices, is subject to component failure. Even though this equipment is designed to last as long as 20 years, the electronic components could fail at any time.

The most common cause of an alarm system not functioning when an intrusion or fire occurs is inadequate maintenance. This alarm system should be tested weekly to make sure all sensors and transmitters are working properly. The security keypad (and remote keypad) should be tested as well.

Wireless transmitters (used in some systems) are designed to provide long battery life under normal operating conditions. Longevity of batteries may be as much as 4 to 7 years, depending on the environment, usage, and the specific wireless device being used. External factors such as humidity, high or low temperatures, as well as large swings in temperature, may all reduce the actual battery life in a given installation. This wireless system, however, can identify a true low battery situation, thus allowing time to arrange a change of battery to maintain protection for that given point within the system.

Installing an alarm system may make the owner eligible for a lower insurance rate, but an alarm system is not a substitute for insurance. Homeowners, property owners and renters should continue to act prudently in protecting themselves and continue to insure their lives and property. We continue to develop new and improved protection devices. Users of alarm systems owe it to themselves and their loved ones to learn about these developments.

LIMITED WARRANTY

Pittway Corporation, and its divisions, subsidiaries and affiliates ("Seller"), 165 Eileen Way, Syosset, New York 11791, warrants its First Alert products to be in conformance with its own plans and specifications and to be free from defects in materials and workmanship under normal use and service for 36 months from the date stamp control on the product or, for products not having a date stamp, for 30 months from date of original purchase unless the installation instructions or catalog sets forth a shorter period, in which case the shorter period shall apply. Seller's obligation shall be limited to repairing or replacing, at its option, free of charge for materials or labor, any product which is proved not in compliance with Seller's specifications or proves defective in materials or workmanship under normal use and service. Seller shall have no obligation under this Limited Warranty or otherwise if the product is altered or improperly repaired or serviced by anyone other than First Alert Professional factory service. For warranty service, return product transportation prepaid, to:

First Alert Professional Factory Service, 165 Eileen Way, Syosset, New York 11791.

THERE ARE NO WARRANTIES, EXPRESS OR IMPLIED, OF MERCHANTABILITY, OR FITNESS FOR A PARTICULAR PURPOSE OR OTHERWISE, WHICH EXTEND BEYOND THE DESCRIPTION ON THE FACE HEREOF. IN NO CASE SHALL SELLER BE LIABLE TO ANYONE FOR ANY CONSEQUENTIAL OR INCIDENTAL DAMAGES FOR BREACH OF THIS OR ANY OTHER WARRANTY, EXPRESS OR IMPLIED, OR UPON ANY OTHER BASIS OF LIABILITY WHATSOEVER, EVEN IF THE LOSS OR DAMAGE IS CAUSED BY THE SELLER'S OWN NEGLIGENCE OR FAULT.

Seller does not represent that the products it sells may not be compromised or circumvented; that the products will prevent any personal injury or property loss by burglary, robbery, fire or otherwise; or that the products will in all cases provide adequate warning or protection. Customer understands that a properly installed and maintained alarm may only reduce the risk of a burglary, robbery, fire or other events occurring without providing an alarm, but it is not insurance or a guarantee that such will not occur or that there will be no personal injury or property loss as a result. CONSEQUENTLY, SELLER SHALL HAVE NO LIABILITY FOR ANY PERSONAL INJURY, PROPERTY DAMAGE OR OTHER LOSS BASED ON A CLAIM THE PRODUCT FAILED TO GIVE WARNING. HOWEVER, IF SELLER IS HELD LIABLE, WHETHER DIRECTLY OR INDIRECTLY, FOR ANY LOSS OR DAMAGE ARISING UNDER THIS LIMITED WARRANTY OR OTHERWISE, REGARDLESS OF CAUSE OR ORIGIN, SELLER'S MAXIMUM LIABILITY SHALL NOT IN ANY CASE EXCEED THE PURCHASE PRICE OF THE PRODUCT, WHICH SHALL BE THE COMPLETE AND EXCLUSIVE REMEDY AGAINST SELLER. This warranty replaces any previous warranties and is the only warranty made by Seller on this product. No increase or alteration, written or verbal, of the obligations of this Limited Warranty is authorized.

NOTES

NOTES

NOTES

NOTES

NOTES

NOTES

NOTES

NOTES

TEST BURGLARY SYSTEM WEEKLY

TYPES OF FIRE SIGNALING SERVICE:

- Manual fire alarm, automatic fire alarm, sprinkler supervisory and waterflow alarm, UL Listed local control (non-coded).
- UL Listed central station and remote station protected premises unit when used with 5140DLM back-up dialer module. Installation limits under jurisdiction of local authority.

WARNING:
THIS UNIT MAY BE PROGRAMMED TO INCLUDE AN ALARM VERIFICATION FEATURE THAT WILL RESULT IN A DELAY OF THE SYSTEM ALARM SIGNAL FROM THE INDICATED FIRE CIRCUITS. THE TOTAL DELAY (CONTROL UNIT PLUS SMOKE DETECTORS) SHALL NOT EXCEED 60 SECONDS. NO OTHER INITIATING DEVICES SHALL BE CONNECTED TO THESE CIRCUITS UNLESS APPROVED BY THE LOCAL AUTHORITY HAVING JURISDICTION.

CIRCUIT CONTROL UNIT (ZONE)	SMOKE DETECTOR DELAY-SEC	MODEL	DELAY-SEC

THE DELAY TIME MARKED ON THE INSTALLED DETECTOR(S) IS TO BE USED

This equipment should be installed in accordance with the National Fire Protection Association's Standard 72 (National Fire Protection Assoc., Batterymarch Park, Quincy, MA. 02269). Printed information describing proper installation, operation and testing, maintenance and repair service is to be provided with this equipment.

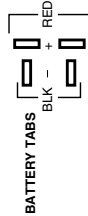

Connect to 12V, 12AH min/34.4AH max lead acid batteries using cables supplied. See instructions for correct polarity. Float charging voltage: 13.7VDC. Battery normally need not be replaced for at least 3 yrs.

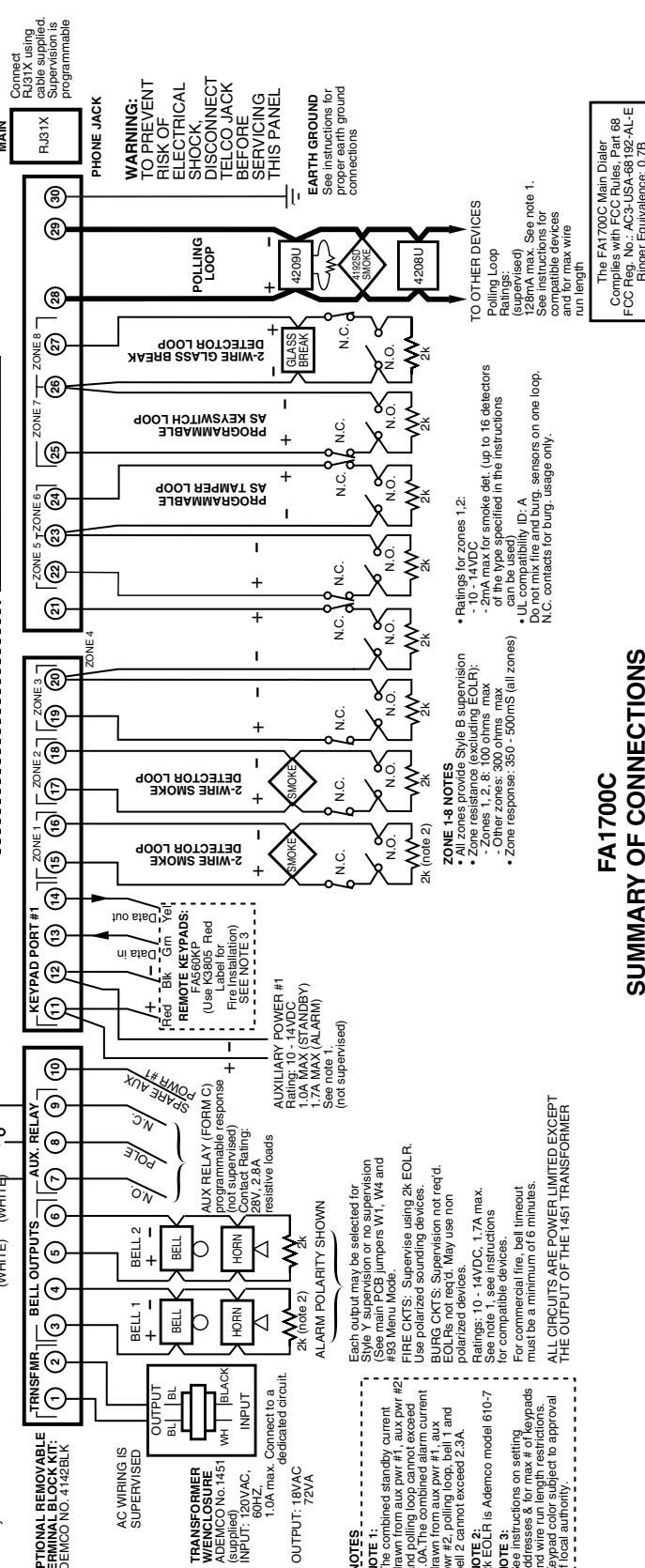
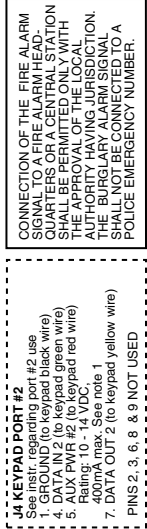
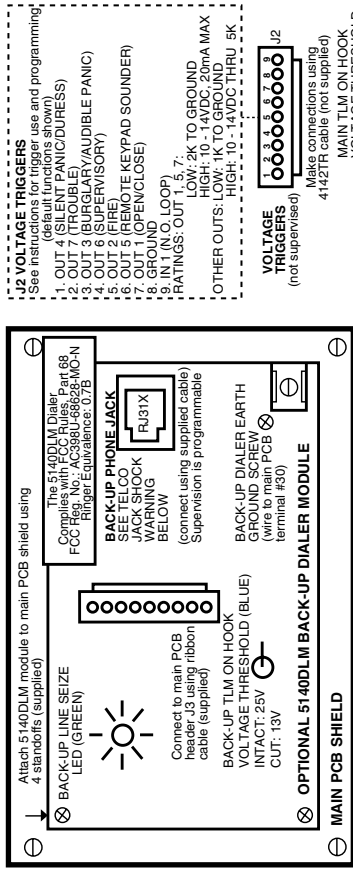



149 Eileen Way, Syosset, NY 11791

<http://firstalertpro.com>

Copyright © 2002 PITTMAY CORPORATION



K0376-1 8/02